

# Macro 4: Speed Programmed Winder (SPW)

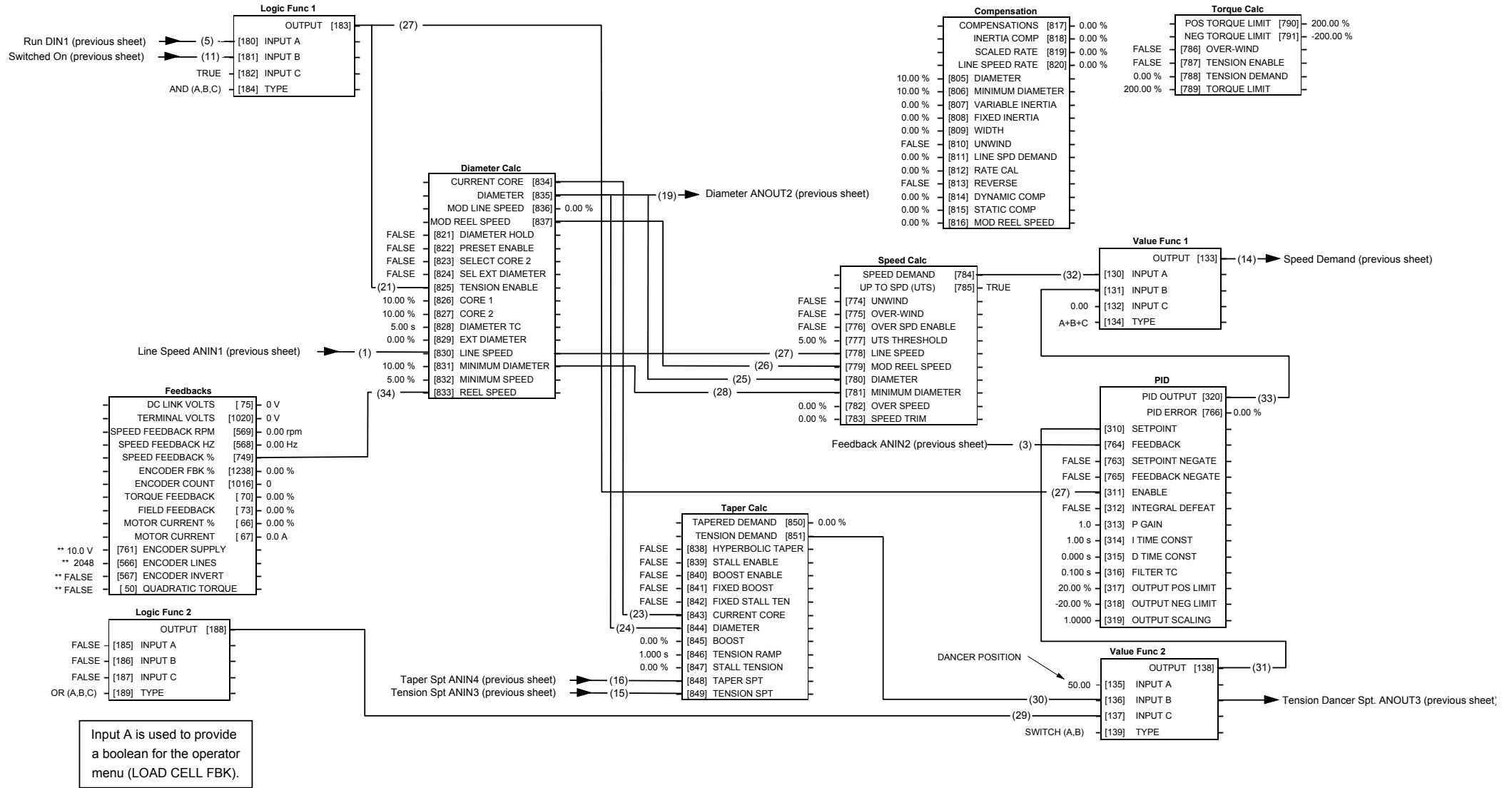

## Macro 4: Speed Programmed Winder (SPW)

### Macro 4: Speed Programmed Winder (SPW)

The winder macro is for tension control of closed loop winders. The function blocks control the motor speed with a closed loop trim to provide constant tension throughout the roll.

The basic tension control controls the motor speed, compensated for diameter, trimmed by a dancer position loop or a loadcell tension loop, to produce constant web tension.

Other features provide Taper Tension, Stall Tension, Tension Boost, and Inertia Compensation.

Additional Operator Menu display parameters.

Control Wiring I/O			
Terminal	Name	Purpose	Comment
2	ANALOG INPUT 1	Line Speed	-10V = -100%, 10V = 100%
3	ANALOG INPUT 2	Feedback	-10V = -100%, 10V = 100%
4	ANALOG INPUT 3	Tension Setpoint	0V = 0%, 10V = 100%
5	ANALOG INPUT 4	Taper Setpoint	0V = 0%, 10V = 100%
6	ANALOG OUTPUT 1	Speed Demand	absolute speed demand 0V = 0%, 10V = 100%
7	ANALOG OUTPUT 2	Diameter	diameter 0V = 0%, 10V = 100%
8	ANALOG OUTPUT 3	Tension/Dancer Setpoint	tension diagnostic in load cell mode, or load setpoint for dancer -10V = -100%, 10V = 100%
12	DIGITAL INPUT 1	Run Forward	24V = run forward
13	DIGITAL INPUT 2	Run Reverse	24V = run reverse
14	DIGITAL INPUT 3	Not Stop	24V = RUN FWD and RUN REV signals latched 0V = RUN FWD and RUN REV signals not latched
15	DIGITAL INPUT 4	Remote Reverse	0V = remote forward 24V = remote reverse
16	DIGITAL INPUT 5	Jog	24V = jog
17	DIGITAL INPUT 6	Drive Enable	24V = drive enable
18	DIGITAL INPUT 7	Fast Stop	0V = fast stop
19	DIGITAL INPUT 8	External Trip	Non-configurable 0V = Trip (connect to terminal 20)
21, 22	DIGITAL OUTPUT 1	Health	0V = tripped, i.e. not healthy
23, 24	DIGITAL OUTPUT 2	Running	0V = stopped, 24V = running
25, 26	DIGITAL OUTPUT 3	Switched On	0V = not ready, 24V = switched on

### The Operator Menu for Macro 4

The default Operator Menu is shown below.

