

AX 345 and AX 347

Process Indicators with Two Analogue Inputs and Calculations



AX 345	Process Indicator, Display only
AX 346:	Process Indicator with Analogue Outputs 0 - 10 V und 0/4 – 20 mA (separate manual available)
AX 347:	Process Indicator with 2 Presets and Optocoupler Outputs

- Two analogue inputs with independent scaling, each +/- 10V or 0/4 – 20 mA
- Operating modes for display of input A, input B as well as combinations A + B, A - B, A x B und A : B
- Fully programmable scaling and zero definitions
- Useful supplementary functions like Tare function, programmable averaging functions, programmable linearization etc.
- Power supply 115/230 VAC and 17-30 VDC in the same unit
- Aux. output 24 VDC / 100 mA for sensor supply

Operating Instructions



Safety Instructions

- This manual is an essential part of the unit and contains important hints about function, correct handling and commissioning. Non-observance can result in damage to the unit or the machine or even in injury to persons using the equipment!
- The unit must only be installed, connected and activated by a qualified electrician
- It is a must to observe all general and also all country-specific and application-specific safety standards
- When this unit is used with applications where failure or mal-operation could cause damage to a machine or hazard to the operating staff, it is indispensable to meet effective precautions in order to avoid such consequences
- Regarding installation, wiring, environmental conditions, screening of cables and earthing, you must follow the general standards of industrial automation industry
- - Errors and omissions excepted –

Version:	Description:
A04/2007	First edition
AX34507b_hk/kk/10/2007	Add new key CMD commands

Table of Contents

1.	Introduction	4
2.	Terminal Assignments	5
2.1.	Power supply	5
2.2.	Aux. voltage output	6
2.3.	Analogue inputs	6
2.4.	Optocoupler (transistor) outputs (model AX 347 only)	6
3.	Jumper settings	7
4.	How to Operate the Keys	9
4.1.	Normal display state	9
4.2.	Parameter settings	10
4.2.1.	How to select a parameter	10
4.2.2.	How to change parameter settings	10
4.2.3.	How to store settings	10
4.2.4.	Time-out function	10
4.3.	Teach operation	11
4.4.	Set all parameters to "Default"	11
5.	The Parameter Menu	12
6.	Setup Procedure	13
6.1.	Basic Parameters	13
6.2.	Operational parameters	14
6.3.	Keypad locking	14
6.4.	Modes of operation	15
6.4.1.	Single mode (input A only)	15
6.4.2.	Dual Mode (Inputs A and B separately)	16
6.4.3.	Combined Modes (A+B, A-B, A:B, A•B)	17
6.4.4.	Additional settings for use of the Preselections (models AX 347)	18
7.	Commissioning	21
8.	Special Functions	22
8.1.	Tare / Offset function	22
8.2.	Linearization	22
8.3.	Manual input or „Teaching“ of the interpolation points	24
8.4.	Update time of the display and response time of outputs	25
9.	Technical Specifications	26
9.1.	Dimensions	26
9.2.	Technical data	27
9.3.	Commissioning Form	28

1. Introduction

Some of the general demands to an up-to-date process controller for automation industry are always high flexibility, combined with easy and simple operability.

Many applications require two separate analogue inputs for use with single or combined operation.

Also it may be important to display and evaluate both, linear and non-linear analogue inputs at an acceptable accuracy, which requires programmable linearization functions.

Process controllers of series AX 345 - 347 have been designed for this kind of requirements.

Model **AX 345** provides **display** function only.

Model **AX 346** provides additional **analogue outputs** instead of the Preselections

Model **AX347** provides two additional programmable **Preselections** with Optocoupler outputs

All other functions within this controller family are fully similar.



The present operating instructions are valid for models AX 345 and AX347 only.
Separate operating instructions are available for model AX 346

2. Terminal Assignments

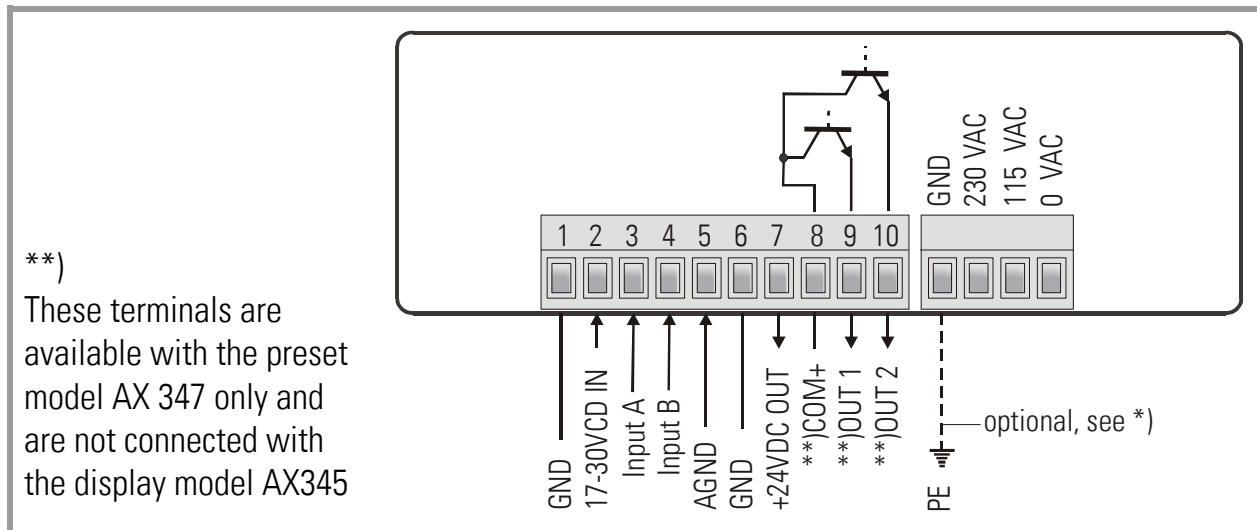

- *) The connection of PE is optional and not necessary for safety or for EMC. However, with some applications, it can be useful to ground the common potential of all signal lines



- When using this earthing option, please be aware that all terminals marked GND or AGND will be earthed.
- Multiple earthing on different positions of an installation may cause problems, especially with poor overall performance of the whole earthing and screening system!
- The minus potential of analogue inputs is internally connected to the minus of the DC supply. When you like to use current loops through several units, it is therefore necessary to supply the units from either AC power or from several, potential-separated DC sources.

2.1. Power supply

The unit accepts DC supply from 17V to 30V when using terminals 1 and 2, and the consumption depends on the level of the supply voltage (typical 80 mA at 30V or 130mA at 17V, plus current taken from the aux. output).

For AC supply, terminals 0 VAC and 115 VAC or 230 VAC can be used. The total AC power is approximately 7.5 VA.

2.2. Aux. voltage output

Terminal 7 provides an auxiliary output of 24 VDC / 150 mA max. for supply of sensors and encoders. This is valid for AC supply and DC supply of the unit as well.

2.3. Analogue inputs

There are two analogue inputs with common minus potential available (Input A and Input B). Both refer to the AGND potential of terminal 5 which is internally connected to terminals 1, 6 and GND.

The analogue inputs can be configured for voltage input (+/- 10 V) or current input (0/4 – 20 mA), by means of internal jumpers (see 2.)



Ex factory, both inputs are always configured for current input.
(see section 3 for jumper settings)

2.4. Optocoupler (transistor) outputs (model AX 347 only)

The outputs provide programmable switching characteristics and are potential-free. Please connect terminal 8 (COM+) to the positive potential of the voltage you like to switch (range 5V....35V).

You must not exceed the maximum output current of 150mA. Where you intend to switch inductive loads, please provide filtering of the coil by means of external diodes.

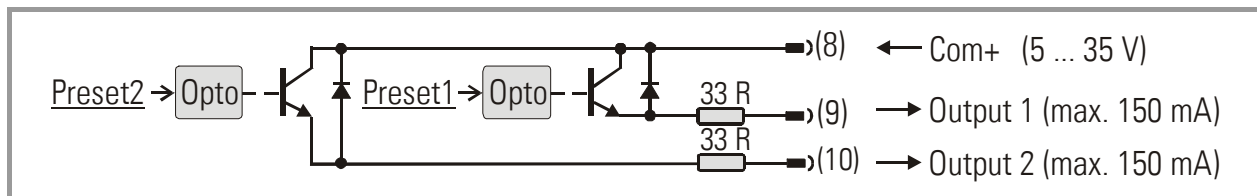

3. Jumper settings

When your input signal is a current of 0-20 mA or 4-20 mA, there is no need to change jumper settings and you can skip this section.

Where, however, you intend to use one or both inputs for voltage signals, you must change the internal jumper settings correspondingly. To access the jumpers, you must remove the screw terminal connectors and the backplane. Then pull the print to the rear to see the jumpers.



Wrong jumper settings may cause serious damage to the unit!

To access the jumpers, you have to disconnect the rear screw terminal strips, remove the back plane from the unit and pull the PCB out of the housing



Removal of the back plane

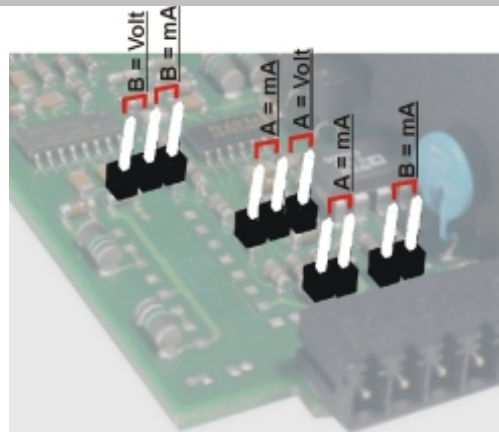

Location and function of the jumpers

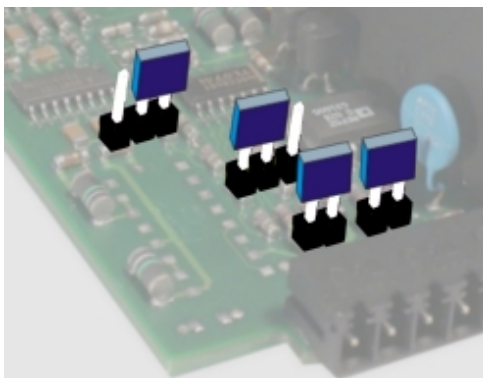

Factory setting:
Input A = current, input B = current

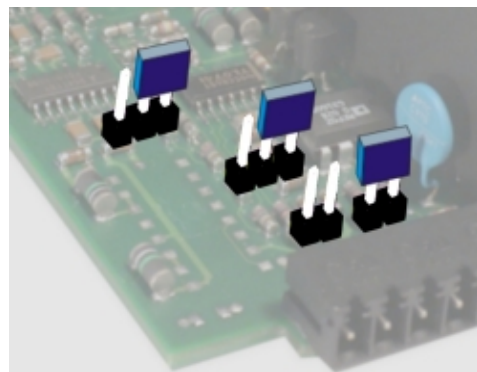

Input A = voltage, input B = current

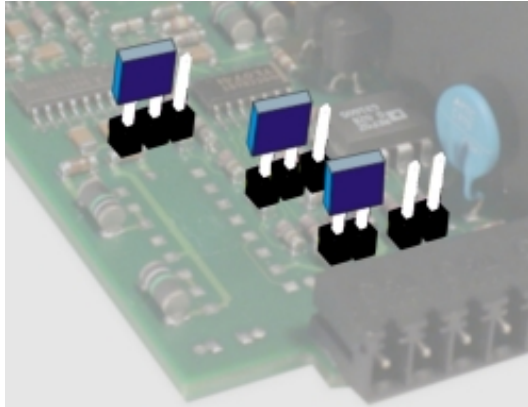

Input A = current, input B = voltage

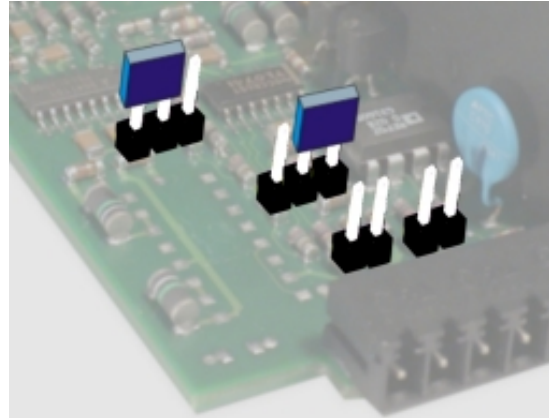

Input A = voltage, input B = voltage

After setting the jumpers, please shift the print carefully back to the housing, in order not to damage the front pins for connection to the keypad plate.



Current inputs are automatically scaled to an input range of 0/4 – 20 mA.
Voltage inputs use the standard range of +/- 10V.

You are free to measure voltages up to 120 volts DC by use of a remote resistance in series to the input line (please observe applicable safety standards!). You can calculate the value from the formula

$$R \text{ [k}\Omega\text{]} = 3 \times V \text{ [volts]} - 30$$

R = resistance value

V = input voltage

Example: Desired input = 100 volts:
 $R = 300 - 30 \text{ (k}\Omega\text{)} = 270 \text{ k}\Omega$

With regard to the scaling procedure described later, the new maximum input with resistance will work like a 10 volts signal with no resistance

4. How to Operate the Keys

The unit uses 3 front keys for all setup operations. Subsequently, the key functions will be named as shown in the table below.

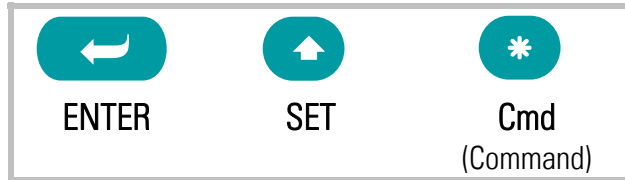

The functions of the keys are depending on the actual operating state of the unit.

The following three operating states apply:

- Normal display state
- Setup state
 - a.) Basic setup
 - b.) Operational parameter setup
- Teach operation

4.1. Normal display state



You can only change over to the other states while the unit is in the normal display state.

Change over to	Key operation
Basic setup	Keep ENTER and SET down simultaneously for 3 seconds
Operational parameter setup	Keep ENTER down for 3 seconds.
Teach operation	Keep SET down for 3 seconds

The Cmd key is only used with the Tare and Reset function and for the Teach procedure during linearization (see section 8).

4.2. Parameter settings

4.2.1. How to select a parameter

The ENTER key will scroll through the menu. The SET key allows to select the corresponding item and to change the setting or the numeric value. After this, the selection can be stored by ENTER again, which automatically changes over to the next menu item.

4.2.2. How to change parameter settings

With numerical entries, at first the lowest digit will blink. When keeping the SET key down, the highlighted digit will scroll in a continuous loop from 0 ... 9 ... 0 ... 9. When you release the SET key, the actual digit will remain and the next digit will be highlighted (blink).

This procedure allows setting all digits to the desired values. After the most significant digit has been set, the low order digit will blink again and you can do corrections if necessary.

With signed parameters, the high order digit will only scroll between the values "0" (positive) and "-" (negative)

4.2.3. How to store settings

To store the actual setting, press the ENTER key, which will also automatically scroll forward the menu.

The unit changes from programming mode to normal operation when you keep down the ENTER key again for at least 3 seconds.

4.2.4. Time-out function

The "time-out" function will automatically conclude every menu level, when for a break period of 10 seconds no key has been touched. In this case, any entry which has not been confirmed by ENTER yet would remain unconsidered.

4.3. Teach operation



The Time-out function will be switched off during all Teach operations

Key	Function
	ENTER will conclude or abort any Teach operation in progress
	SET function is fully similar to normal set-up operation
	Cmd will store the display value to the register and will change over to the next interpolation point.

For details of the Teach procedure see section 8.3.

4.4. Set all parameters to “Default”

At any time you can return all settings to the factory default values.

The factory default settings are shown in the parameter listings in section 6.



When you decide to set all parameters to „default“, please be aware that all previous settings will be lost and you will need to do the whole set-up procedure once more

To execute the „Default“ setting function:

- Power the unit down.
- Press the ENTER key.
- Power the unit up again while the ENTER key is kept down

5. The Parameter Menu

The menu provides one section with "basic parameters" and another section with "operational parameters". On the display you will only find those parameters which have been enabled by the basic settings. E.g. when the Linearization Functions have been disabled in the basic set-up, the associated linearization parameters will also not appear in the parameter menu.

All parameters, as good as possible, are designated by text fragments. Even though the possibilities of forming texts are very limited with a 7-segment display, this method has proved to be most suitable for simplification of the programming procedure.

The subsequent table is to show the general structure of the whole menu only. Detailed descriptions of all parameters will follow in section 6.

Menu overview:

Basic Parameters
„n)odE"
„briGht"
"UPdAt"
„CodE "
„LinEAR"
"Crnd"
„CHAR 1" (AX347 only)
„CHAR 2" (AX347 only)
„HYSt 1" (AX347 only)
„HYSt 2" (AX347 only)

*) appears only when Tare function is-enabled

**) appears only when linearisation is enabled

Operational Parameters		
Single Mode	Dual Mode	Combined Modes
„PrES 1" (AX347 only)		
„PrES 2" (AX347 only)		
„inPutA"	„inPutA"	„inPutA"
„StArtA"	„StArtA"	„StArtA"
„End A"	„End A"	„End A"
„dPoi A"	„dPoi A"	„dPoi A"
„FiLt A"	„FiLt A"	„FiLt A"
"OFFS A" *)	"OFFS A" *)	
	„inPutb"	„inPutb"
	„StArtb"	„StArtb"
	„End b"	„End b"
	„dPoi b"	„dPoi b"
	„FiLt b"	„FiLt b"
	OFFS b" *)	
		„n) FAc"
		„d FAc"
		„P FAc"
		„dPoint"
	"P01_H " **)	
	"P01_Y " **)	
	---->	
	"P16_H " **)	
	"P16_Y " **)	

6. Setup Procedure

6.1. Basic Parameters

In general, the parameters described subsequently must be set with the very first commissioning of the unit only. For best comprehensibility, this section describes setup of all display functions only as needed for model AX 345, and settings applicable to preselections and switching outputs of AX 347 are described separately.

Menu Text		Default
Mode of operation	Mode of operation SINGLE Single input operation (input A only) DUAL Dual input operation (input A and input B separately) A + b Sum operation (input A + input B) A - b Differential operation (input A – input B) A ÷ b Dividing operation (ratio A : B) A × b Multiplying operation (product A x B)	SINGLE
Brightness of the display	Brightness of the display „ 100“ 100% of maximum brightness „ 80“ 80% of maximum brightness „ 60“ 60% of maximum brightness „ 40“ 60% of maximum brightness „ 20“ 20% of maximum brightness	„100“
Update time of the display	Update time of the display Updates the display every x.xxx seconds. Setting range from 0.050 to 9.999 seconds.	„0.300“
Keypad interlock code	Keypad interlock code no Keypad enabled continuously ALL Keypad locked for any access P_FREE Keypad locked, except for access to preselections Pres 1 und Pres 2	no
Mode of linearisation	Mode of linearisation no No linearization. The corresponding parameters will not appear in the menu. 1-9UR Linearization for the numeric range 0 – 99999. Interpolation points to be set in the positive range only (negative values will appear as a mirror). 4-9UR Linearization over the full range –99999 to +99999	no

Menu Text		Default
Cmd	Command key enable	off
	off The Command key is switched off and no Offset values will appear in the menu	
	offset The Cmd key will execute the Tare/Offset function	
	teach The Cmd key will execute the Teach function	
	both The Cmd key will execute both, the Tare and the Teach function	

6.2. Operational parameters

After the basic setup, you can access the operational parameters by pressing ENTER for at least 3 seconds. You will only find those parameter texts that are relevant for your mode of operation.

To exit the menu, keep again ENTER down for at least 3 seconds, or just wait for the automatic Time-Out function.

6.3. Keypad locking

When the code locking of the keypad has been switched on, any key access first results in display of



To access the settings, within the next 10 seconds you have to press the key sequence



or the unit will automatically return to the normal display mode

6.4. Modes of operation

6.4.1. Single mode (input A only)

Menu Text	Setting Range	Default
Input A <u>Input A range</u> Set the desired range for input A <input type="checkbox"/> in U Voltage +/-10V <input checked="" type="checkbox"/> in ,0 Current 0-20 mA <input type="checkbox"/> in ,4 Current 4-20 mA		<input type="text" value="in ,0"/>
Start A <u>Start value</u> Value which the unit will display with a zero input signal of 0 volts or 0/4 mA	-99999 ... 99999	0
End A <u>End value</u> Value which the unit will display with a full scale input of 10 volts or 20 mA	-99999 ... 99999	1000
dPo, A <u>Decimal point for signal A</u> Select the desired position of the decimal point 000000 No decimal point 00000.0 one decimal position ----> 0.00000 five decimal positions		00000.0
Filter A <u>Average filter input A</u> Adjustable floating average filter for smoothing the display with unsteady input signals <input type="checkbox"/> oFF No filtering 2,4,8,16 Number of floating averaging cycles		2
OFFSA <u>Offset value for input A *)</u> Offset value for the zero displacement of input A signals	-99999 ... 99999	0
*) When Tare function is switched on only		

6.4.2. Dual Mode (Inputs A and B separately)



With this mode, the SET key selects between display of channel A and display of channel B, and the bar of the high order LED indicates which of the two channels is actually in display.

Menu Text		Input Range	Default
Input b	<p>Input B range Set the desired range for input B</p> <p>in U Voltage +/-10V</p> <p>in .0 Current 0-20 mA</p> <p>in .4 Current 4-20 mA</p>		in .0
Start b	<p>Start value Value which the unit will display with a zero input signal of 0 volts or 0/4 mA</p>	-99999 ... 99999	0
End b	<p>End value Value which the unit will display with a full scale input of 10 volts or 20 mA</p>	-99999 ... 99999	1000
dPo. b	<p>Decimal point for signal B Select the desired position of the decimal point</p> <p>000000 No decimal point</p> <p>00000.0 one decimal position</p> <p>----></p> <p>0.00000 five decimal positions</p>		000000
Filter b	<p>Average filter input B Adjustable floating average filter for smoothing the display with unsteady input signals</p> <p>off No filtering</p> <p>2,4,8,16 Number of floating averaging cycles</p>		off
OFFSB	<p>Offset value for input B *) Offset value for the zero displacement of input A signals</p>	-99999 ... 99999	0
*) When Tare function is switched on only			

6.4.3. Combined Modes (A+B, A-B, A:B, A•B)

These modes allow displaying either the single channels A and B or the calculated result according to the selected combination. The SET key allows scrolling between the three displays.

A →  The upper bar of the high order digit indicates that you display channel A.

B →  The lower bar of the high order digit indicates channel B.

<AB>  When no bar is lit, the display shows the result of the calculation, according to the combination set.

When you use one of the combined modes, you will first have to do the same settings as with the "Dual" mode for individual display of inputs A and B.

The combined display will then be the result calculated from both single values.

The following additional parameters provide a final scaling facility, so you can read out the result of your combination in proper engineering units:

Menu Text	Setting Range	Default
nn FAc <u>Proportional Scaling Factor</u> Multiplies the result by this setting	-10000 ... 10000	1000
d FAc <u>Reciprocal Factor</u> Divides the result by this setting	1 ... 99999	1000
P FAc <u>Additive Constant</u> Adds or subtracts this setting	-99999 ... 99999	0
dPo, nt <u>Decimal Point</u> Sets the decimal point for the combined display value 000000 No decimal point 00000.0 one decimal position ----> 0.00000 five decimal positions		000000

Calculation Formula:

$$\boxed{\text{Final display value}} = \boxed{\text{value calculated from <AB>}} \times \boxed{\frac{m_Fac}{d_Fac}} \pm \boxed{P_Fac}$$

6.4.4. Additional settings for use of the Preselections (models AX 347)

Basic settings for Presets:

The basic setup menu provides the following additional parameters which are relevant for the operation of the presets and outputs only:

Menu Text		Setting Range	Default
CHAR 1	Output 1 switching characteristics		_J_ GE
	J GE Greater/Equal: Output is statically active with display greater or equal Preset.		
	J LE Lower/Equal: Output is statically active with display lower or equal Preset.		
	n GE Greater/Equal: Output is dynamically active with display greater or equal Preset. (timed output impulse)		
	n LE Lower/Equal: Output is dynamically active with display lower or equal Preset. (timed output impulse)		
CHAR 2	Output 2 switching characteristics		_J_ GE
	J GE See above		
	J LE See above		
	n GE See above		
	n LE See above		
	J 1-2 Output is statically active when the display reaches the value of Preset 1 – Preset 2 *)		
	n 1-2 Output is dynamically active when the display reaches the value of Preset 1 – Preset 2 *)		
HYS1	Switching Hysteresis 1 Programmable Hysteresis for output 1	0 ... 99999	0
HYS2	Switching Hysteresis 2 Programmable Hysteresis for output 2	0 ... 99999	0
*) Serves to generate an anticipation signal at a fixed distance to the preset 1 signal. The anticipation automatically follows the setting of preset 1.			

The direction of operation of the Hysteresis setting depends on the selected switching characteristics „GE“ or „LE“.

See adjoining figure

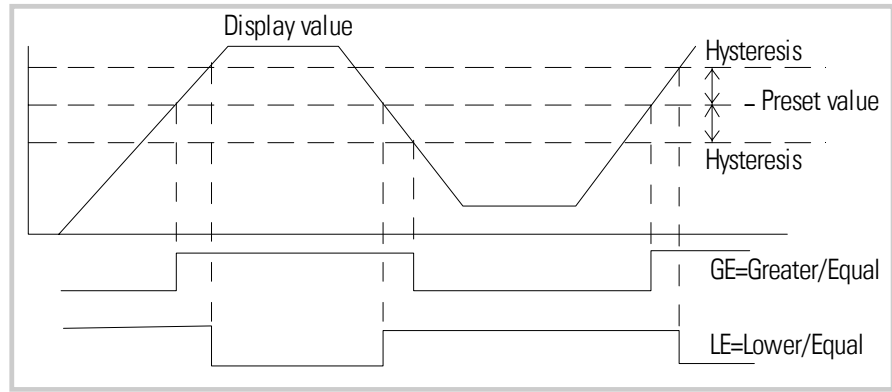

Where the switching outputs have been set to dynamic operation, the output impulse time is always 300 msec. (fixed time, only factory adjustable)

Operational settings for presets:

The settings for the Preselection values appear at the beginning of the operational parameters:

Menu Text	Setting Range	Default
PrES.1 Preselection 1	-99999 ... 99999	10000
PrES.2 Preselection 2	-99999 ... 99999	5000

Actual switching state of the outputs:

At any time you can find out the actual switching state of the outputs. For this, just push the ENTER key shortly during normal operation. The display will then provide one of the following information for the next two seconds:

Display	Meaning
1.2oFF	Both outputs are OFF (output transistors in high impedance state)
1.2oN	Both outputs are ON (output transistors in low impedance state))
1 on	Output 1 is ON Output 2 is OFF
2oN	Output 1 is OFF Output 2 is ON



- With all applications using “Single Mode” (6.4.1) or one of the “Combined Modes” (6.4.3), both presets always refer to the actual value appearing in display. Please be aware that toggling the display will affect the outputs
- Use of “Dual Mode” (6.4.2) automatically attaches Preset 1 to input channel A and Preset 2 to input channel B, independent on which of the values is actually in display
- When Preset 1 is used to monitor a minimum value with setting “LE”, and Preset 2 is used to monitor a maximum value with setting “GE”, then output 1 will operate with an **Automatic Startup-Inhibit**, i.e. it will become enabled only after the measuring value has crossed the minimum setting the first time.
Where **no startup-Inhibit** is desired, please use Preset 1 for Maximum and Preset 2 for minimum control.

7. Commissioning

Commissioning of this unit is easy and uncomplicated when following the subsequent steps:

	Step	Action	See section
1	Analogue inputs	<ul style="list-style-type: none">• Set jumpers	3
2	Basic settings	<ul style="list-style-type: none">• Select Operation mode• Keep linearization and Tare function off firstly	6.1 6.1
3	Parameter settings	<ul style="list-style-type: none">• Configuration of the analogue inputs, scaling of the display• If applicable, select combination and final scaling• Configuration of switching outputs (if applicable)	6.4 6.4.3 6.4.4
4	Supplementary functions	<ul style="list-style-type: none">• Set Tare function and Linearization (if applicable)	8

A Set-Up Form is available in the appendix of this manual, which may be used for a most convenient and clearly arranged setup procedure.

It is advisable to do settings for Tare and linearization functions quite at the end, after all other functions have already proved to work fine.

8. Special Functions

8.1. Tare / Offset function

This function will become active after the "Cmd" parameter has been set to "oFFSEt" or to "both"(see 6.1). As a result, every touch of the "Cmd" key will store the actual display value to the Offset register, resulting in a Zero display with the actual input signal.

8.2. Linearization

This function allows converting non-linear input signals into a linear presentation or vice-versa. There are 16 interpolation points available, which can be freely arranged over the whole measuring range in any distance. Between two points the unit automatically will interpolate straight lines.

For this reason it is advisable to set many points into areas with strong bending, and to use only a few points in areas with little bending. „Linearization Mode“ has to be set to either „1-quA“ or „4-quA“ to enable the linearization function (see subsequent drawing). This will change the linear measuring results into a non-linear display.

Parameters P01_x to P16_x select 16 x- coordinates, representing the display values which the unit would normally show in the display. With parameters P01_y to P16_y you can specify now, which values you would like to display instead of the corresponding _x values.

This means e.g. that the unit will replace the previous P02_x value by the new P02_y value.



- With respect to the consistency of the linearization, the x- registers have to use continuously increasing values, e.g. the x- registers must conform to the **constraint** $P01_X < P02_X < \dots < P15_X < P16_X$.
- Independent of the selected linearization mode, the possible setting range of all registers P01_x, P01_y, ..., P16_x, P16_y is always -99999 ... 99999.
- For measuring values lower than P01_x, the linearization result will always be P01_y.
- For measuring values higher than P16_x, the linearization result will always be P16_y.
- With operation modes "Single" and "Dual", all linearization refers to input channel A only. With all combined operation modes, linearization refers to the calculated final result of the selected combination.

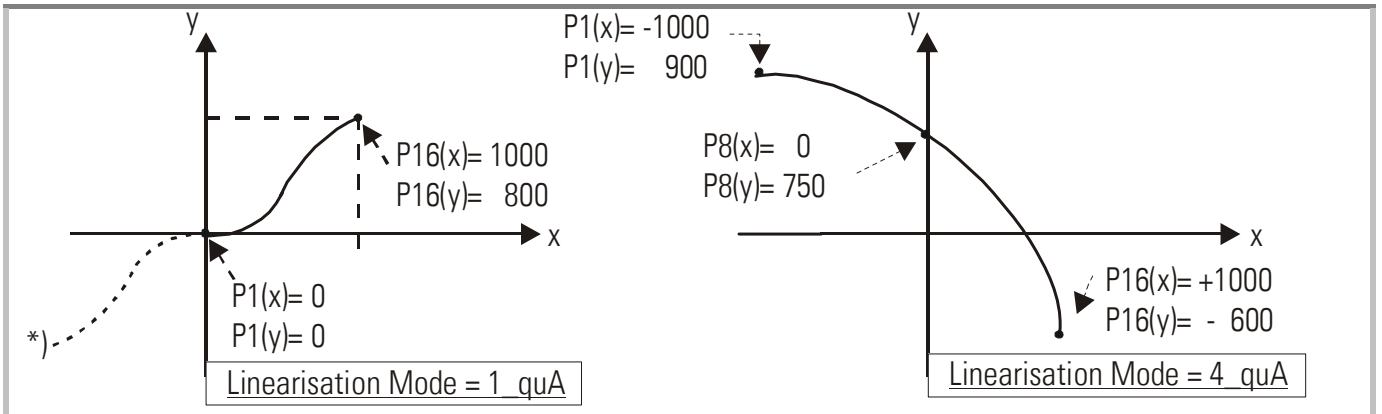

Application Example:

We like to display the filling quantity (volume) of a tank as shown below, with use of a pressure sensor mounted to the bottom of the tank. With this application the analogue pressure signal is proportional to the filling level, but not to the filling quantity.

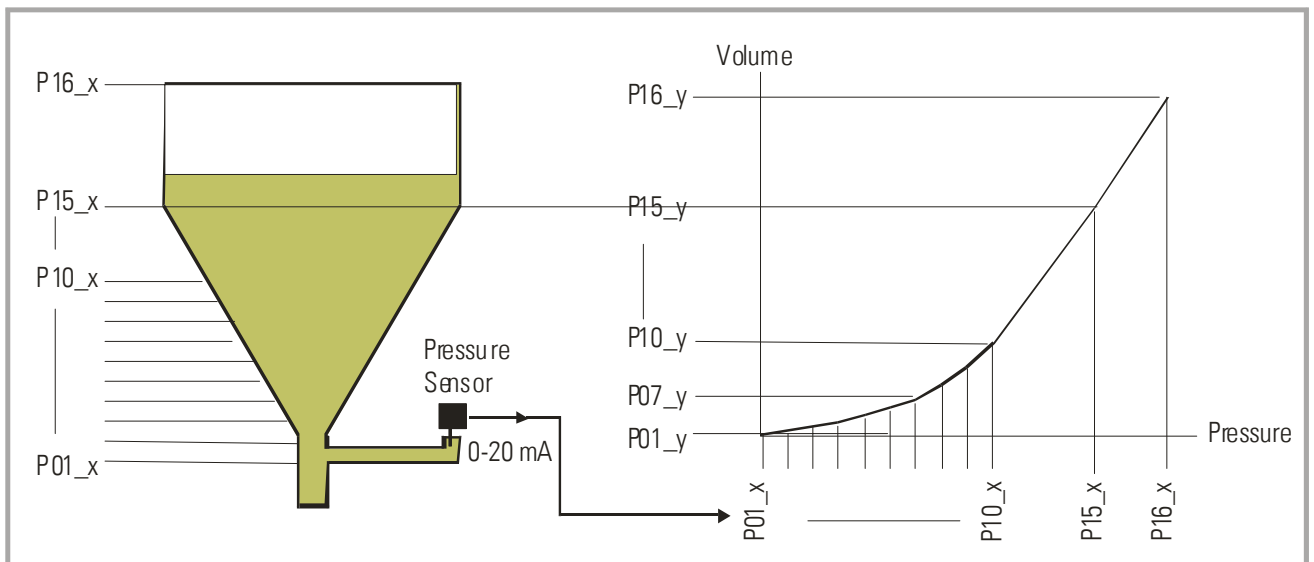

To solve the problem, we divide the non-linear part of the tank into 14 parts. We enter the expected display values of the pressure sensor to registers P01_x to P15_x. For the linear part of the tank it is sufficient to store the final pressure value to register P16_x. Now we can easily calculate the appropriate filling quantities and enter these values to the registers P01_y to P16_y.

8.3. Manual input or „Teaching“ of the interpolation points

Interpolation points to form the linearization curve can be entered one after another, using the same procedure as for all other numeric parameters. This means you will enter all parameters P01_x to P16_x and P01_y to P16_y manually by keypad.



During manual input of interpolation points the unit will not examine the settings P01_x to P16_x. Therefore the operator is responsible to observe the constraint $P01_X < P02_X < \dots < P15_X < P16_X$.

In many cases it should however be more convenient to use the Teach function. Here you have to sequentially apply all the x-values to the analogue input, and just add the corresponding y-values by keypad.

Preparation for teaching:

- Please select the desired range of linearization (see section 6.1).
- Please set the basic parameter „Cmd“ to „tEACH“ or „both“ (see section 6.1). After this, the teach function is ready to start.

How to use the Teach Function:

- Hold down the „Cmd“ key for 3 seconds, until the display shows „tEACH“. Now you are in the Teach mode.

To exit the teach mode again, you have the following two possibilities:

1. Press the enter key for 2 seconds. On the display you will read „StOP“ for a short time, and then the unit will switch back to the normal mode.
2. Just do nothing. After 10 seconds the unit will switch back to the normal mode automatically. In both cases the parameters of linearization P01_X to P16_Y will not change.

- To start the teach procedure please press „Cmd“ within the next 10 seconds. The display will show „P01_X“.



With respect to the consistency of the linearization, **ALL** parameters from P01_X to P16_Y will be overwritten by suitable initial values. Initial values for „P01_X“ and „P01_Y“ are -99999. All other values will start with 99999.

- Press once more "Cmd" to display the actual analogue input signal. Now arrange for the desired analogue input signal of the first interpolation point (with combined modes please arrange for both analogue signals)
- When you read the x-value of your first interpolation point in the display, press "Cmd" again. This will automatically store the actual display value to the P01_x register, and for about 1 second you will read "P01_y " on the display, followed again by the same reading stored previously.
- This display value now can be edited to the desired P01_y value, like a regular parameter
- When you read the desired P01_y value in your display, store it by pressing "Cmd" again. This will automatically cycle the display to the next interpolation point P02_x.



The unit will examine the constraint valid for the x-values of interpolation points.

Every interpolation point must be higher than its preceding point.

Where this constraint is breached, all 6 decimal points will blink automatically as a warning. Pressing the CMD key will not store the illegal value, but result in an error text "E.r.r.-L.O." as a warning.

- Once you have reached and stored the last interpolation points P16_x/y, the routine will restart with P01_x again, and you are free to double-check your settings once more.
- To conclude the Teach procedure, press the ENTER key. As a result you will read "StOP" for about 2 seconds, before the unit returns to the normal operation. All linearization points will at the same time be finally stored.

8.4. Update time of the display and response time of outputs

Parameter "UPdAt" allows setting a variable update time for the display (see section 6.1).



The response time of the optocoupler outputs results from the sum of the selected update time and a constant 3 msec. propagation delay of the optocoupler circuit itself.

Hence, the minimum delay time of the switching outputs to changes of the analogue input is about 53 msec.

9. Technical Specifications

9.1. Dimensions

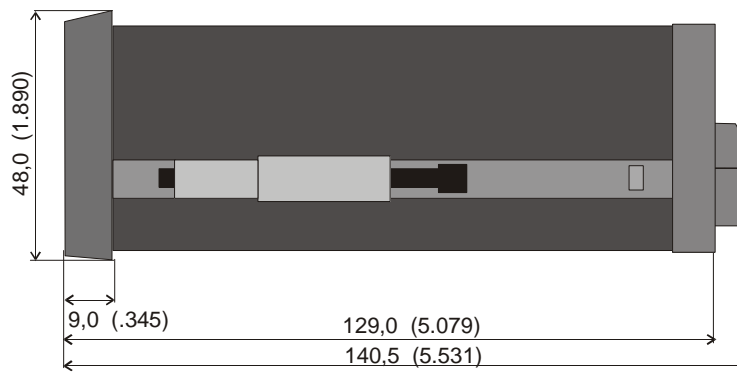
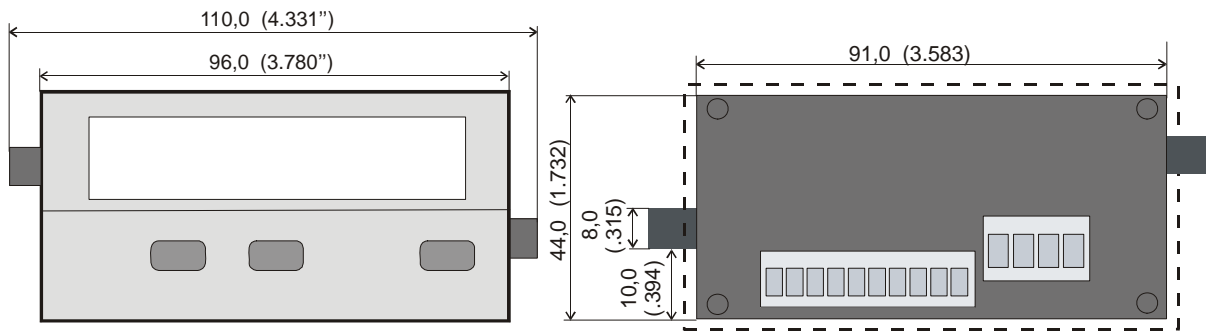

Panel cut out: 91 x 44 mm (3.583 x 1.732")

9.2. Technical data

Power supply AC	: 115/230 V (+/- 12,5 %), 7,5 VA
Power supply DC	: 24 V (17 – 30 V), approx. 100 mA (without aux. sensor supply)
Total AC power	: 7,5 VA
DC current consumption (without sensors)	: 18 V : 110 mA, 24 V : 90 mA, 30 V : 80 mA
Aux. output for sensors	: 24 V DC, +/- 15%, 100 mA (with AC and DC power input)
Inputs	: 2 analogue inputs (+/-10 V, 0 ... 20 mA, 4 ... 20 mA)
Input impedance	: Current: Ri = 100 Ohms, Voltage: Ri = 30 kOhms
Resolution	: 14 bits (13 bits + sign)
Accuracy	: +/- 0.1%, +/- 1 digit
Switching outputs (AX 347 only)	: 2 x PNP, max. 35 V, max. 150 mA minimum response time 53 msec.
Ambient temperature	: Operation: 0° - 45° (32 – 113°F) Storage: -25° - +70° (-13 – 158°F)
Housing	: Norly UL94 – V-0
Display	: 6 decades LED, high-efficiency orange, 15 mm (0.590")
Protection class	: IP65 (front), IP20 (rear)
Screw terminals	: Signal lines max. 1.5 mm ² (.0023 sq.in.) AC lines max. 2.5 mm ² (.0039 sq.in.)
Minimum update time	: 50 msec (display) : 53 msec (switching outputs)
Conformity and standards	: EMC 89/336/EEC: EN 61000-6-2 EN 61000-6-3 LV73/23/EEC: EN 61010-1

9.3. Commissioning Form

Date:	
Operator:	
Software:	
Serial No.:	

<u>Analogue Inputs</u>	Input A	Input B
Input range:	<input type="checkbox"/> Voltage +/- 10 V <input type="checkbox"/> Current 0 – 20 mA <input type="checkbox"/> Current 4 – 20 mA	<input type="checkbox"/> Voltage +/- 10 V <input type="checkbox"/> Current 0 – 20 mA <input type="checkbox"/> Current 4 – 20 mA
Start value:		
End value:		
Decimal point:		

<u>Basic settings</u>	Mode of operation:	<input type="checkbox"/> Single <input type="checkbox"/> A+B <input type="checkbox"/> A:B <input type="checkbox"/> Dual <input type="checkbox"/> A-B <input type="checkbox"/> AxB
Linearization:	<input type="checkbox"/> no <input type="checkbox"/> 1-quadrant <input type="checkbox"/> 4-quadrant	
Display Update-Time:		
Cmd key command:	<input type="checkbox"/> OFF <input type="checkbox"/> oFFSEt <input type="checkbox"/> tEACH <input type="checkbox"/> both	

<u>Combined modes:</u>	
(A+B, A-B, A:B, AxB)	Proportional Factor:
	Reciprocal Factor:
	Additive Constant:
	Decimal point::

<u>Switching Outputs (AX 347 only):</u>	Output 1	Output 2
Characteristics:	<input type="checkbox"/> <u>J</u> GE <input type="checkbox"/> <u>J</u> LE <input type="checkbox"/> <u>N</u> GE <input type="checkbox"/> <u>N</u> LE	<input type="checkbox"/> <u>J</u> GE <input type="checkbox"/> <u>J</u> LE <input type="checkbox"/> <u>N</u> GE <input type="checkbox"/> <u>N</u> LE <input type="checkbox"/> <u>J</u> 1-2 <input type="checkbox"/> <u>N</u> 1-2
Hysteresis:		
Preset values:		

<u>Linearization:</u>			
P01_X:	P01_Y:	P09_X:	P09_Y:
P02_X:	P02_Y:	P10_X:	P10_Y:
P03_X:	P03_Y:	P11_X:	P11_Y:
P04_X:	P04_Y:	P12_X:	P12_Y:
P05_X:	P05_Y:	P13_X:	P13_Y:
P06_X:	P06_Y:	P14_X:	P14_Y:
P07_X:	P07_Y:	P15_X:	P15_Y:
P08_X:	P08_Y:	P16_X:	P16_Y: