

Logic state transfers

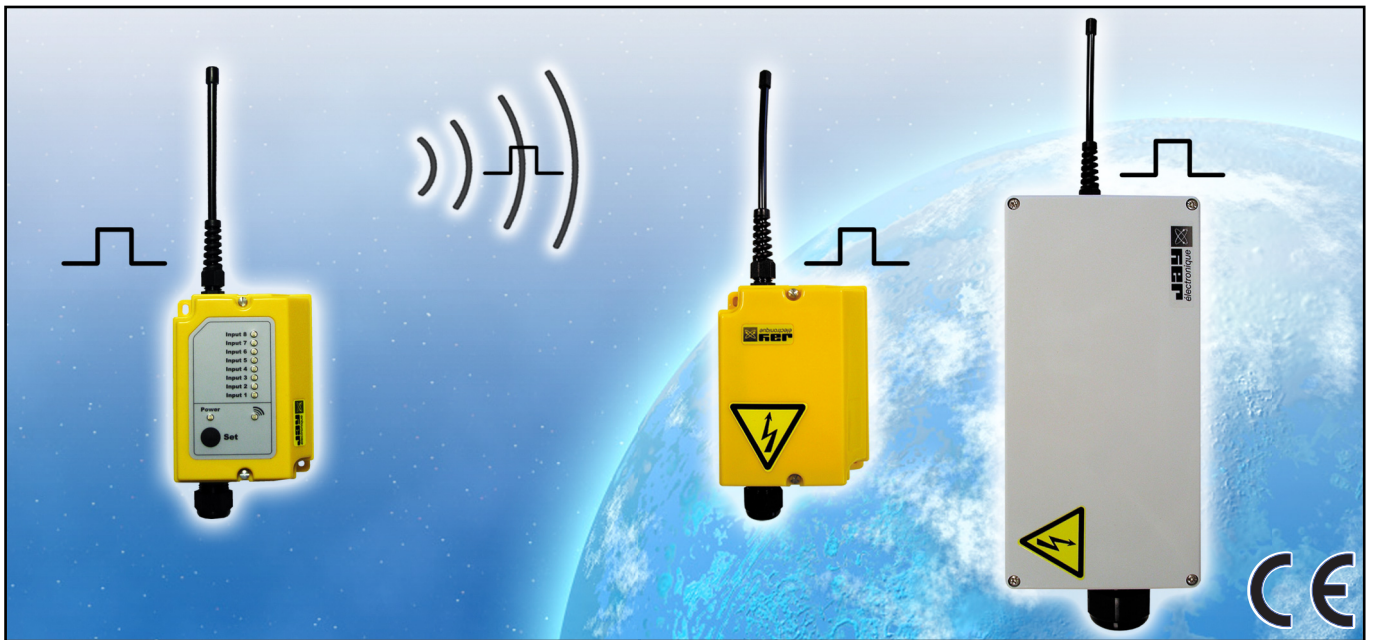

1- Typical applications

● Industrial equipment :

- Status transfer of isolated detectors to control room
- Status transfer of position detectors or alarm to programmable controller
- Status transfer of wire-guided trolleys or any other mobile equipment
- Remote control from control station to machines
- Remote control from machines to machines
- Transmission of statuses and controls from control panels to machines

● Industrial lifting :

- Anticollision on travelling cranes
- Remote control from fixed control panel / control room
- Control of mobile equipment to open doors

● Farm equipment :

- Status transfer concerning fill-height level of silos, tanks
- Remote pump control
- Feeder control
- Farm machinery
- Alarms

● Infrastructure :

- Remote control of lighting, ventilation
- Gate opening/closure control using mobile devices
- Parking sensor status indication

2- Description of the ISIS Series

The use of radio logic state transfers allows to get rid of electric cables linking equipment of an installation.

ISIS Series enables to :

- ➡ Lower your installation costs (wiring, civil engineering,).
- ➡ Increase the reliability of mobile equipment by eliminating the need for wear parts..
- ➡ Increase the flexibility of your installations.
- ➡ Decrease your operating costs related to maintenance.

● Compliance with European directives :

- Hertzian equipment and telecommunication terminals (low voltage, EM compatibility, radiofrequency spectrum)

CONTENTS

Para.	Page
1- Typical applications	p 1
2- Description of the ISIS Series	p 1
3- Operating principle	p 2
4- Safety aspects	p 2
5- Setting product	p 2
6- ISIS unit associations	p 4
7- Product installation	p 5
8- Technical characteristics	p 5
9- Electrical connections.....	p 6
10- Dimensions.....	p 7
11- Selection guide.....	p 8

3- Operating principle

The **ISIS** data transmission system is designed to transmit 8 logic states from one point of an installation to another.

The **ISE** transmitter sends the logic states of its inputs by radio to the receiver **ISR** which decodes the states and restores them on its relay outputs.

The logic states are transmitted on a radio channel with a coded identifier (identity code).

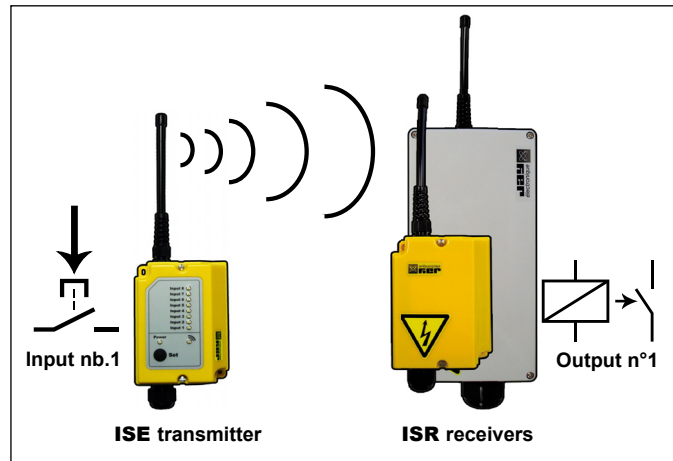

4- Safety aspects

To ensure reliable information transmission, the **ISIS** Series is defined with the following features :

- A radio link with non-directional and non metallic obstacle insensitivity characteristics ensuring optimum installation availability.
- A «Radio Quality» output on receiver for real time evaluation of radio link quality.
- A specific identity code to each transmitter / receiver pair or group (user programmable).
- A response time compatible with most controlled industrial equipment.
- A permanent radio link mode ensuring «positive» security (all interference is handled as an interruption of the signal transmitted on the inputs, generating a transition to the OFF state of «Radio Quality» then function outputs).
- A momentary radio link mode, made possible by use of a microswitch, enabling to combine several transmitters to a single receiver.

5- Setting product

For easier installation, the **ISIS** system is delivered «ready to use». However, if the installation is in a harsh environment (other radio systems present, long range...), the «factory» parameters (working radio frequency, identity code, transmitting mode, radio transmit power) can be easily modified by the user via DIP-switches inside the transmitter.

Working radio frequency

The **ISIS** Series has 18 radio channels in the frequency bands 433-434MHz :

Radio channel nb.:	1	2	3	4	5	6	7	8	9
Frequency (MHz)	433,100	433,200	433,300	433,400	433,500	433,600	433,700	433,800	433,900
Radio channel nb.:	10	11	12	13	14	15	16	17	18
Frequency (MHz)	434,000	434,100	434,200	434,300	434,400	434,500	434,600	434,700	434,740



Transmitter radio transmit power

The **ISIS** Series can operate with two different radio transmit powers : 1mW or 10mW
The choice of radio transmit power will depend on the application in which the **ISIS** product is used.

■ 1 mW radio transmit power :

If the installation has many radio systems and the range between the **ISIS** transmitter and receiver is short or if the response time of an output must be fast (less than 60ms max), it is preferable to select a transmit power of 1 mW.

■ 10 mW radio transmit power :

If the range of the **ISIS** transmitter-receiver is long and/or if the installation has many radio systems in 433-434MHz frequency band, it is preferable to choose a radio transmit power of 10 mW.



Transmitter radio transmission modes

The **ISIS** transmitter can operate with two different radio transmission modes : **Intermittent transmission** or **Continuous transmission**, the choice of transmission mode will depend on the application in which the **ISIS** product is used.

■ Intermittent radio transmission :

The transmitter only transmits provided at least one of its inputs is active.
This mode is recommended for applications where several transmitters are associated to a single receiver.

■ Continuous radio transmission :

The transmitter transmits whatever the state of its inputs.
This mode is recommended for applications where it is necessary to monitor the availability of the radio link.



«Radio quality» RM relay

To check the state of the radio link between transmitter and receiver, an output «Radio quality» is available on the receiver (relay «RM»).

■ «RM» relay activated :radio link between transmitter and receiver is good

■ «RM» relay deactivated :no radio link between transmitter and receiver

Note :

This function is only valid in continuous transmission mode or intermittent mode of emission as soon as an input is active.

6- ISIS unit associations

Several configurations are possible with **ISE** transmitter (8 logic inputs) and **ISRA** receiver (8 relay outputs) or **ISRS** receiver (4 relay outputs) :

Case nb.1

1 ISE transmitter
with 1 ISRA receiver

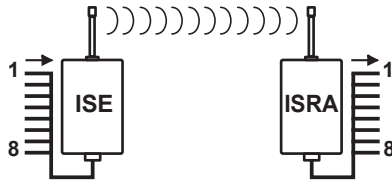

- Inputs 1 to 8 of transmitter are transferred to outputs 1 to 8 of the receiver.
- The radio link can be in permanent or intermittent mode on active input.
- The working frequency and the identity code are the same for both ISIS units.

Case nb.2

1 ISE transmitter
with 1 ISRS receiver
and 1 ISRA receiver

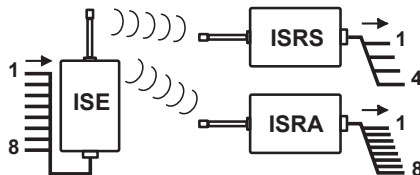

- Inputs 1 to 4 of transmitter are transferred to outputs 1 to 4 of ISRS receiver.
- Inputs 1 to 8 of transmitter are transferred to outputs 1 to 8 of ISRA receiver.
- The radio link can be in permanent or intermittent mode on active input.
- The working frequency and the identity code are the same for all ISIS units.

Case nb.3

1 ISE receiver
with N ISRS receivers
or with N ISRA receivers

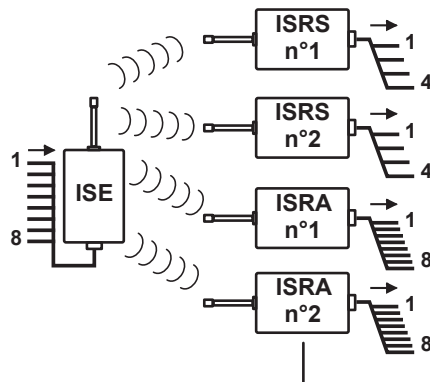

- **Case for ISE / N ISRS :**
Inputs 1 to 4 of transmitter are transferred to outputs 1 to 4 of receiver nb.1 to nb.N.
- **Case for ISE / N ISRA :**
Inputs 1 to 8 of transmitter are transferred to outputs 1 to 8 of receiver nb.1 to nb.N.
- The radio link can be in permanent or intermittent mode on active input.
- The working frequency and the identity code are the same for all ISIS units.
- An infinite number of receivers can be attributed to the transmitter.

Case nb.4

N ISE transmitters
with 1 ISRA receiver
or with 1 ISRS receiver

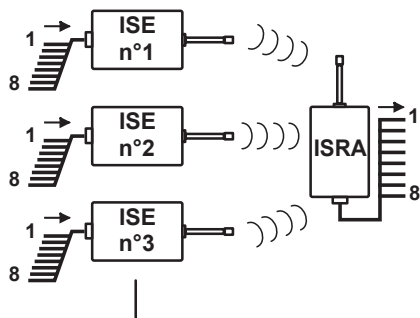

- Inputs 1 to 8 of transmitter are transferred to outputs 1 to 8 of ISRA receiver.
- Inputs 1 to 4 of transmitter are transferred to outputs 1 to 4 of ISRS receiver.
- For this configuration, you must check that :
- The transmitters cannot transmit simultaneously.
- The information to be sent is of short duration.
- The best way to get around these constraints is to ensure that the transmitters can only transmit in turn, one after the other.
- The radio link is necessarily in intermittent mode.
- The working frequency and the identity code are the same for all ISIS units.

Case nb.5

N ISE transmitters
with N ISRA receivers
or with N ISRS receivers

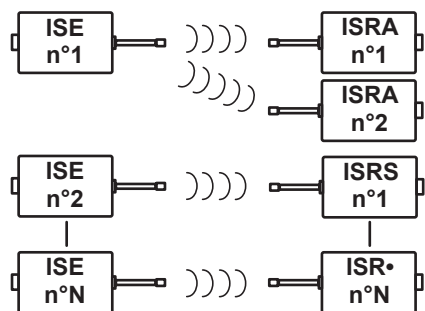

- Inputs of transmitter nb.1 are transferred to outputs of receiver nb.1 and so on.
- All the transmitters can transmit at the same time with no mutual interference provided a different radio channel and a different identity code are used for each pair.

Note: the assignment input / output is fixed and cannot be changed.

7- Product installation

General information

- Any obstacle between the transmitter antenna and the receiver antenna will reduce the range of the assembly.
- The radio waves do not travel through metal walls. The antennas must therefore not be placed in an enclosure forming a shield, such as a metal cabinet, a reinforced concrete wall, a steel structure or metal wall, etc. In such cases, the antenna must be entirely exposed. Failure to do so will result in strongly downgraded performance (BNC antenna kit must be used in this case, ref.: **OWR01**, see next page).

Particular cases

If several several radio systems coexist on the same site, precautions for installation should be taken. Please contact our technical support to help you validate your installation.

8- Technical characteristics

Common radio characteristics :

Frequency band : ISM 433-434Mhz
Radio channels : 18 user-programmable radio channels. Steps 100KHz from 433,1 to 434,7MHz, the 18th 434,740MHz
Effective radiated power : 1mW or 10mW depending selection
Average range (1) : In unobstructed area (1mw) : 200m In unobstructed area (10mw) : 350m In typical industrial environment (1mw) : 80m In typical industrial environment (10mw) : 100m

(1) = Range will vary according to environment conditions of transmitter and reception antenna (metal frameworks, walls ...).
The range will be decreased if one of the products is mounted on a moving equipment.

Technical characteristics for ISE transmitter :

Housing : Material : ABS Color : Yellow Tightness : IP65 Dimensions : 92 x 123 x 50 (without CG and antenna) Weight : 270 g Cable lead-outs : Cable gland PG 13,5 (Ø 8 to 12 mm)
Power supply : Type : DC , Voltage rane : 9V to 30VDC
Max / Min consumption : from 100mA to 200mA
Power supply protection : Fuse 250 mA on support
Low level on input : DC Voltage < 2 V
High level on input : DC Voltage > 3 V
Consumption of an input active in the high state : < 20 mA
Maximum voltage level on an input with no damage : 30 V
Antenna : Fixed (standard) or BNC external type ref.: VUB084 with kit ref.: OWR01
Operating temperature range : -20°C to +50°C
Storage temperature range : -30°C to 70°C
Maximum frequency of a signal on an input (continuous or intermittent transmission mode) : 1mW Mode = 10Hz max 10mW Mode = 0,5Hz max

Technical characteristics for ISRx receivers :

Housing : Material : ABS Color : ISRS = Yellow / ISRA = Grey Tightness : IP65 Dimensions : ISRS = 92 x 123 x 50 (without CG and antenna) ISRA = 240 x 120 x 100 (without CG and antenna) Weight : ISRS : 350 g / ISRA : 1200 g Cable lead-outs : ISRS : Cable gland PG 13,5 (Ø 8 to 12 mm) ISRA : Cable gland M32 (Ø 20 to 26 mm) + plastic cap for a possible cable gland M16 (Ø 5 to 7 mm).	
ISRS receiver power supply : 1 DC / AC Model : 12VDC (9 to 20VDC) 24VDC (20 to 75VDC) 24 VAC (+10%/-5%) 48 VAC (+10%/-15%)	ISRA receiver power supply : 1 DC Model : 12VDC (9 to 20VDC) 24VDC (20 to 28VDC) 1 AC Model : 24 VAC (+10%/-15%) 48 VAC (+10%/-15%)
Max consumption : DC : 180mA (ISRS) / 260mA (ISRA) AC : 5VA (ISRS) / 11VA (ISRA)	
Number of outputs : ISRS : 4 function outputs + 1 «Radio Quality» output ISRA : 8 function outputs + 1 «Radio Quality» output	
Type of output : Relay with 1 NO contact	
Antenna : Fixed (standard) or BNC external type ref.: VUB084 with kit ref.: OWR01	
Tuner sensitivity : < 2µV	
Power supply protection : 1 fuse on support (rated in accordance with power supply voltage and receiver models)	
Operating temperature range : -20°C to +50°C	
Storage temperature range : -30°C to 70°C	
Response time of an output when an input is activated or deactivated (continuous or intermittent radio transmission mode) : 1mW Mode : < 60ms 10mW Mode : < 500ms	
Passive shutdown time (radio jamming) : 2 seconds on a function relay 1,9 second on the «Radio quality» relay (RM)	

Receiver relay characteristics :

- Contacts : AgNi 0,15
- Max. power at $\cos\phi=1$: 2000 VA
- Max. current switching : 8 A
- Max. voltage switching : 400 VAC
- Minimum Current / Voltage advised switching : 100 mA / 12 VDC
- 100 000 switching cycles at 250 VAC, 8 A, $\cos\phi=1$
- 50 000 switching cycles at 24 VDC, 8 A
- Tests per EN 60947-5-1 :
DC13 - 0,5 A / 24 VDC
AC15 - 3 A / 250VAC

Number of switching cycles on various contactors :

Contactor	Physical unit switched by relay	Number of switching cycles for output relays
CA2DN LC1D09 LC1D18 LC2D09	Switching under 230VAC (70VA, $\cos\phi=0,75$)	2×10^6
	Switching under 110VAC, (70VA, $\cos\phi=0,75$)	1×10^6
	Switching under 48VAC (70VA, $\cos\phi=0,75$)	$0,5 \times 10^6$

9- Electrical connections

IMPORTANT :

The electrical connections should be made such that when the main switch is off, the **ISR** receiver is also deactivated.

ISE transmitter power supply :

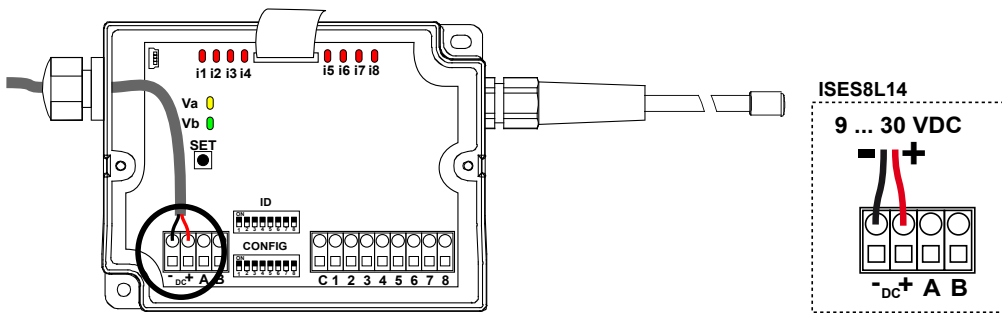

ISRA receiver power supply :

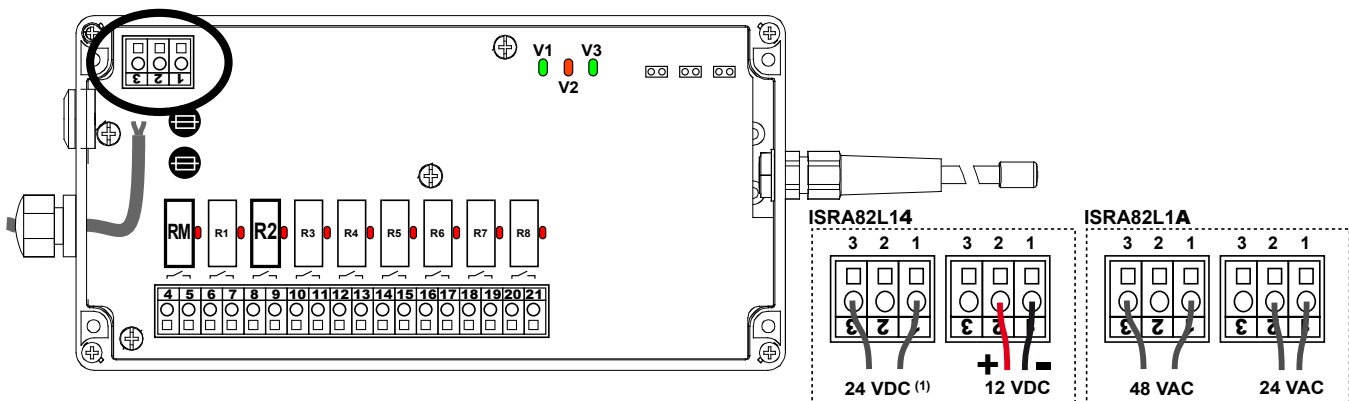

ISRS receiver power supply :

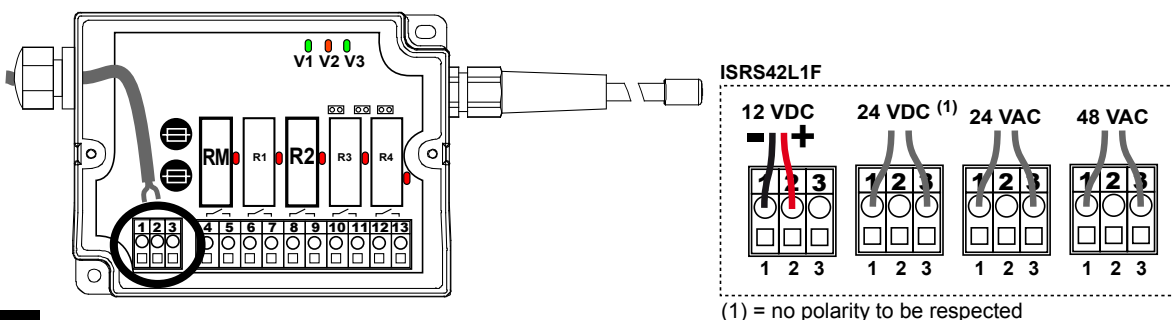

(1) = no polarity to be respected

Connection of inputs on ISE transmitter :

Here are the various possibilities of input connections :

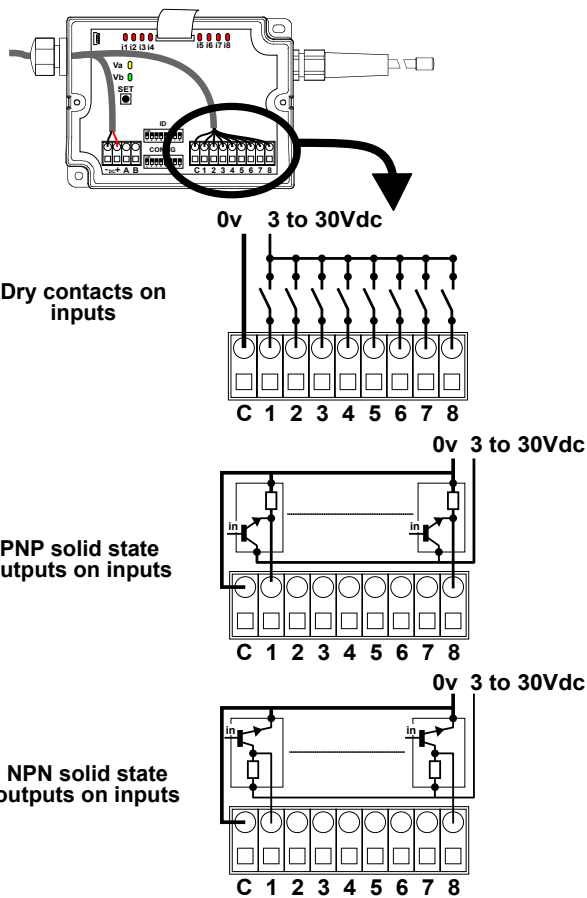

Connection of outputs on ISR receivers :

Example of use of the receiver relay outputs :

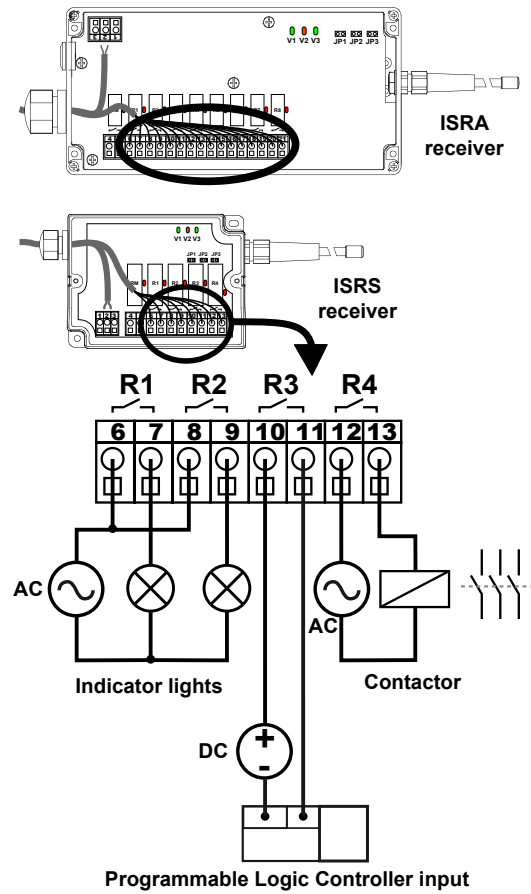

10- Dimensions

ISE transmitter and ISRS receiver :

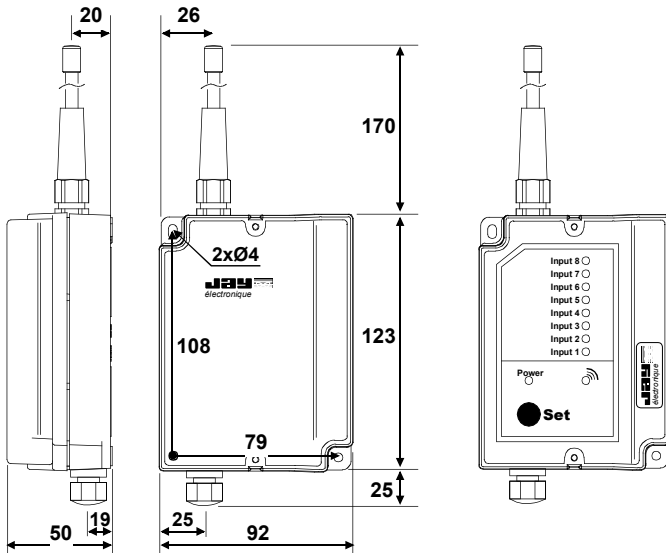

ISRA receiver :

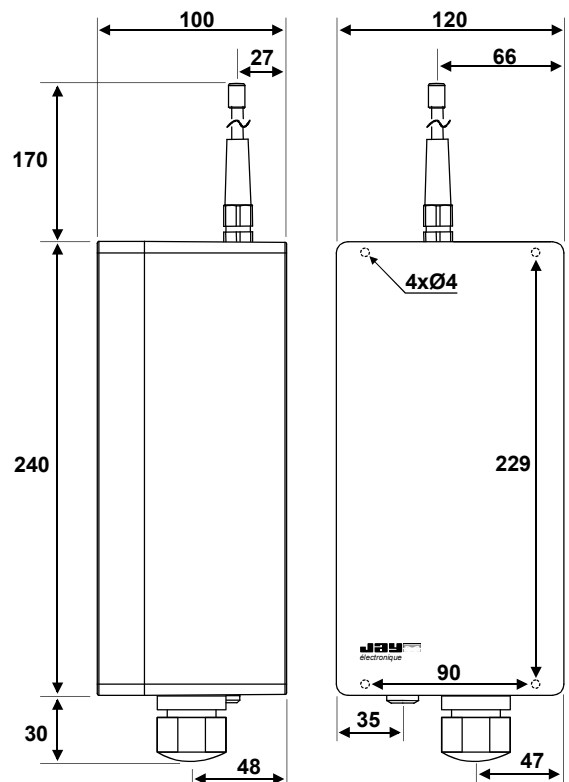

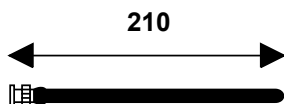

VUB084 Plug-in BNC antenna :

(To be used with BNC kit ref. : OWR01)



11- Selection guide, references for ordering

Sales references for ISIS units

	ISES8L14	Transmitter 8 Logic inputs, 433-434MHz, 12-24VDC
	ISRS42L1F	Receiver 4 relay outputs, 433-434 MHz, 12-24VDC & 24-48VAC
	ISRA82L14	Receiver 8 relay outputs, 433-434 MHz, 12-24VDC
	ISRA82L1A	Receiver 8 relay outputs, 433-434 MHz, 24-48VAC

Accessories :

External antenna :

Transmitters and receivers are delivered with a fixed antenna, if the optimum installation conditions are not observed (installation in cabinet, for example), it is necessary to use an external antenna with extension cord (BNC connector).

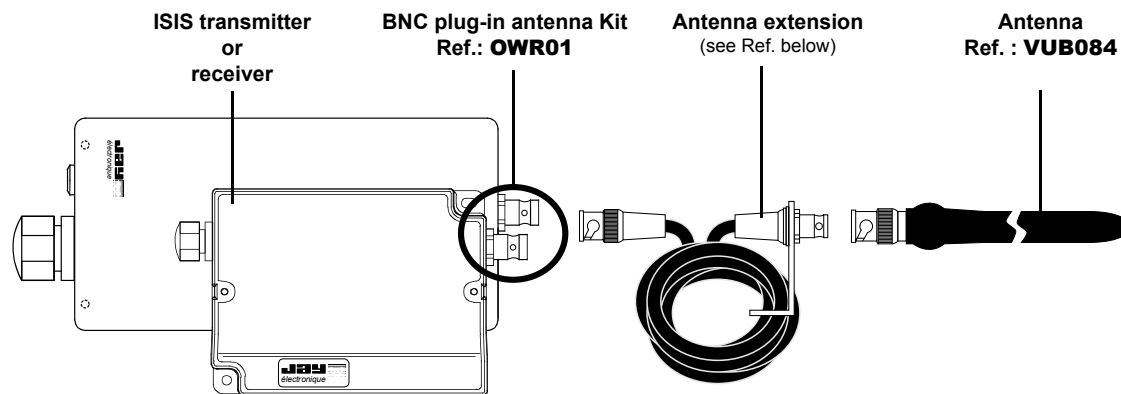

- OWR01**BNC plug-in antenna Kit
- VUB084**.....BNC plug-in antenna, 1/4 wave 433-434MHz
- VUB170**.....0,5m extension (BNC connector), without bracket
- VUB105**.....2m extension (BNC connector), with bracket
- VUB125**.....5m extension (BNC connector), with bracket
- VUB131**.....10m extension (BNC connector), with bracket

IMPORTANT :

JAY Electronique shall not be liable for use made of any other extensions or antennas other than those recommended above. The performance of the transmit antenna may not satisfy the requirements of the currently applicable standards.

Other accessories :

- UDWR38**Fastening Kit for **ISIS** unit by 4 magnetic contacts (installation on metal surface)

The products presented in this document are subject to change. Product descriptions and characteristics are not contractually binding. Please go to our internet site www.jay-electronique.fr to download the most recent updates to our documentation.

E830 A - 0309

revision02



Headoffice and plant :
 ZAC la Bâtie, rue Champrond
 F38334 SAINT ISMIER cedex
 Tel. :+33 (0)4 76 41 44 00
 Fax :+33 (0)4 76 41 44 44
 Web :www.jay-electronique.fr

Distributor
 ELEKTRO-TRADING sp. z o.o.
 Tel. +48 32 330-45-70
 Fax. +48 32 330-45-74
www.elektro-trading.com.pl

28.03.09 - E.Drehanne