

GMIX2 series - magnetic, incremental Length - Measuring - System

With GMIX2, ELGO-Electric offers an incremental measuring system, which can be installed with a distance from up to 4 mm to the magnetic tape. With a resolution of 2.5 mm (repeating accuracy +/- 2.5 mm) and a max. operation speed of 10 m/s (output frequency 4 KHz), GMIX2 is suitable for applications in storage- or conveyor- techniques resp. for longer distances. Thanks wear-free measuring-principle (by magnetic scanning) and high protection class of IP67, the system works in rough environments always uninfluenced and reliably. The translator circuit, which converts the detected signals into 90° shifted square wave signals A and B (like output signals of rotary encoders), is already in the sensor head integrated. Thus GMIX2 can be connected directly to follow-up circuits (e.g. position indicator). The system is supplied with 10... 30 VDC. The output signals are HTL - according to supply level.

Technical specifications

General datas

Resolution	:	2.5 mm (at 4 edge triggering)
Repeating accuracy	:	+/- 2.5 mm
Accuracy at 20° C in mm's	:	+/- (1.25 + 0,02 x L) L = effective measuring length in meters
Distance tape/sensor	:	max. 4,0 mm
Power supply voltage	:	10... 30 VDC, stabilized
Output levels	:	HTL 10.. 30 VDC (according to supply voltage, less approx.. 0.7 V)
Material of housing	:	HM-PA (Polyamide), black
Protection class (sensor head)	:	IP 67
Operation temperature	:	0 ° up to + 50 °C
Output current	:	max. 20 mA per channel
Outputs	:	push/pull, durable short circuit proof
Consumption	:	ca. 30 mA
Output frequency	:	4 kHz (per channel A or B)
Operating speed	:	max. 10,0 m/s
Cable length	:	on request max. 30 m possible

Datas of magnetic tape MB 20.50 (accessories)

Operation temperature	:	0° up to + 60°C
Linear expansion coefficient	:	16×10^{-6} 1/K
Bending radius	:	minimal 150 mm
Protection class	:	IP65

Dimensions of sensor

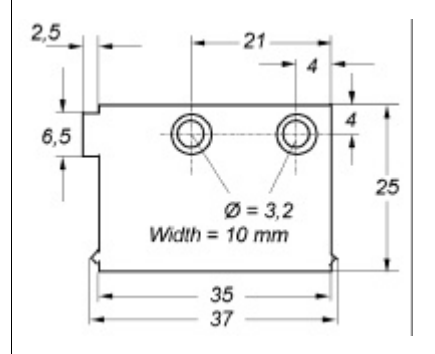

Type designation

GMIX2 - XXX - XX.X

Series/Type

SN-Number

000 = standard

001 = first special version

002... etc.

Length of signal cable XX.X m (1, 3, 5, 8 or 10 m)

Magnetic tape MB20.50 (accessories)

MB20.50 - XX.X

ELGO-Magnetic tape 5 mm's Pole division

Length (in m)

(1 standard roll up to max 32 m, on request up to 1000 meters available)