

# Application 1: Basic Speed Control

IDEAL FOR GENERAL PURPOSE APPLICATIONS  
NORMAL DUTY AND HEAVY

**P 1** = 1

*Italic text indicates Default*

### STANDARD PARAMETERS

- p1 Application
- p2 Max speed
- p3 Min speed
- p4 Accel time
- p5 Decel time
- p6 Motor current
- p7 Base frequency
- p8 Jog setpoint
- p9 Run stop mode
- p11 V/F shape
- p12 Normal duty
- p13 Fixed boost, (VF only)
- p99 Password

### DIAGNOSTICS

- Frequency Hz
- Speed Setpoint %
- DC Link Volts V
- Motor Current A

**Application 1 : Basic Speed Control (default)**

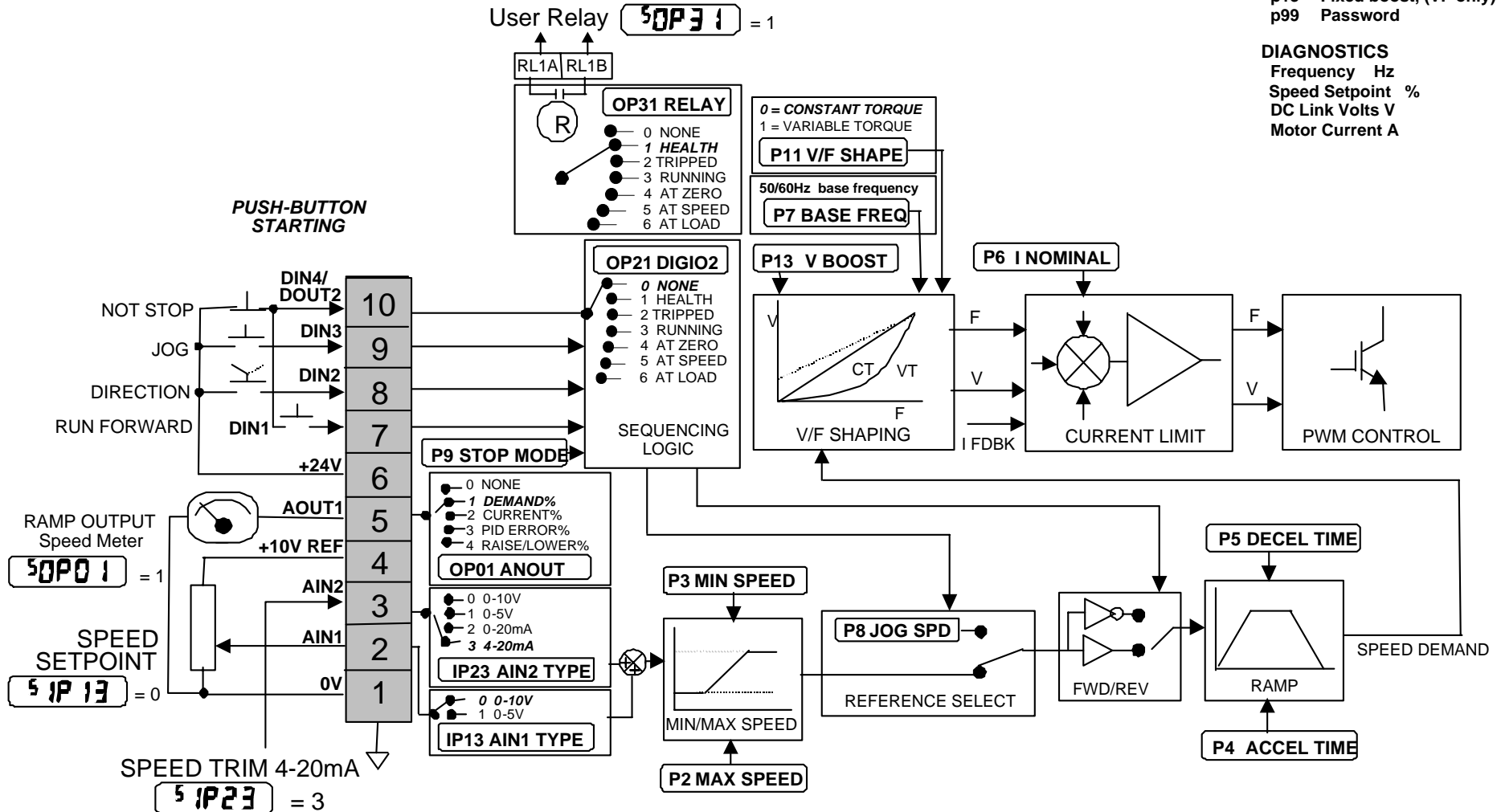

## Application 1: Basic Speed Control (default)

This Application is ideal for general purpose applications. It provides push-button or switched start/stop control. The setpoint is the sum of the two analogue inputs AIN1 and AIN2, providing Speed Setpoint + Speed Trim capability.

