

ZU 251

Incremental Counter Module With Analogue Output and Serial Interface



- Counter suitable for quadrature signals (A/B, 90°) as well as single channel inputs
- Counting inputs selectable to TTL/ RS422 format or to HTL / 10-30 volts format
- Maximum counting frequency 500 kHz
- Analogue outputs +/-10 V, 0-20 mA and 4-20 mA, polarity following the sign of the internal counter
- Analogue conversion time 1 msec only
- RS 232 and RS 485 interfaces for serial readout of the counter
- Also suitable for conversion of the sum or the difference of two separate counts
- Facility for free linearization of the analogue output by 16 interpolation points
- Easy to set up by TEACH procedure, or by PC and Windows software

Operating Instructions



Safety Instructions

- This manual is an essential part of the unit and contains important hints about function, correct handling and commissioning. Non-observance can result in damage to the unit or the machine or even in injury to persons using the equipment!
- The unit must only be installed, connected and activated by a qualified electrician
- It is a must to observe all general and also all country-specific and application-specific safety standards
- When this unit is used with applications where failure or maloperation could cause damage to a machine or hazard to the operating staff, it is indispensable to meet effective precautions in order to avoid such consequences
- Regarding installation, wiring, environmental conditions, screening of cables and earthing, you must follow the general standards of industrial automation industry
- - Errors and omissions excepted –

Version:	Description:
ZU25101B/ HK/AF/ Nov.01	Original version
ZU25102A/ HK/AF/ Mar04	New parameters: Power-up-Mode, Protocol setting

Table of Contents

1.	Introduction	4
2.	Applicable encoders and sensors	5
3.	Terminal Assignment	6
3.1.	Incremental encoders TTL / RS 422	6
3.2.	Incremental encoder HTL / 12-30V	7
3.3.	Proximity switches, photocells etc.....	7
3.4.	Analogue outputs	7
3.5.	Serial interfaces	8
4.	DIL switch settings.....	9
5.	Setup Procedure.....	11
5.1.	Operation as single channel counter (without direction signal) or as positional counter (with direction signal).....	12
5.2.	Operation as a summing or differential counter with two independent impulse inputs (A+B, A-B).....	12
6.	Readout of the actual counter state by serial communication	13
7.	PC setup with use of the operator software OS3.x.....	14
8.	Displays and Softkeys.....	15
9.	Parameter Settings	16
10.	Free Programmable Linearization.....	21
11.	Test Functions	23
12.	Dimensions	24
13.	Technical Specifications	25
14.	Parameter List.....	26

1. Introduction

ZU 251 represents a small and low-cost, but highly performing converter for industrial applications, where incremental counting of positions or events must be converted to either analogue format or serial data. The unit has been designed as a compact module with 12 screw terminals and a 9-position SUB-D connector (female). The housing is suitable for standard DIN rail mounting.

The impulse input side provides channels A, B and also the inverted lines /A, /B which must be used with TTL/ RS422 input signals. The unit can count and convert the following formats to analogue and serial:

- a. Up/down count with quadrature input (A/B, 90°).
The polarity of the analogue output and the sign of the serial data depend on the sign of the actual counting result
- b. Single channel impulses on channel A.
Input B sets the counting direction and therefore also the polarity of the output (LOW = negative, HIGH = positive).

Please observe:

- Open NPN inputs are HIGH
 - Open PNP inputs are LOW
 - Open RS422 inputs are HIGH
- c. Dual count of fully independent events on channels A and B, where the output signal represents the sum or the difference of both counts.

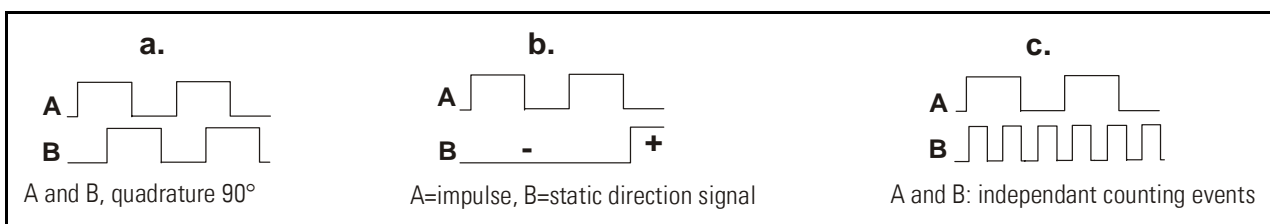

The definitions for “zero analogue output” and “full scale analogue output” definition can be set over the full counting range of +/-8 decades (-99 999 999 to +99 999 999)

2. Applicable encoders and sensors

The converter can accept the following impulse sources:

- Encoders with HTL level output (12–30V) and either PNP or NPN or Push-Pull or NAMUR characteristics, using quadrature output signals A and B
- TTL / RS422 encoders providing the output lines A, /A, B and /B
- Single channel sources like proximities or photocells, providing HTL output and PNP or NPN or NAMUR characteristics
- Single channel sources with TTL/ RS422 output, providing both, signal and inverted signal (differential operation)

In general, HTL encoders will be supplied from the same source as the converter itself.

For supply of TTL encoders, the unit provides an auxiliary output of 5.5 volts stabilized, (150 mA max.)



For applications using single-ended TTL signals A, B only (i.e. without associated inverted signals /A, /B) : See successor model ZU252

3. Terminal Assignment

We recommend connecting the Minus wire of the power supply to earth potential. Please observe that, under poor earthing and grounding conditions, multiple earth connections of screens and GND terminals may cause severe problems. In such cases it may be better to have only one central earthing point for the whole system.

GND terminals 4, 6 and 12 are connected internally. Depending on input voltage and load of the auxiliary voltage output, the total power consumption of the unit is approx. 150 mA (see specifications).

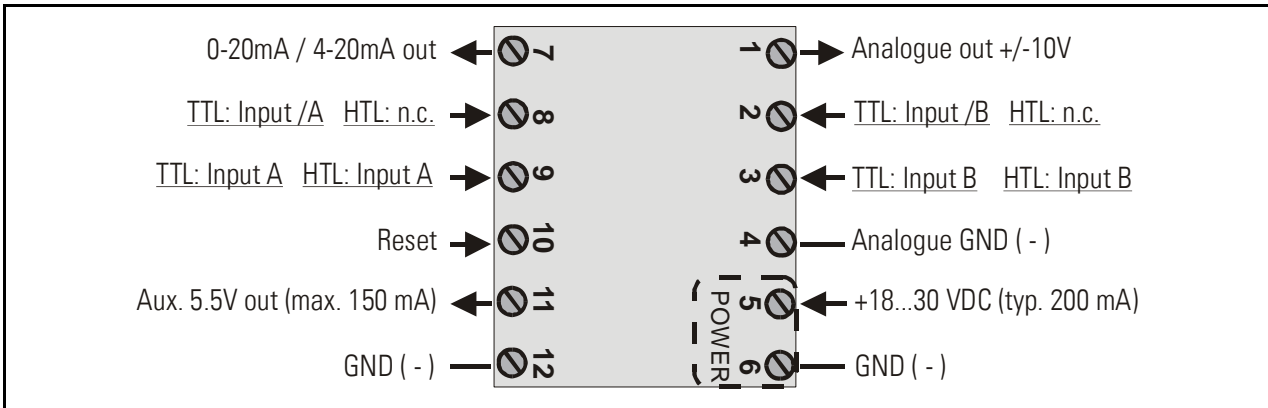

3.1. Incremental encoders TTL / RS 422

If applicable, the encoder can be supplied from the ZU251 converter. Where the encoder is already supplied from a remote source, we recommend fully differential operation, with no GND connection between encoder and converter (see figures a. and b.)

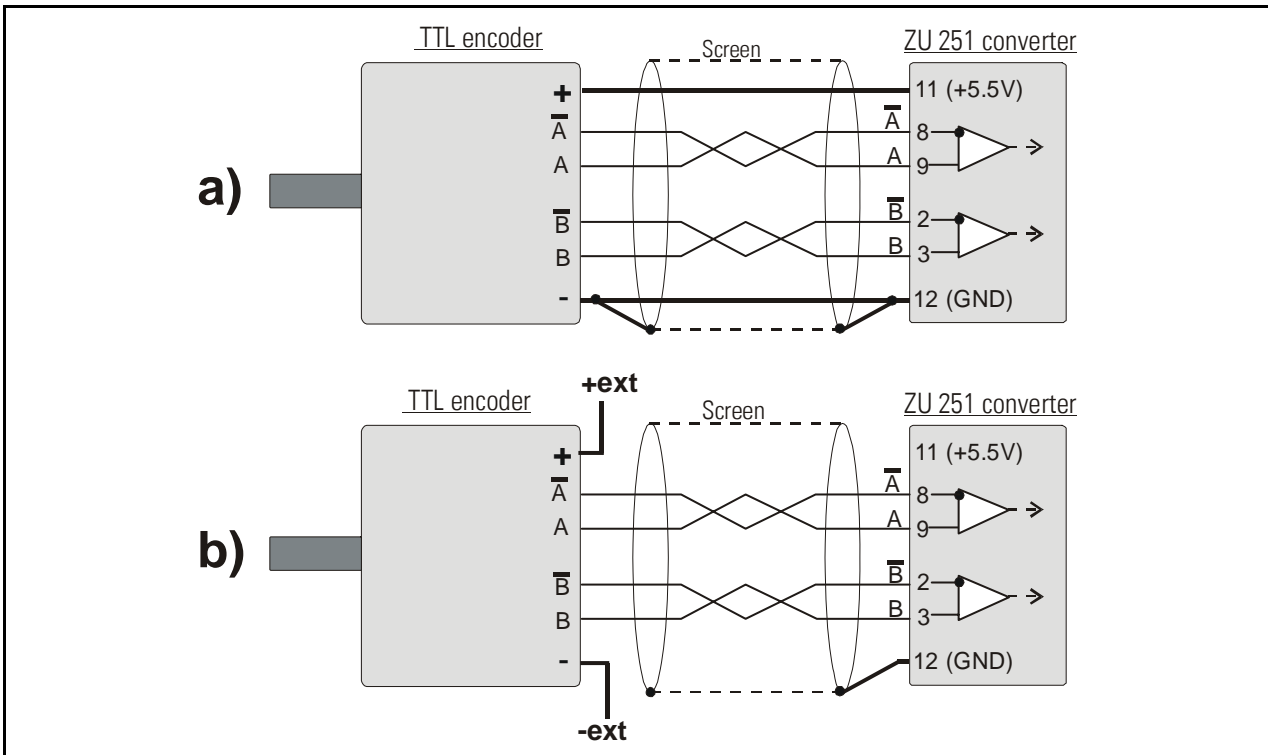

3.2. Incremental encoder HTL / 12-30V

The encoder may be supplied from the same source as the converter, or from another source.

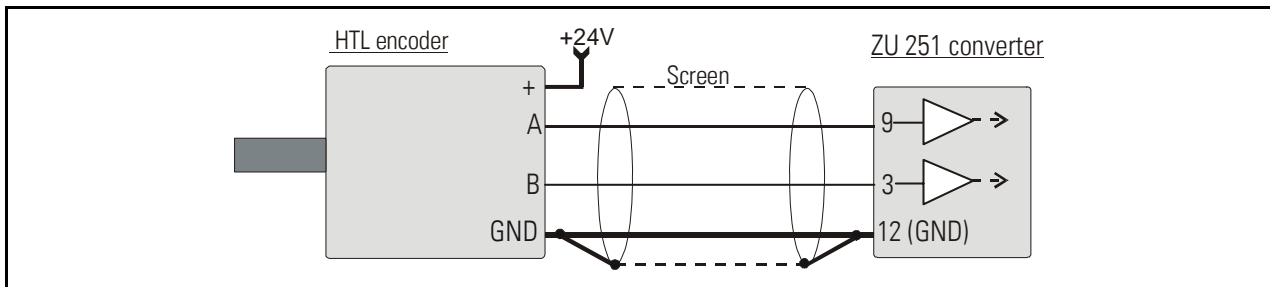

3.3. Proximity switches, photocells etc.

This connection is fully similar to a HTL incremental encoder. With single-channel operation, input B remains unconnected or can be used to select the output polarity. With use of two independent counting events for forming the sum or the difference, input B operates as the second counting input.

For use of sensors providing 2-wire **NAMUR** characteristics:

- Set the inputs to HTL and NPN
- Connect the positive wire of the sensor to the corresponding input and the negative wire to GND.

3.4. Analogue outputs

The unit provides a +/-10V voltage output and a 0-20 mA / 4-20 mA current output at a resolution of 14 bits, i.e. the voltage output operates in steps of 1.25 mV and the current output operates in steps of 2.5 μ A. The nominal load of the voltage output is 2 mA, the current output accepts loads between 0 Ohms and 270 Ohms.

The analogue ground uses a separate terminal, which however internally is connected to the GND potential of the power supply.

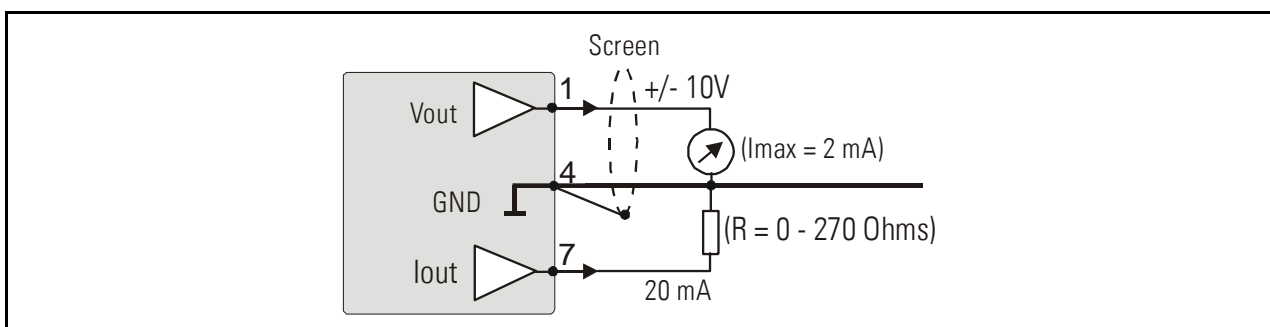

3.5. Serial interfaces

The unit provides a RS232 interface and a RS485 interface, however only one of the two can be used at a time. Serial communication allows to read out the counting result and to set parameters and variables by PC, according to need.

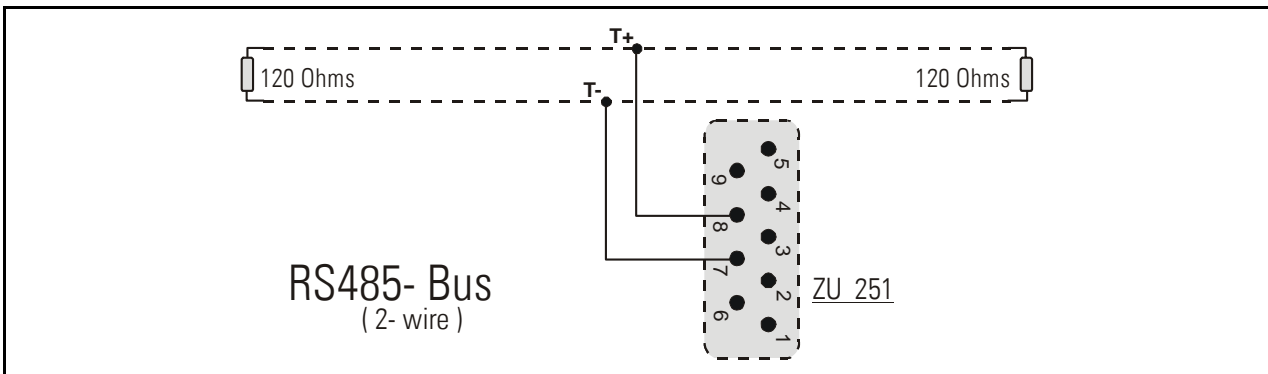
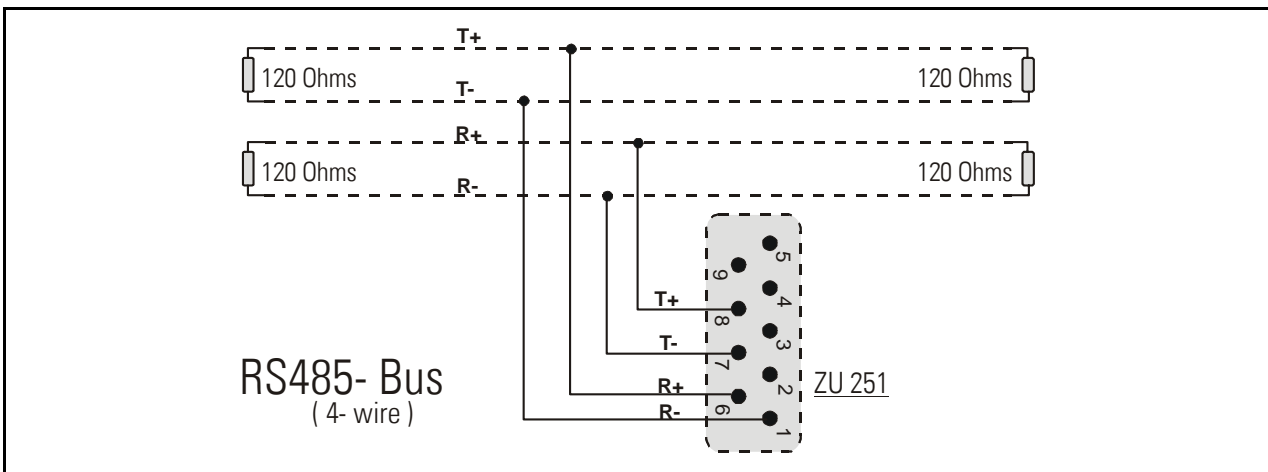
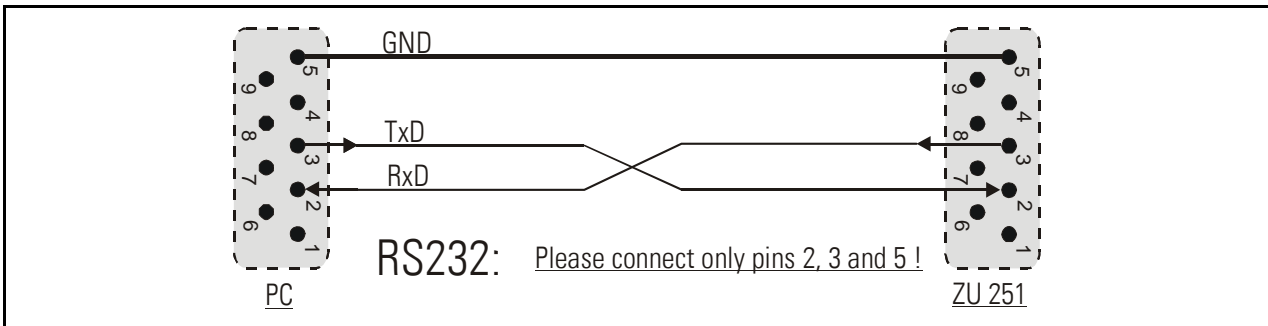
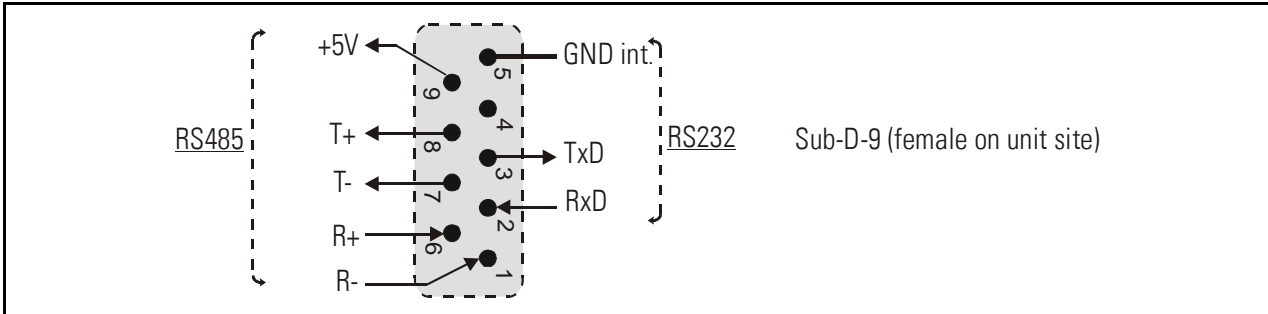

4. DIL switch settings

The DIL switch located on the top site of the unit provides customer-specific settings of the desired operation modes.



Changes of the switch settings will become active only after the next power-up cycle!

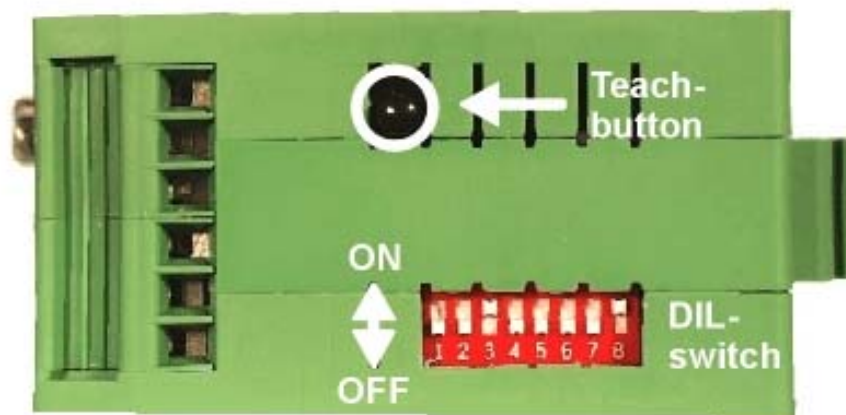

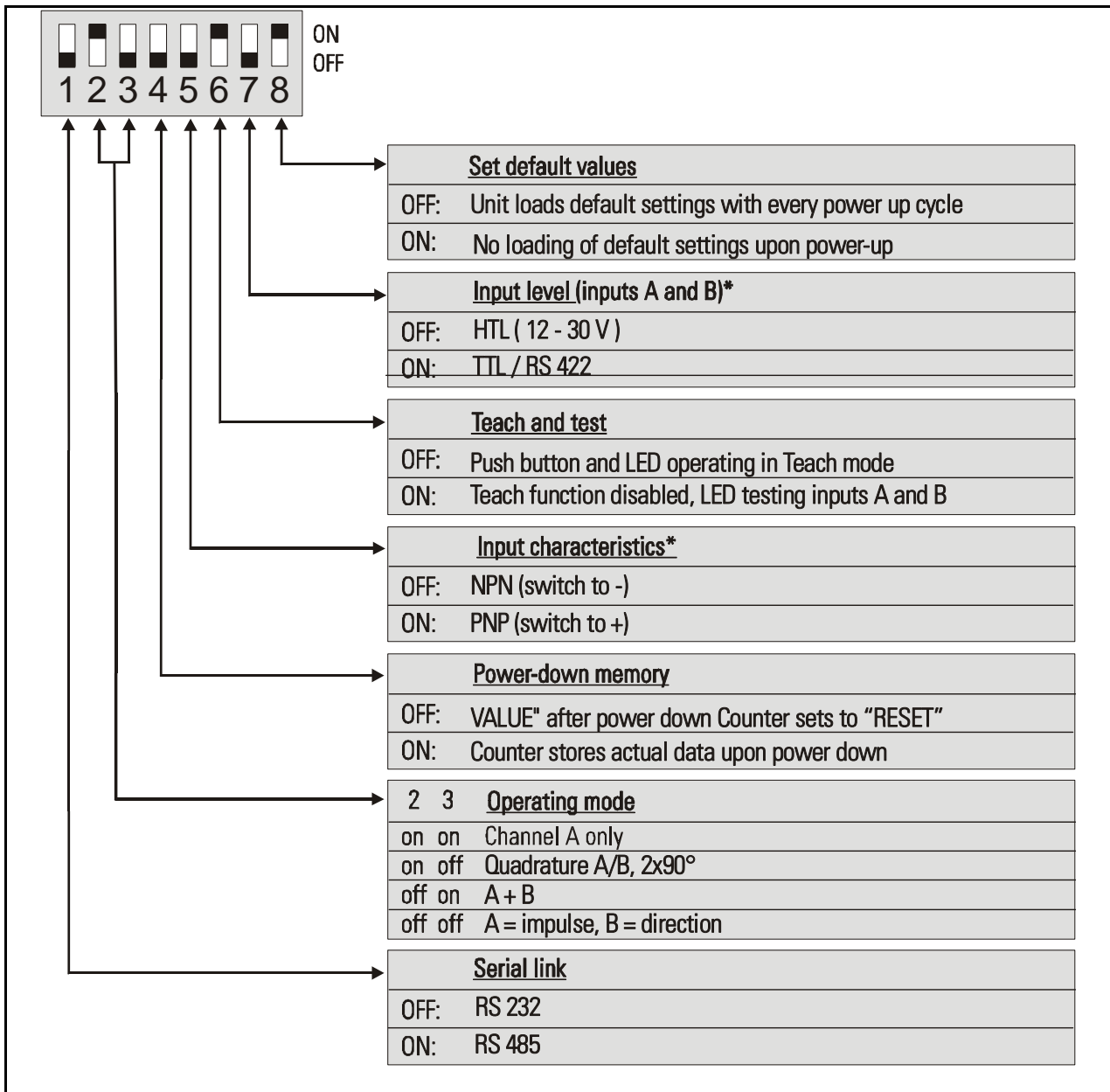

The switch settings shown in the example are suitable for a quadrature encoder with HTL- and NPN characteristics. The power-down memory is switched off and the serial link is set to RS232 communication.



After setup and commissioning, please set DIL switch position 6 to ON. If set to OFF, any inadvertently touch of the „Teach“ button would overwrite your previous scaling input !

*) These settings refer to the impulse inputs A/B only. The RESET input (terminal 10) however always uses HTL and PNP characteristics and you must apply a voltage of 12 to 30 volts to activate the Reset function.

5. Setup Procedure

For all basic applications you can use the Teach feature for commissioning of the unit. Extended functions need a PC for setup and are described under section 7.

As a first step it is advisable to check the input pulses by means of the LED marked "Status". DIL switch 6 must be set to ON for this test.

When you press the TEACH button one time, the yellow LED will be lit after the unit detected a pulse on input A. The LED will be OFF when no input pulse has been detected.

When you press the TEACH button once more, you can also check input B (if applicable). With use of mode A+B and two independent impulse sources, again the yellow LED will be lit after a pulse has been detected on input B.

With operation modes using input B to define the direction and polarity (quadrature or static), the yellow LED will indicate that the actual input signals provide a positive signal on the analogue output (LED on) or a negative signal (LED off). Where you like to get the other polarity, you must change the information of direction on A/B inputs

5.1. Operation as single channel counter (without direction signal) or as positional counter (with direction signal)

- **Settings:** Make sure that the DIL switch is set according to the encoder in use, and that DIL switch position 6 is OFF (Teach function active).
- **Self test:** Upon power up, both front LED's must be lit first, and the yellow status LED must switch off after the self-test has been concluded successfully (approx.1 sec.).
- **Scaling of the analogue output with use of the Teach function:**

Press the Teach button one time. The status LED will blink in a slow sequence now while the unit waits for setting of the minimum counter state, this is the state where later you expect the analogue output to be zero (in general, this will be with counter=0). Please set the counter to the desired state or move the encoder to the desired position and reset the counter to zero. Then press the Teach button again. This stores your minimum counter definition.

The LED will blink in a fast sequence now and the unit waits for setting of the maximum counter state, this is the state where later you expect full scale analogue output. Please get the counter to the desired state or move your encoder to the desired position. Then press the teach button once more. This stores your maximum counter definition and the LED will switch off.

After this Teach procedure, your analogue output is set to 0–10 volts swing between the minimum and the maximum counter state.

5.2. Operation as a summing or differential counter with two independent impulse inputs (A+B, A-B)

In principle, the Teach procedure is exactly the same as shown under 5.1, but the minimum and maximum counter states already refer to the sum or the difference of the count on both inputs.

6. Readout of the actual counter state by serial communication

At any time you can read out the actual counter state and more values via serial link. For setting of serial communication parameters etc., you must however apply PC setup anyway, as shown later.

ZU 251 uses the DRIVECOM communication protocol according to the ISO 1745 standard. Details about the protocol can be found in our document "[SERPRO.doc](#)", available for download under

www.motrona.com

The following register codes are available for readout:

C1	C2	Description
:	8	Actual conversion result, scaled as % of full scale output, format xxx.xxx % *)
:	9	Actual counting result
;	3	Actual output voltage of the analogue output, scaling 0 – 10 000 millivolts

*) under consideration of the scaling operands as shown in section 9.

$$\text{Readout from } \langle 8 \rangle = \text{Counter result in \% of full scale} \times \frac{\text{xOperand}}{\text{/Operand}} + \text{+/-Operand}$$

7. PC setup with use of the operator software OS3.x

You can apply the full set of functions when you use a PC and our operator software OS3.x for setup of the unit (actual software version is OS3.2).

You can download this software and more instructions from our homepage

www.motrona.com

Connect your PC to the converter, using a serial RS232 cable like shown in section 3.5 of this manual. Make sure the cable only uses pins 2, 3 and 5. Pins 2 and 3 must be crossed.

Run the OS3.x software and you will see the following screen:

If your text and color fields remain empty and the headline says „OFFLINE“, you must verify your serial settings and the DIL switch setting. To do this, select „Comms“ from the menu bar.



- Ex factory, all motrona units use the following serial standard settings: Unit No. 11, Baud rate 9600, 1 start/ 7 data/ parity even/ 1 stop bit
- If the serial settings of your unit should be unknown, you can run the „SCAN“ function from the „TOOLS“ menu to find out.

8. Displays and Softkeys

The edit window for all unit parameters can be found on the left side of the screen.

The INPUTS field shows the softkeys to switch the control commands on or off. Display boxes in the RS column indicate when the corresponding command is set to ON by PC. Display boxes in the PI/O column indicate that the corresponding command is ON by external hardware.

The boxes in the OUTPUTS field provide information about the state of the unit, where "Status A" and "Status B" are especially useful to check the counting inputs:

- Status A is lit when a counting pulse is detected on input A
- Status B is lit when a counting pulse is detected on input B
- For input modes using direction information, Status B is lit when the actual direction of the input corresponds to forward count in the positive sense.

The color bar graph displays the actual output state in a range of +/- 100 % of full scale.

Control keys are available for readout, transmission and storage of parameters.

9. Parameter Settings

Parameter	Description
Display Setting: x Operand / Operand +/- Operand	<p>These operands allow to convert the result to the desired engineering units. The conversion affects the numeric value for serial read out from register <:8> only, but not the scaling of the analogue output.</p> <p>With settings</p> $\frac{x \text{ operand}}{/ \text{ operand}} = 1.0000$ $\frac{x \text{ operand}}{/ \text{ operand}} = 1.0000$ $+/- \text{ operand} = 0.0000$ <p>the readout from register < :8 > equals to the percentage result (xxx.xxx%), where 100,000% has been defined by the TEACH minimum and TEACH maximum settings</p>

Readout from <:8>	=	Measuring result in % of full scale	x	$\frac{x \text{Operand}}{/ \text{Operand}}$	+	+/-Operand
-------------------	---	-------------------------------------	---	---	---	------------

General Setting Teach Minimum Teach Maximum	<p>This couple of settings define your minimum and maximum count for input A and input B (if applicable), where your analogue output moves from 0 V to 10 V.</p> <p>You can enter your minimum and maximum settings as follows:</p> <ul style="list-style-type: none"> • either by operating the Teach pushbutton (like described already under 5.1) • or by entering the counter settings directly by keyboard to the parameter field of your screen, without using the TEACH function.
--	--



When using summary or differential counting modes (A+B, A-B), these settings already refer to the sum or the difference of the counter.

Parameter	Description
Output Mode:	Selects the output format of the analogue outputs as shown:
	<div style="display: flex; justify-content: space-around;"> <div style="border: 1px solid gray; padding: 5px; width: 20%;"> <p>Output Mode = 0</p> <p>-10V ... 0 ... +10V</p> </div> <div style="border: 1px solid gray; padding: 5px; width: 20%;"> <p>Output Mode = 1</p> <p>0 ... +10V</p> </div> <div style="border: 1px solid gray; padding: 5px; width: 20%;"> <p>Output Mode = 2</p> <p>4 ... 20 mA</p> </div> <div style="border: 1px solid gray; padding: 5px; width: 20%;"> <p>Output Mode = 3</p> <p>0 ... 20 mA</p> </div> </div>
Linearization Mode:	<p>Sets the mode of linearization.</p> <p>0: Linearization off, registers P1 to P16 do not affect the output characteristics.</p> <p>1: Linearization in a range of 0 – 100%</p> <p>2: Linearization over full range –100% to +100%</p> <p><u>See example under section „Linearization“</u></p>
Factor A Factor B:	<p>Impulse scaling factors for the two counter inputs.</p> <p>Setting 1.0000 results in one increment with every input pulse, whereas setting 0.5000 would need 10 input pulses to increment by 5 etc.</p>
1/4 Edge Mode:	<p>This setting, with use of quadrature A/B input, allows simple count (x1) or full quadrature count (x4), by either accepting rising edges from input A only, or all rising and falling edges from inputs A and B</p> <p>0 = simple count (x1)</p> <p>1 = quadrature count (x4)</p>
AB Mode:	<p>Sets the counting mode with two independent single-channel inputs</p> <p>0 = no combination</p> <p>1 = sum A + B</p> <p>2 = difference A – B</p> <p>DIL switch positions 2 and 3 must be set correspondingly.</p>
Reset Mode:	<p>Sets the behavior of the Reset input:</p> <p>0 = static reset with “high” level</p> <p>1 = dynamic reset by rising edge *)</p> <p>2 = dynamic reset by falling edge *)</p> <p>3 = dynamic reset by rising edge **)</p> <p>4 = dynamic reset by falling edge **)</p> <p><u>Settings 1 and 3:</u></p> <p><u>Settings 2 and 4:</u></p>

*) The duration between the active edge and the zero state of the analogue output is 5 msec.
During this internal processing period the analogue output may make undefined jumps

**) The duration between the active edge and the zero state of the analogue output is 10 msec,
but there will be a defined zero approach with no jumps

Parameter	Description
Reset Value:	With every reset command, the counter presets to the datum set here (e.g. 000 000) and the analogue output follows the new counter state according to its output scaling.
Round Loop:	This register limits the counting range to a repeating loop. With setting of 1000, in upwards direction 999 is followed by to 000, and in downwards direction the counter sets to 1000 when reaching zero. Setting this register to 000 000 provides counting over the full range.
Power up Mode:	Sets the action of the counter upon power up: 0 = Loads the previous value from power down memory 1 = sets counter to zero
<u>Set-Up-Settings:</u>	
Analogue Offset:	Allows adjusting the analogue zero output in a range of approx. +/- 100mV (respectively +/- 200 µA) if necessary.
Analogue Gain:	Sets the maximum output swing of the analogue output. Setting of 1000 results in a 10 volts respectively 20 milliamps output swing.
Direction:	Can be used to invert the polarity of the analogue output signal when converting quadrature A/B input signals or A=impulse and B=direction. 0 = no inversion of the polarity 1 = inversion of the polarity

Parameter	Description																																												
RS232 / RS485 Setting: Unit Number:	<p>Especially with RS 485 applications it is necessary to attach a specific address to each unit, since up to 32 units can be connected to the same bus. You can choose any address number between 11 and 99. Factory setting = 11</p> <p>The address must <u>not</u> contain a "0" because these numbers are reserved for collective addressing.</p>																																												
Serial Baud Rate:	<table border="1"> <thead> <tr> <th>Setting</th> <th>Baud</th> </tr> </thead> <tbody> <tr> <td>0*</td> <td>9600</td> </tr> <tr> <td>1</td> <td>4800</td> </tr> <tr> <td>2</td> <td>2400</td> </tr> <tr> <td>3</td> <td>1200</td> </tr> <tr> <td>4</td> <td>600</td> </tr> <tr> <td>5</td> <td>19 200</td> </tr> <tr> <td>6</td> <td>38 00</td> </tr> </tbody> </table>	Setting	Baud	0*	9600	1	4800	2	2400	3	1200	4	600	5	19 200	6	38 00																												
	Setting	Baud																																											
	0*	9600																																											
	1	4800																																											
	2	2400																																											
	3	1200																																											
	4	600																																											
	5	19 200																																											
6	38 00																																												
* = Factory setting																																													
Serial Format:	<table border="1"> <thead> <tr> <th>Setting</th> <th>Data bits</th> <th>Parity</th> <th>Stop bits</th> </tr> </thead> <tbody> <tr> <td>0*</td> <td>7</td> <td>even</td> <td>1</td> </tr> <tr> <td>1</td> <td>7</td> <td>even</td> <td>2</td> </tr> <tr> <td>2</td> <td>7</td> <td>odd</td> <td>1</td> </tr> <tr> <td>3</td> <td>7</td> <td>odd</td> <td>2</td> </tr> <tr> <td>4</td> <td>7</td> <td>none</td> <td>1</td> </tr> <tr> <td>5</td> <td>7</td> <td>none</td> <td>2</td> </tr> <tr> <td>6</td> <td>8</td> <td>even</td> <td>1</td> </tr> <tr> <td>7</td> <td>8</td> <td>odd</td> <td>1</td> </tr> <tr> <td>8</td> <td>8</td> <td>none</td> <td>1</td> </tr> <tr> <td>9</td> <td>8</td> <td>none</td> <td>2</td> </tr> </tbody> </table>	Setting	Data bits	Parity	Stop bits	0*	7	even	1	1	7	even	2	2	7	odd	1	3	7	odd	2	4	7	none	1	5	7	none	2	6	8	even	1	7	8	odd	1	8	8	none	1	9	8	none	2
	Setting	Data bits	Parity	Stop bits																																									
	0*	7	even	1																																									
	1	7	even	2																																									
	2	7	odd	1																																									
	3	7	odd	2																																									
	4	7	none	1																																									
	5	7	none	2																																									
	6	8	even	1																																									
	7	8	odd	1																																									
	8	8	none	1																																									
9	8	none	2																																										
* = Factory setting																																													
Protocol Setting:	<p>The serial port of the unit can operate in either "PC-Mode" or in "Printer Mode". With "PC-Mode", the unit waits for a request string and responds with a corresponding data string. For details of the protocol see description "SERPRO". With "Printer Mode" the unit sends data without any request and under Timer control as described subsequently.</p>																																												



As soon as the unit receives a character, it automatically switches to PC Mode and operates according to protocol. When for a period of 20 sec. no character has been received, the unit switches automatically to "Printer Mode" and starts cyclic data transmission.

The following register settings control the automatic cyclic transmission of internal register values by serial interface to peripherals like printers or displays.

Parameter	Description																																									
Serial Protocol:	<p>This register selects the serial protocol for the cyclic transmission.</p> <p>When set to 0, the string starts with the serial address of the unit ("Unit Number"), followed by a space and the value of the register to be read out. The string ends with a "Line Feed" character and a "Carriage Return" character.</p> <p>When set to 1, the unit number is omitted and the string starts with the register value directly. This allows a little faster transmission because of the shorter transmission time.</p>																																									
	<table border="1"> <thead> <tr> <th colspan="2"></th> <th colspan="11">Unit No.</th> </tr> </thead> <tbody> <tr> <td>Serial Protocol = 0 :</td> <td></td> <td>1</td> <td>1</td> <td></td> <td>+/-</td> <td>X</td> <td>X</td> <td>X</td> <td>X</td> <td>X</td> <td>X</td> <td>LF</td> <td>CR</td> </tr> <tr> <td>Serial Protocol = 1 :</td> <td></td> <td></td> <td></td> <td></td> <td>+/-</td> <td>X</td> <td>X</td> <td>X</td> <td>X</td> <td>X</td> <td>X</td> <td>LF</td> <td>CR</td> </tr> </tbody> </table>			Unit No.											Serial Protocol = 0 :		1	1		+/-	X	X	X	X	X	X	LF	CR	Serial Protocol = 1 :					+/-	X	X	X	X	X	X	LF	CR
		Unit No.																																								
Serial Protocol = 0 :		1	1		+/-	X	X	X	X	X	X	LF	CR																													
Serial Protocol = 1 :					+/-	X	X	X	X	X	X	LF	CR																													
Serial Timer:	This register determines the cycle time in seconds for the cyclic transmission. E. g. with a setting of 0.100 the selected register value will be transmitted every 100 ms. The Accuracy of the timer is +/-500 µs.																																									
Register Code:	<p>Selects the register to be transmitted cyclically.</p> <p>Setting of 00 selects register code :0, setting of 01 selects register code :1 etc.</p>																																									
Backup Value:	Upon power down, this register stores the last actual count. When the unit is powered up again, the counter re-loads this register value, provided the storage function has been enabled by parameter "Power up".																																									

10. Free Programmable Linearization

This programmable feature allows the user to convert the linear counting process to a non-linear analogue output. There are 16 programmable interpolation points available, which can be set in any desired distance over the full conversion range. Between two coordinates, the unit uses linear interpolation. Therefore it is advisable to use more points in a range with strong curves and only a few points where the curvature is less.

To specify your desired linearization curve, you must first set the „Linearization Mode“ register to either 1 or 2.

Use registers **P1(x)** to **P16(x)** to specify the coordinates on the x-axis. These are the analogue output values that the unit normally would generate according to the actual count. The settings are in % of full scale.

Now enter the attached values to registers **P1(y)** to **P16(y)**. These are the values that the analogue output will generate instead of the x- values

Example: the value set to register P2(y) will substitute original value P2(x) etc.



- x-registers must use continuously increasing settings, i.e. P1(x) must have the lowest and P16(x) must have the highest setting
- All entries use a percentage format of xx.xxx% full scale. Setting 0.000% means zero output and setting 100.000% means full scale output.
- With Linearization Mode set to 1, it is a must to set P1(x) to 0% and P16(x) to 100%. Linearization is defined in the positive range only and the negative range will be a mirror image of the positive range with reference to zero.
- With Linearization Mode set to 2, it is a must to set P1(x) to -100% and P16(x) to +100%. This enables the user to set curves which are not symmetric to the zero position.

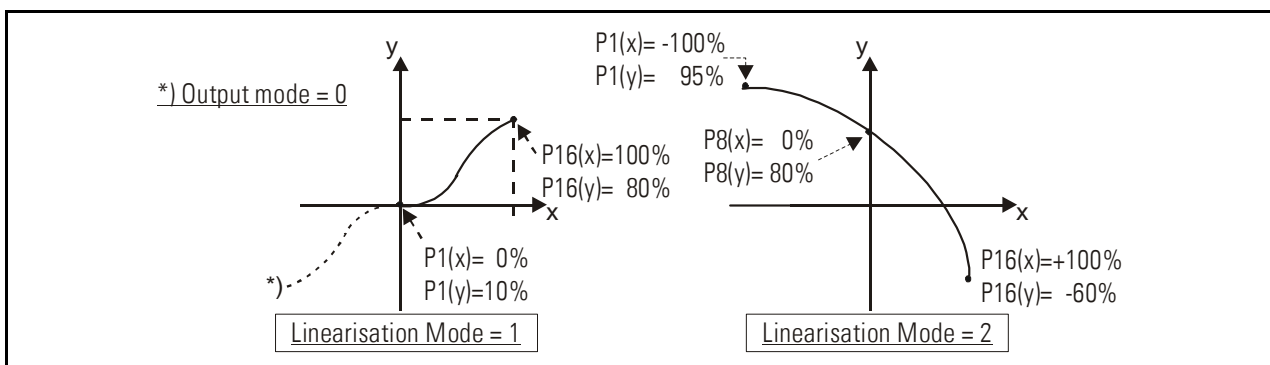

You can visualize your curve on the PC screen or by means of an external oscilloscope. For this, select TOOLS, then TEST and there „Analogue Voltage Function“. The unit will now simulate a repeating counting cycle over the full range and generate the analogue signal accordingly. When you use the Scope function of the operator software, you must set the serial code „:1 “ to record the analogue output.

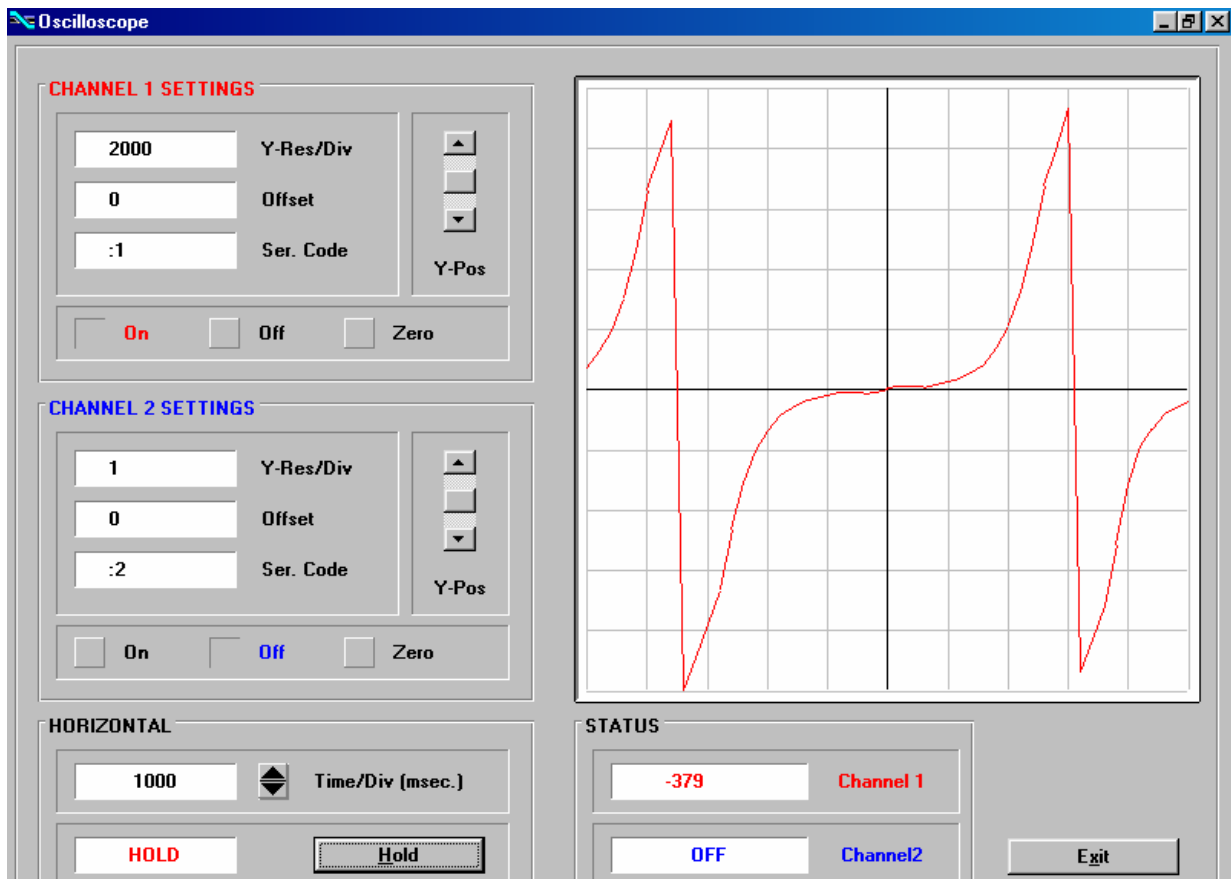

11. Test Functions

When you select TEST from the TOOLS menu, you are able to verify the following data, by clicking to the corresponding field:

- Actual counter value
- DIL switch settings
- Internal supply voltages
- Analogue output state

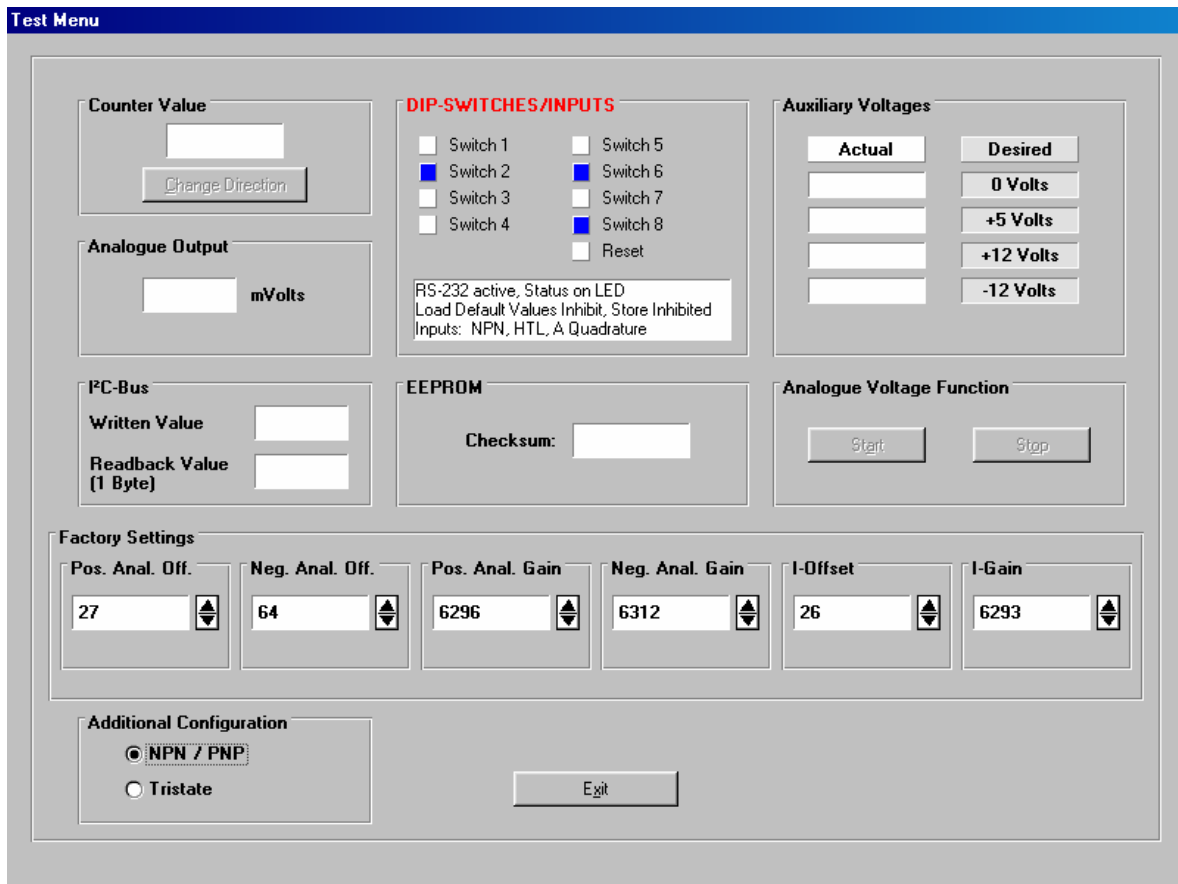

12. Dimensions

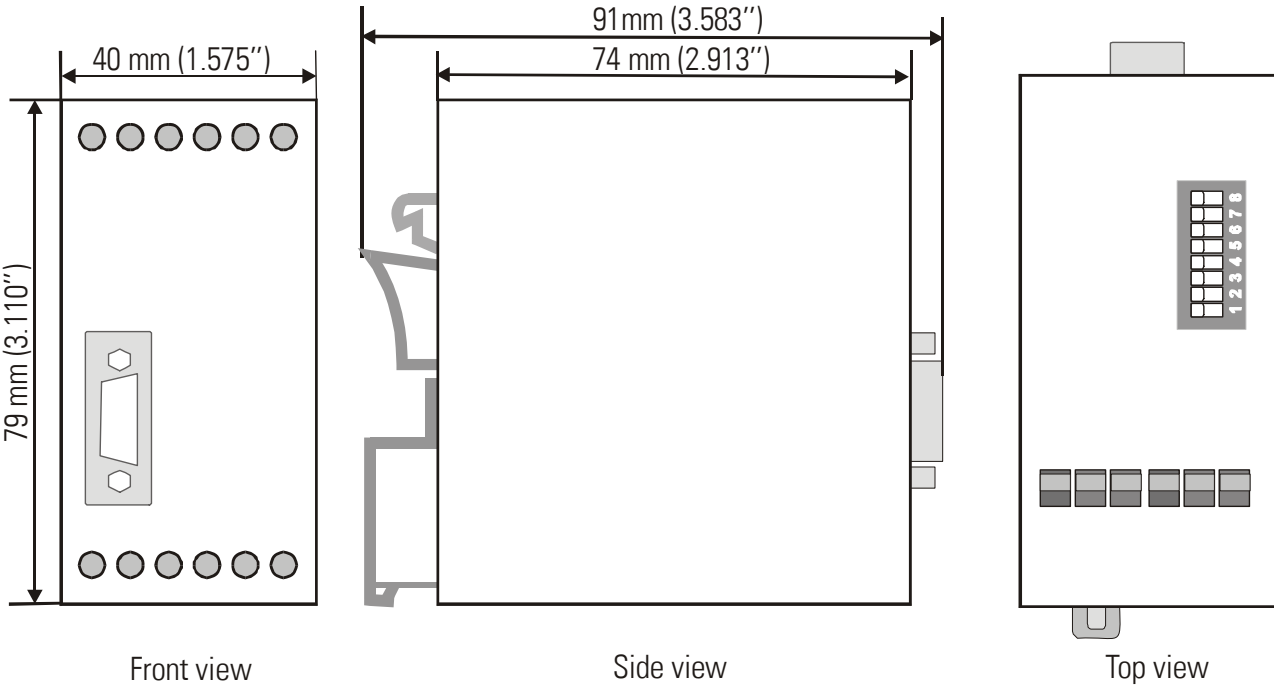

13. Technical Specifications

Power Supply	:	18...30 VDC
Power consumption	:	approx. 170 mA at 18 V approx. 120 mA at 30 V (+5.5V uncharged)
Encoder supply	:	+5.5V +/- 5% (max. load: 150mA)
Inputs RS422 and TTL	:	TTL differential, RS 422 standard
Inputs HTL and Reset	:	High > 10 V, Low < 3 V
Analogue outputs	:	+/- 10 V (> 5 kOhm) 0-20 mA / 4-20 mA (< 270 Ohm)
Step width of analogue outputs	:	1.25 mV / 2.5 µA
Analogue resolution	:	14 bits (+ 10V / +20mA ... -10V/ -20mA)
Accuracy of analogue output	:	0.1% +/- 1 digit
Response time counter => analogue (normal operation):	:	approx. 1 msec
Reset time of the analogue output upon external reset command	:	approx. 5 msec or 10 msec (see "Reset Mode")
Minimum Reset pulse duration	:	5 msec
Temperature range	:	Operation: 0° ... +45°C (+32 ... +113°F) Storage: -25° ... +70°C (-13 ... +158 °F)
Weight	:	approx. 190 g
Conformity and standards	:	EMC 89/336/EEC: EN 61000-6-2 EN 61000-6-3 LV73/23/EEC: EN 61010-1

14. Parameter List

Parameter	Min. value	Max. value	Default	Digits	Decimal positions	Serial Code
*Operand	-99 999	99 999	10 000	+/- 5	4	00
/Operand	1	99 999	10 000	5	4	01
+/- Operand	-100 000 000	100 000 000	0	+/- 9	0	02
Teach Minimum A	-100 000 000	100 000 000	0	+/- 9	0	03
Teach Maximum A	-100 000 000	100 000 000	10 000	+/- 9	0	04
Factor A	1	99 999	10 000	5	4	05
Factor B	1	99 999	10 000	5	4	06
Output Mode	0	3	0	1	0	07
Linearization Mode	0	2	0	1	0	08
¼ Edge Mode	0	1	0	1	0	09
AB Mode	0	2	0	1	0	10
Reset Mode	0	4	0	1	0	11
Reset Value	-100.000 000	100 000 000	0	+/- 9	0	12
Round Loop	0	1 000 000	0	7	0	13
Power up Mode	0	1	0	1		14
P1 (x)	-100 000	100 000	100 000	+/- 6	3	A0
P1 (y)	-100 000	100 000	100 000	+/- 6	3	A1
P2 (x)	-100 000	100 000	100 000	+/- 6	3	A2
P2 (y)...	-100 000	100 000	100 000	+/- 6	3	A3...(A9)...(B0)
P16 (x)	-100 000	100 000	100 000	+/- 6	3	D0
P16 (y)	-100 000	100 000	100 000	+/- 6	3	D1
Direction	0	1	0	1	0	46
Analog Offset	-99	99	0	+/- 2	0	47
Analog Gain	0	10 000	1 000	5	0	48
Unit Number	0	99	11	2	0	90
Serial Rate	0	6	0	1	0	91
Serial Format	0	9	0	1	0	92
Serial Protocol	0	1	0	1	0	30
Serial Timer	5	99 999	100	5	3	31
Register Code	0	19	0	2	0	32
Backup Encoder A	-100 000 000	+100 000 000	0	+/- 9	0	33
Backup Encoder B	-100 000 000	+100 000 000	0	+/- 9	0	34
Backup Rest A	-10 000	+10 000	0	+/- 5	0	35
Backup Rest B	-10 000	+10 000	0	+/- 5	0	36