

GV 210

Cross Switcher and Splitter for Incremental Encoder Signals

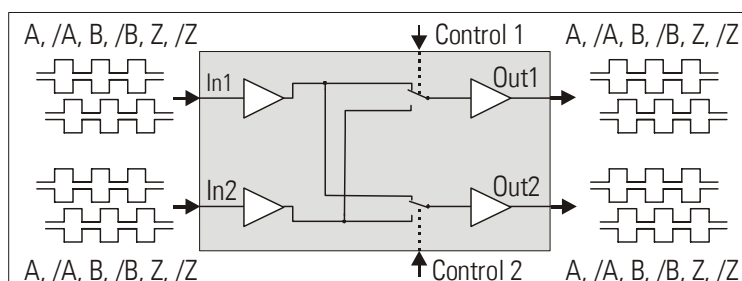

- Universal encoder interface, applicable as level converter, encoder splitter and encoder cross switch
- Two encoder inputs A, B, Z and /A, /B, /Z, adjustable to either TTL/RS422 level or to HTL (10-30 volts) level
- Two signal outputs A, B, Z and /A, /B, /Z, likewise adjustable to either TTL/RS422 or HTL (10-30 volts) level
- High frequency range (1 MHz)
- Contactless and bounce-free switch-over between the encoder channels, by remote control signals
- Power supply 12-30 volts DC, auxiliary output 5 volts for encoder supply

Operating Instructions



Safety Instructions

- This manual is an essential part of the unit and contains important hints about function, correct handling and commissioning. Non-observance can result in damage to the unit or the machine, or even in injury to persons using the equipment !
- The unit must only be installed, connected and activated by a qualified electrician
- It is a must to observe all general and also all country-specific and application-specific safety standards
- When this unit is used with applications where failure or maloperation could cause damage to a machine or hazard to the operating staff, it is indispensable to meet effective precautions in order to avoid such consequences
- Regarding installation, wiring, environmental conditions, screening of cables and earthing, you must follow the general standards of industrial automation industry
- - Errors and omissions excepted –

Version:	Description:
GV21001b/ Feb.05 /af/hk	Original version released
GV21001c/ Jul. 05 /hk	Terminal assignments and coding (X1 – X5)
GV21001d/ Aug.05 /hk	Clarification RS422 /differential and HTL /single-ended operation
GV21001e/ Jul.07 /hk	Corrections TTL-single-ended, outlines and dimensions
GV21002a/ Feb 08 /hk	New version, 1 MHz, DIL switch for TTL single-ended

Table of Contents

1. Applications	4
1.1. Dual level converter	4
1.2. Encoder splitter (dual output).....	4
1.3. Encoder signal switcher	5
2. Connection Diagram	6
2.1. Power supply	6
2.2. Control inputs	6
2.3. Encoder inputs.....	6
2.4. Asymmetric TTL Inputs.....	7
2.5. Outputs	7
3. The Front LEDs	8
4. Switch Settings	9
5. Dimensions	10
6. Technical Specifications	11

1. Applications

1.1. Dual level converter

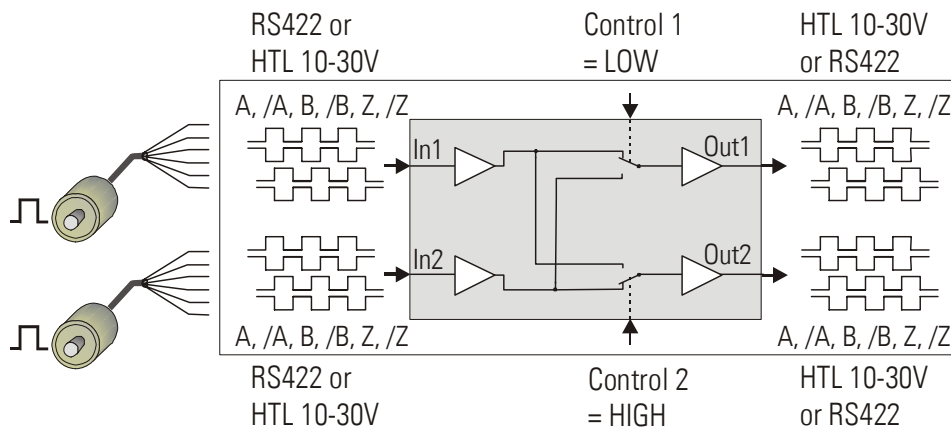

Both inputs can be individually set to either symmetric (differential) format using A, /A, B, /B, Z, /Z channels, or to asymmetric (single-ended) format using A, B, Z channels only. Acceptable input levels are RS422, TTL and HTL 10-30 volts.

The output format can again be selected individually for each output.

The outputs provide always all signals including the inverted channels, even when no inverted signals are applied to the input.

With Control input 1 = LOW (or unconnected) and Control input 2 = HIGH the signal ways are as shown in the drawing above, featuring two independent level converters.

1.2. Encoder splitter (dual output)

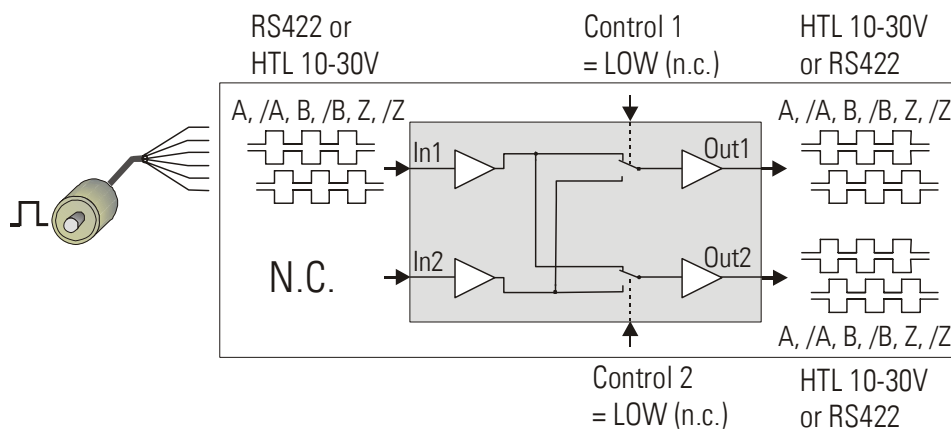

Input 1 is used as encoder input, and Input 2 remains unconnected. The input can be set to either symmetric (differential) format using A, /A, B, /B, Z, /Z channels, or to asymmetric (single-ended) format using A, B, Z channels only.

Acceptable input levels are RS422, TTL and HTL 10-30 volts.

The output standard can again be selected individually for each output. The outputs provide always all signals including the inverted channels, even when no inverted signals are applied to the input. Control1 and Control2 remain unconnected with this application.

1.3. Encoder signal switcher

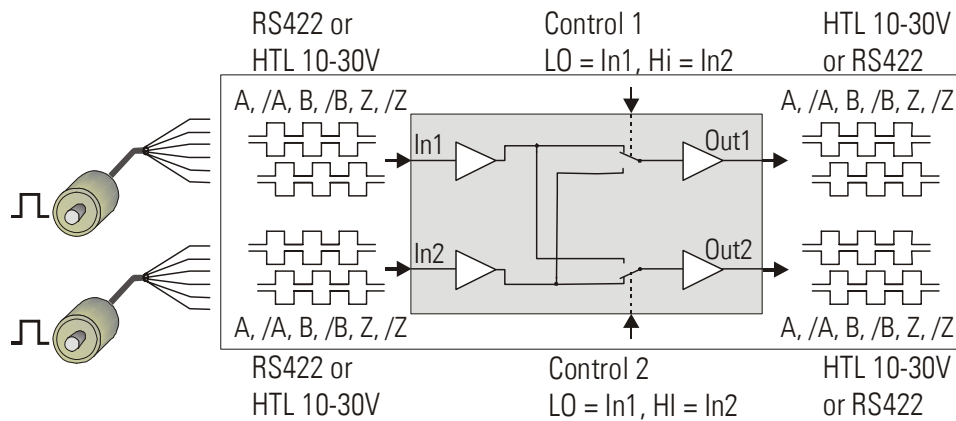

Both inputs can be individually set to either symmetric (differential) format using A, /A, B, /B, Z, /Z channels, or to asymmetric (single-ended) format using A, B, Z channels only. Acceptable input levels are RS422, TTL and HTL 10-30 volts.

The output standard can again be selected individually for each output.

The outputs provide always all signals including the inverted channels, even when no inverted signals are applied to the input.

Inputs Control1 and Control2 select the signal ways:

LOW: The corresponding output is connected to input 1

HIGH: The corresponding output is connected to input 2

2. Connection Diagram

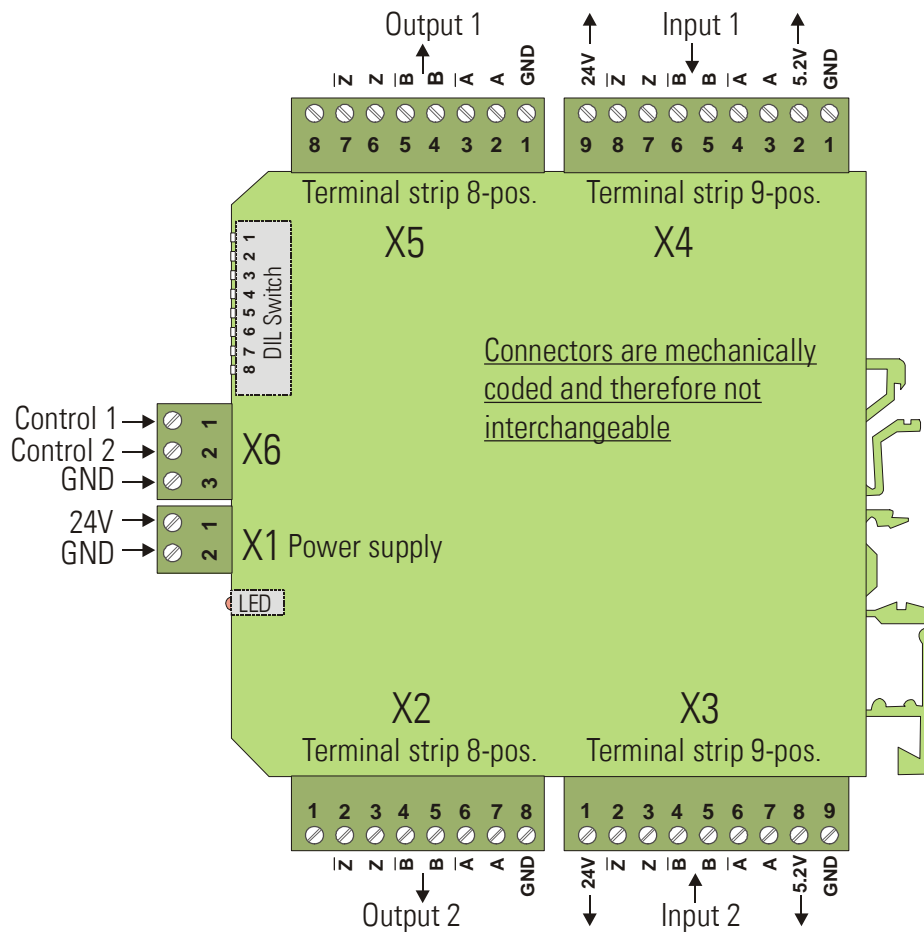

2.1. Power supply

The unit requires a 12–30 volts DC power supply via the 2-position power terminal on the front side (terminal 1 = +, terminal 2 = GND)

The current consumption is about 50 mA (aux. voltages and outputs unloaded)

2.2. Control inputs

The control inputs are accessible via the 3-position terminal strip on the front. They are in LOW state when unconnected. To switch the inputs to HIGH state, a signal from +10 to +30 volts must be applied to the corresponding terminal.

2.3. Encoder inputs

The input lines can be configured for different requirements by DIL switch setting. The following input formats can be used:

- Single-ended signals (asymmetric), channels A, B and Z only without inverted inputs (Level is HTL 10–30 volts in general, exceptionally also TTL, see 2.4)
- Differential signals (symmetric), channels A, /A, B, /B, Z, /Z (levels either according to RS422 standard or TTL or HTL 10-30 volts)

A, B and Z may at any time also be independent single signals, e.g. from proximities, photocells etc. Since the level of every channel is selected individually (see DIL-switch), it is possible to use different levels on the inputs. Consequently it is e.g. possible to take the position information from the A, /A, B and /B channels of a RS422 encoder, but to add the corresponding Z index pulse as a HTL signal from a remote photocell

With HTL signals, the switching threshold lies between 6.5 and 8 volts. The input uses an internal pull-down resistor of 5kOhms.

Every of the two input terminals provides two auxiliary voltage outputs for easy encoder supply: +5.2 volts/125 mA and +24 volts*/125 mA

*) Output = power supply voltage – 2 volts

2.4. Asymmetric TTL Inputs

Only when exceptionally asymmetric TTL input signals must be processed (i.e. TTL signals without inverted signal), a 2-position DIL switch located behind the front plate must be set. This hidden switch becomes accessible by slightly lifting up the front foil at the lower end (e.g. by means of a small screw driver)

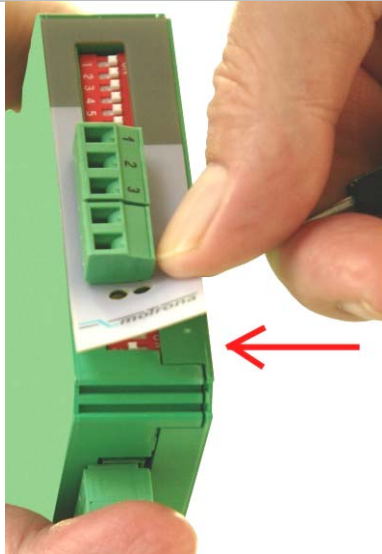

Switch position 1 is responsible for all channels of Input 1
Switch position 2 is responsible for all channels of Input 2
OFF = Asymmetric operation with HTL level (10 – 30 V)
ON = Asymmetric operation with TTL-Pegel

 Ex factory both switches are OFF, i.e. any single-ended operation requires HTL levels (this is the normal case)

 Asymmetric TTL levels are most sensitive to noise and interference, therefore not suitable for cable transmission in an industrial environment!

For all general applications please do not touch the DIL switch hidden behind the front plate !

2.5. Outputs

The outputs provide push-pull characteristics. When set to TTL/RS422 level, the corresponding output swing is always 5 volts. When set to HTL, the output swing depends on the power supply input (12 – 30volts).

All outputs are short-circuit-proof.

At any time the signal and the appropriate inverted signal are both available at the output, even when no inverted signal is applied to the input.

3. The Front LEDs

The green LED is lit as soon as a power supply voltage is applied to the unit.

The yellow LED indicates the state of the Control inputs and the basic function of the unit:

Yellow LED off: Control1 and Control2 are either both LOW or both HIGH at the same time. In this case the unit operates as a splitter (both outputs are connected to the same input)

Yellow LED on: Control1 and Control2 have different states. In this case the unit operates as a dual level converter or as a switcher (the outputs are connected to different inputs)

4. Switch Settings

The DIL switch sets level and standard of inputs and outputs:

0=OFF 1=ON								DIL switch settings	
8	7	6	5	4	3	2	1		
							0	Output 1: TTL / RS422	The output levels are 5 volts with TTL setting and correspond to the power supply voltage with HTL setting
							1	Output 1: HTL	
						0	Output 2: TTL / RS422		
						1	Output 2: HTL		
			0 (Z)	0 (B)	0 (A)			Input 1: differential (A, /A, B, /B, Z, /Z)	Both, input and inverted input must be used. Levels from 2 to 30 volts are acceptable.
			1 (Z)	1 (B)	1 (A)			Input 1: single-ended (A,B,Z) with HTL level *)	Inverted inputs remain open, level must be HTL 10-30 volts
0 (Z)	0 (B)	0 (A)						Input 2: differential (A, /A, B, /B, Z, /Z)	Both, input and inverted input must be used. Levels from 2 to 30 volts are acceptable.
1 (Z)	1 (B)	1 (A)						Input 2: single-ended (A,B,Z) with HTL level *)	Inverted inputs remain open, level must be HTL 10-30 volts

*) This setting can also be used with asymmetric (single-ended) TTL levels. See 2.4



Please set unused input lines to "single-ended" HTL at any time!

It is not mandatory to use the same level for all channels of an input. The indications (A), (B), (Z) show which switch position is responsible for which channel.

When e.g. positions 3 and 4 are set to "0" and position 5 is set to "1", Input1 would accept A, /A, B, /B at RS422 standard, and the Z index as a HTL single-ended signal.

Consequently it is possible to e.g. generate an Index from a remote photocell, whereas the impulses come from the RS422 encoder simulation of a drive system.

5. Dimensions

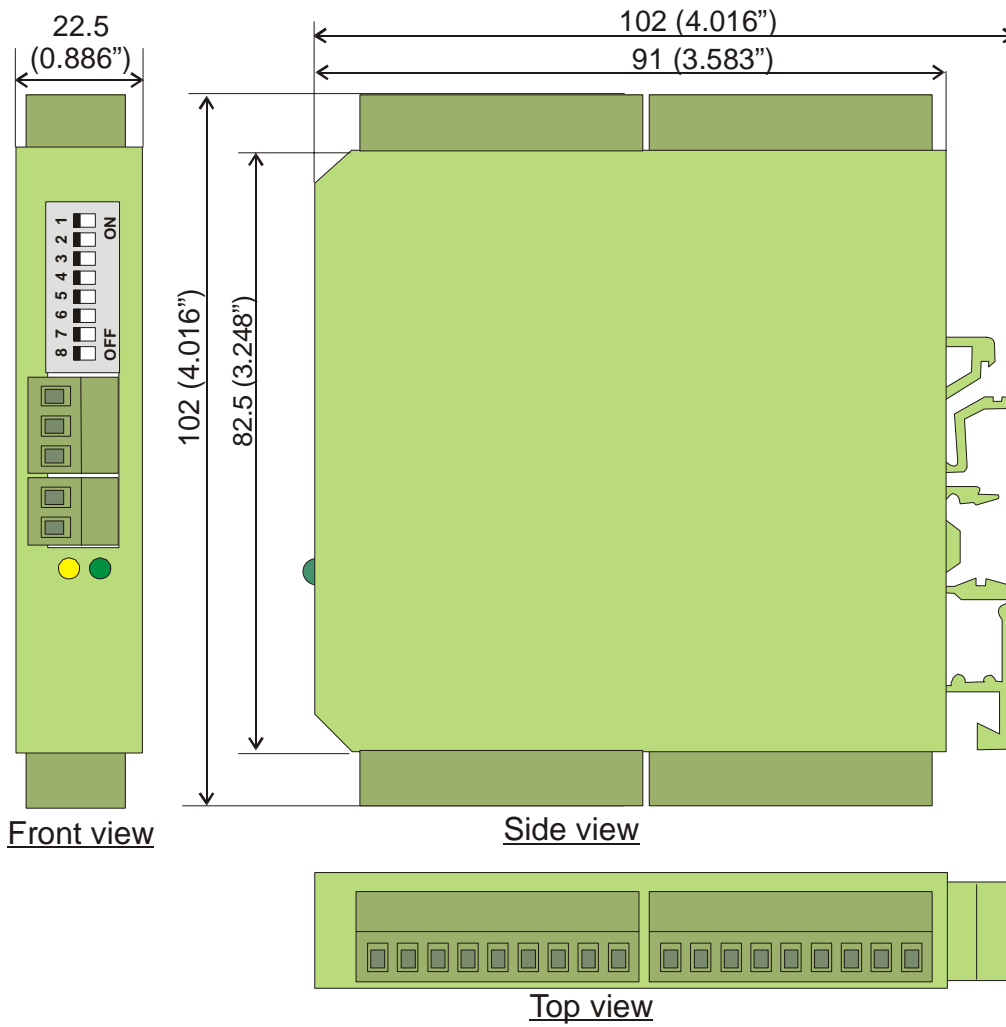

6. Technical Specifications

Power supply V_{in}	:	12 - 30 Vdc
Power consumption	:	50 mA (no-load operation)
Aux. encoder supply output	:	5.2 volts and $V_{in} - 2$ volts, 2x 125 mA (short-circuit-proof)
Max. frequency	:	1 MHz (RS422 or TTL differential) 250 kHz (HTL and TTL single-ended)
Inputs	:	Single-ended A, B, Z (2x) or differential A, /A, B, /B, Z, /Z (2x), 2 – 30 volts
Outputs	:	Push-pull A, /A, B, /B, Z, /Z (2x) Level 5 – 30 volts, 30 mA (short-circuit-proof)
Signal propagation delay	:	approx. 600 nsec.
Ambient temperature	:	Operation: 0° - 45° (32 - 113 °F) Storage: -25° - +70° (-13 - 158 °F)
Weight	:	ca. 100 g
Conformity and standards	:	EMC 89/336/EEC: EN 61000-6-2 EN 61000-6-3 LV73/23/EEC: EN 61010-1