

GV150 / GV151

Impulse Amplifier and Splitter for Encoder Signals



- Impulse input (A, /A, B, /B, Z, /Z, TTL level or HTL level)
- Potential separation by high speed opto-couplers
- 6 output channels, each (A, /A, B, /B, Z, /Z)
GV150: all outputs TTL / RS422
GV151 outputs individually programmable to either TTL or HTL level
- Frequency range 0 - 400 kHz
- Front LED's for indication of input pulses A, B and Z
- Elimination of noise and cross talking on transmission lines
- Closed aluminum cassette for mounting in 19"racks or assembly on DIN mounting rails

Operating Instructions



Safety Instructions

- This manual is an essential part of the unit and contains important hints about function, correct handling and commissioning. Non-observance can result in damage to the unit or the machine or even in injury to persons using the equipment!
- The unit must only be installed, connected and activated by a qualified electrician
- It is a must to observe all general and also all country-specific and application-specific safety standards
- When this unit is used with applications where failure or maloperation could cause damage to a machine or hazard to the operating staff, it is indispensable to meet effective precautions in order to avoid such consequences
- Regarding installation, wiring, environmental conditions, screening of cables and earthing, you must follow the general standards of industrial automation industry
- - Errors and omissions excepted –

Version:	Description:
GV15002B/hk_03/2008	First motrona edition with A5 brochure format

Table of Contents

1. Application and Construction.....	4
2. Connections, Switch Settings.....	5
3. Block Diagram.....	6
4. Input Pin Assignment.....	7
5. Output pin assignment.....	7
6. Technical Data	8

1. Application and Construction

The unit is used to increase the drive capability of existing encoder signals and to distribute the signals to several channels. At the same time it provides potential separation between source and target lines as well as level conversion.

In general, an incremental encoder output is limited to drive currents of 20 mA only on its impulse lines. The GV150 amplifiers increase the Fan-Out to 6 channels, each loadable with 20 respectively. 30 mA per line. The units can be used for encoder pulse transmission and for data transmission applications as well.

As a standard, GV150 and GV151 provide TTL (RS422) inputs (A, /A, B, /B, Z, /Z)

With Option **HTLIN1**, the input is set to HTL level (12...30V), and only the signals A, B and Z necessary (no inverted signals).

With option **HTLIN2**, the input is also set to HTL level (12...30V), but all signals must be applied (A, /A, B, /B, Z, /Z).

Each of the 6 output channels generates the signals (A, /A, B, /B, Z, /Z) .

GV150 provides **always TTL/ RS422** standard and

GV151 has individually programmable output levels **TTL or HTL**

2. Connections, Switch Settings

- The unit is supplied by a power connector on the front side.
The power supply range is 18 - 30 VDC.
- For operation without potential separation, positions 3 and 4 of the internal DIL switch S1 can be set to "ON". This will connect the input GND to the output GND and to the Minus potential of the power supply
- Pin 4 of the input connector provides an auxiliary voltage output, when the DIL-switch positions 1 and 2 are set to "ON".



When DIL-switch positions 1 and 2 are set to "ON", never any external voltage must be applied to pin 4!

The aux. output voltage is 5,5V/ 300mA with TTL inputs and 24V/ 300mA with options HTLIN1 and HTLIN2.

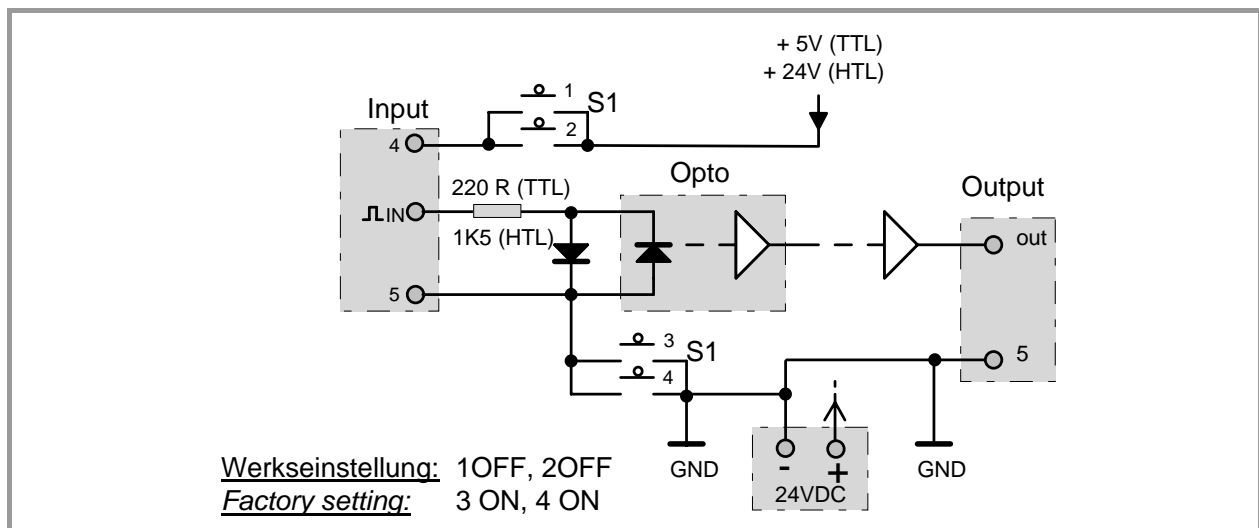

All DIL switches become accessible when you remove the right hand side plate.

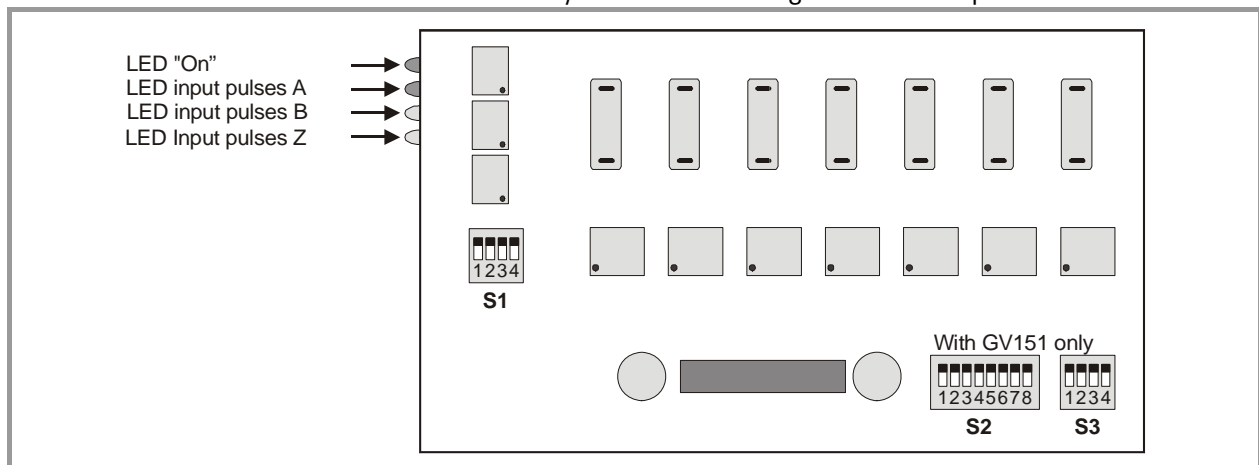

3. Block Diagram

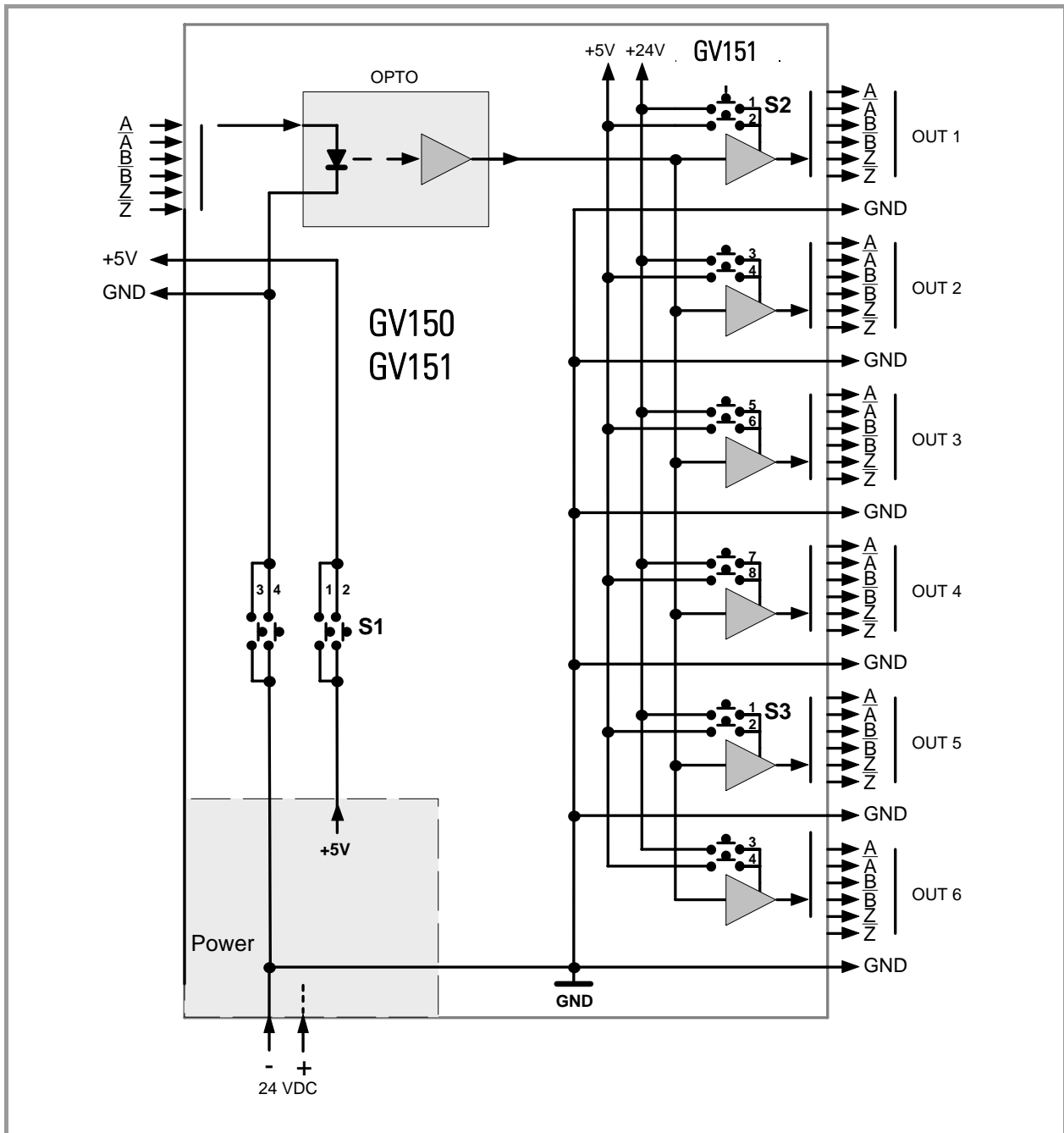

4. Input Pin Assignment

(Sub-D-9 male on the unit) * See DIL switch S1

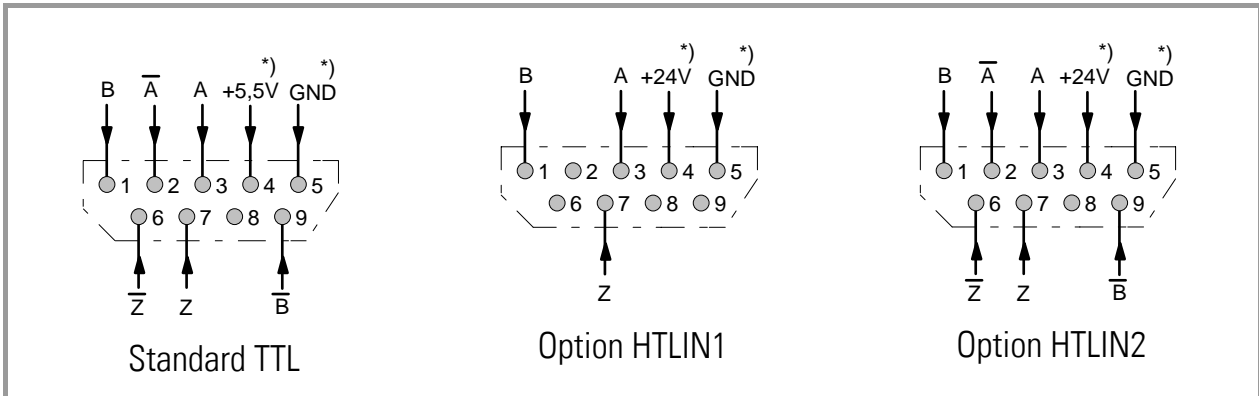

5. Output pin assignment

(Sub-D-9 female on the unit)

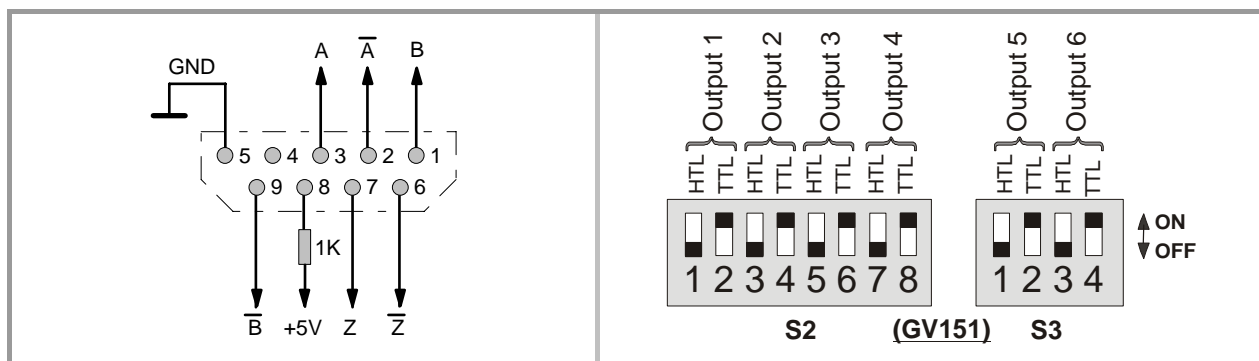

With GV151, you can select the desired output level (TTL/HTL) by setting the associated position of the DIL switch to „ON“ (with the other position OFF).

Setting both TTL and HTL to ON at a time would result in HTL output.

For safety reasons, the default factory setting is always TTL like shown above.

