

FU 252

Signal Converter Frequency-to-Analogue and Frequency-to-Serial



- Input frequency range from 0.1 Hz to 1 MHz for full scale analogue output
- Conversion time only 1 msec. ($f > 3$ kHz)
- Analogue outputs +/- 10 V, 0 - 20 mA and 4 - 20 mA
- Polarity of analogue signal changes with change of the direction of rotation
- Suitable for conversion of quadrature signals (A/B) as well as single-channel signals, with all HTL or TTL or RS422 formats and levels
- Suitable for conversion of the sum, the difference or the ratio of two frequencies
- RS 232 and RS 485 interfaces for serial readout of the input frequencies
- Programmable digital filters and programmable linearisation curves
- Easy to set up by simple TEACH procedure, or by PC operator software

Operating Instructions



Safety Instructions

- This manual is an essential part of the unit and contains important hints about function, correct handling and commissioning. Non-observance can result in damage to the unit or the machine or even in injury to persons using the equipment!
- The unit must only be installed, connected and activated by a qualified electrician
- It is a must to observe all general and also all country-specific and application-specific safety standards
- When this unit is used with applications where failure or maloperation could cause damage to a machine or hazard to the operating staff, it is indispensable to meet effective precautions in order to avoid such consequences
- Regarding installation, wiring, environmental conditions, screening of cables and earthing, you must follow the general standards of industrial automation industry
- - Errors and omissions excepted –

Version:	Description:
FU25201a_af_hk_04/2007	First edition

Table of Contents

1.	Compatibility Hint	4
2.	Introduction	5
2.1.	Impulse input formats and input levels.....	5
2.2.	Operating range.....	6
2.3.	Suitable encoders and sensors	6
3.	Terminal Assignments and Connections.....	7
3.1.	Example for use of TTL encoders	7
3.2.	Example for use of HTL encoders.....	8
3.3.	Proximity switches, photocells etc.....	8
3.4.	Analogue outputs	8
3.5.	Serial interface.....	9
4.	DIL Switch Settings.....	10
4.1.	Basic mode of operation	10
4.2.	Impulse levels and symmetric / asymmetric input formats	11
4.3.	Analogue output format	12
4.4.	Selecting the RS232 or the RS485 serial interface	13
4.5.	Teach function, Test function, Loading of default settings	13
5.	Commissioning.....	14
5.1.	Conversion of one only frequency (single channel or dual channel with direction signal).....	15
5.2.	Conversion and combination of two independent frequencies (A + B, A - B, A x B, A : B).....	15
6.	PC Setup with Use of the Operator Software OS3.x.....	16
7.	Parameter Description	18
8.	Free Programmable Linearisation	25
9.	Monitor Functions	27
10.	Data Readout via Serial Interface.....	29
11.	Dimensions	30
12.	Specifications	31
13.	Internal Registers and Serial Codes.....	32

1. Compatibility Hint

This product is a successor model of the thousandfold approved converter type FU251. The new product is suitable for a 100% replacement of the previous model, however some differences must be observed with DIL switch settings and parameter settings.

Some essential advantages of FU252 compared to FU251 are:

- **Maximum frequency 1 MHz (instead of 500 kHz)**
- **Total conversion time in-out = 1 msec (this was no more assured with FU251 after the modifications necessary for RoHS conformity)**
- **Capability to accept even single-ended TTL input signals (i.e. TTL input A only without inverted TTL signal /A)**
- **Setting of analogue formats +/-10V, +10V, 0-20 mA and 4-20 mA can be done by supplementary DIL switch (no more PC required)**
- **Enhanced auxiliary output 5 V / 250 mA for encoder supply**

2. Introduction

FU 252 is a small and low-cost, but highly performing converter for industrial applications, where one frequency or two different frequencies need to be converted into an analogue signal or a serial data format. The unit has been designed as a compact module with 12 screw terminals and a 9-position SUB-D connector (female). The housing is suitable for standard DIN rail mounting.

2.1. Impulse input formats and input levels

The input site provides channels A and B and also the inverted lines /A and /B. All inputs are designed for use with either HTL level or TTL level, with either single-ended format or differential format (RS422).

The unit can convert the following formats to analogue and serial:

- Quadrature signals with a 90° phase displacement. Polarity of the analogue output and sign of the serial data depend on the direction given by the A/B phase.
- Single channel impulses on channel A. Input B sets the polarity of the output (LOW = negative, HIGH = positive). In case of open (unconnected) inputs, please note:
 - Open NPN inputs are evaluated as HIGH state
 - Open PNP inputs are evaluated as LOW stateOpen RS422 inputs may cause problems, therefore please set unused inputs to HTL by means of the appropriate DIL switch
- Fully independent frequencies on both channels A and B. The output signal can represent the sum, the difference, the product or the ratio of the two input frequencies.

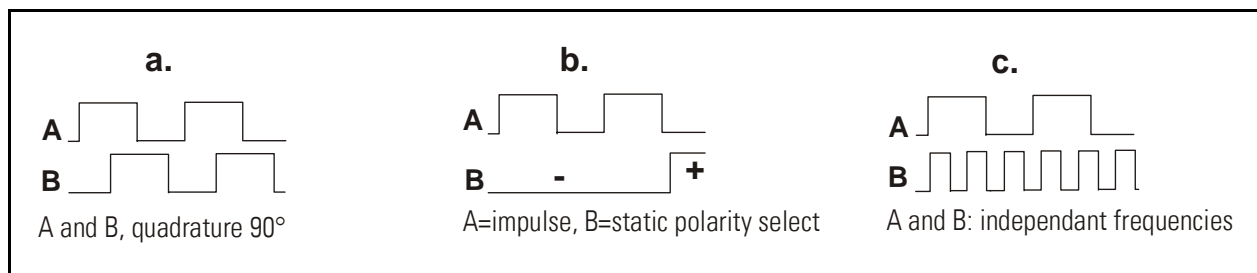

2.2. Operating range

The full scale frequency (i.e. the input frequency where the analogue output reaches 10 V or 20 mA) can be set in a range from -1 MHz to $+1$ MHz. The operating range of the unit can be assigned to any frequency window inside this frequency range.

A "zero output frequency" can be set to guarantee defined operation of the converter with low input frequencies.

For applications with unstable input frequencies, the unit provides programmable digital filters for smoothing of the output signal.

2.3. Suitable encoders and sensors

The FU252 converter can accept the following impulse sources:

- Quadrature encoders with HTL level output (10 – 30 V) and either PNP or NPN or Push-Pull or NAMUR characteristics, using A and B outputs with 90° displacement
- Single channel impulse sources like proximity switches or photocells, providing HTL level at PNP or NPN or Namur characteristics
- TTL / RS422 quadrature encoders with output lines A, /A, B and /B
- Symmetric single channel sources with TTL / RS422 output, providing differential signals (e.g. A and /A)
- Asymmetric single channel sources with TTL level (without inverted signals, e.g. A only)

In general, HTL encoders will be supplied from the same source as the converter itself.

For supply of TTL encoders, the unit provides an auxiliary output of 5.5 volts (stabilized, max. 250 mA).

3. Terminal Assignments and Connections

We recommend connecting the Minus wire of the power supply to earth potential. Please observe that, under poor earthing and grounding conditions, multiple earth connections of screens and GND terminals may cause severe problems. In such cases it may be better to have only one central earthing point for the whole system.

GND terminals 4, 6 and 12 are connected internally.

Under nominal conditions the current consumption of the unit is approx. 70 mA (aux. output unloaded, see technical specifications) Lower input voltage and load of the aux. output will increase the consumption accordingly.

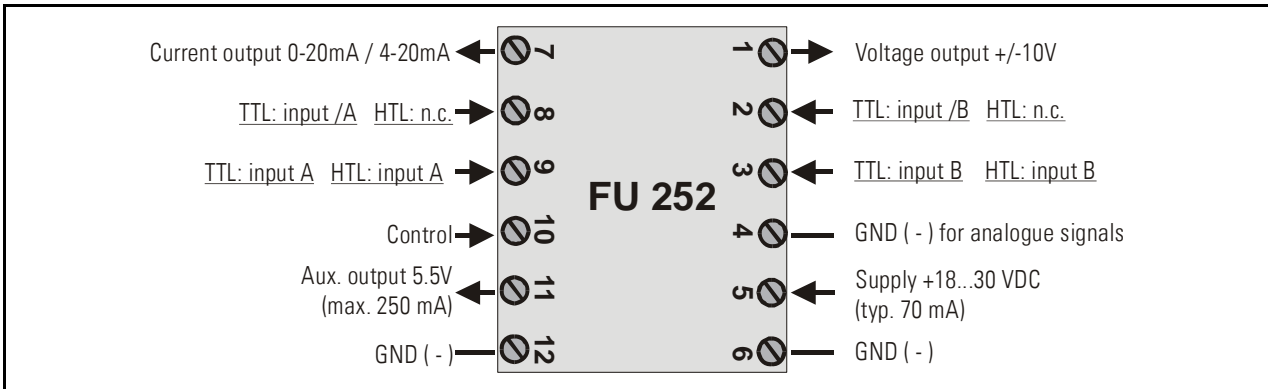

3.1. Example for use of TTL encoders

If applicable, the encoder can be supplied from the FU252 converter. Where the encoder is already supplied from a remote source, we recommend fully differential operation, with no GND connection between encoder and converter (see figures a. and b.)

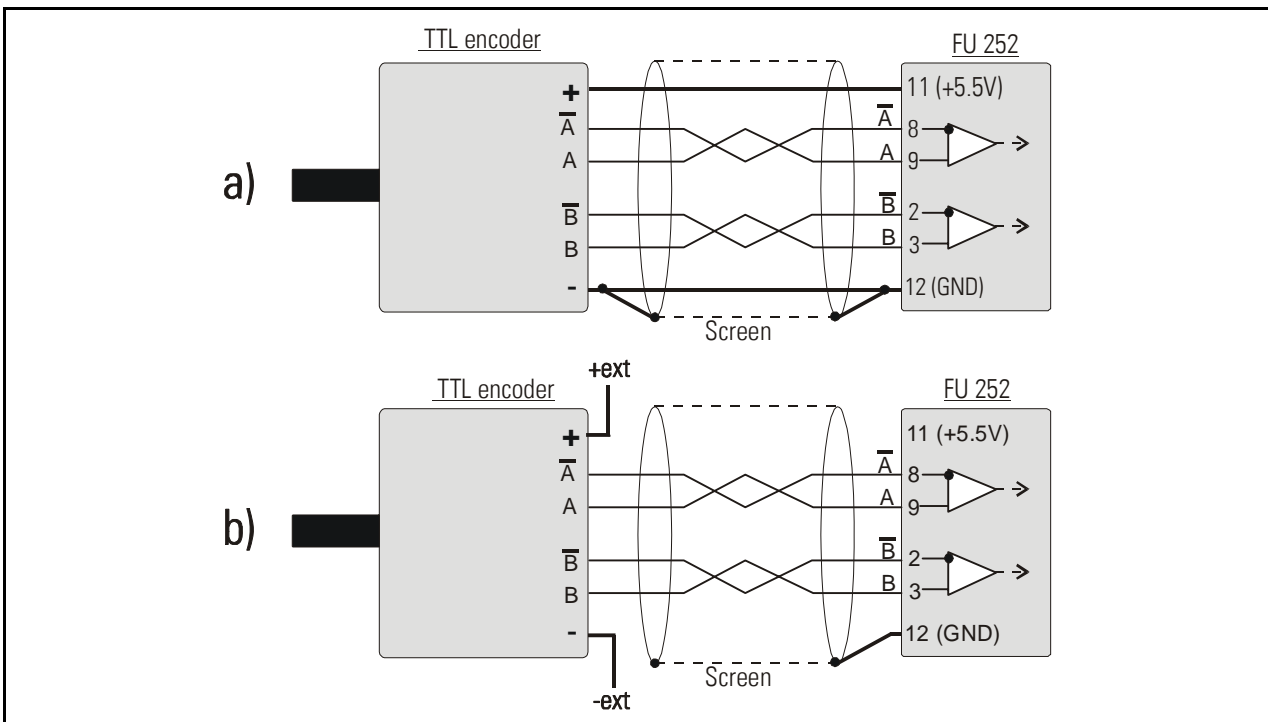

3.2. Example for use of HTL encoders

The encoder may be supplied from the same source as the converter, or from another source.

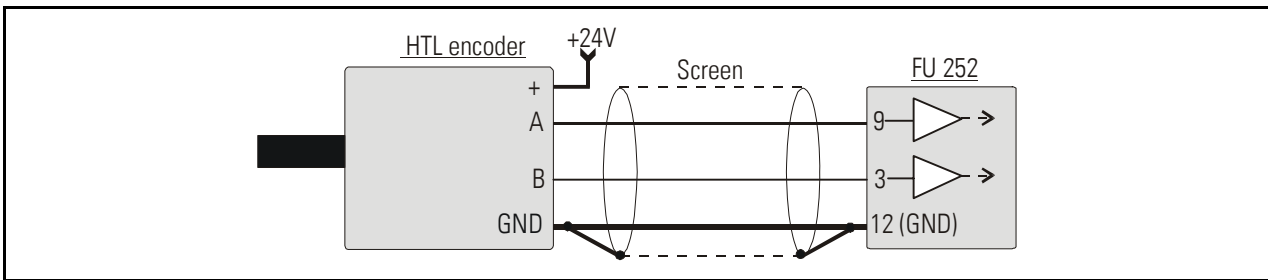

3.3. Proximity switches, photocells etc.

These connections are fully similar to a HTL incremental encoder. With single channel operation, input B remains unconnected or can be used to select the output polarity. With use of two independent frequencies for forming sum, difference or ratio, input B is used for the second input frequency.

To use sensors with 2-wire **NAMUR** characteristics:

- set the inputs to HTL and NPN
- connect the positive wire of the sensor to the corresponding input and the negative wire to GND.

3.4. Analogue outputs

The unit provides a $\pm 10\text{V}$ voltage output and a $0 - 20\text{mA} / 4 - 20\text{mA}$ current output at a resolution of 14 bits, i.e. the voltage output operates in steps of 1.25 mV and the current output operates in steps of $2.5\ \mu\text{A}$.

The nominal load of the voltage output is 2 mA and the current output accepts loads between zero and $270\ \text{ohms}$.

The analogue ground uses a separate terminal, which however internally is connected to the GND potential of the power supply.

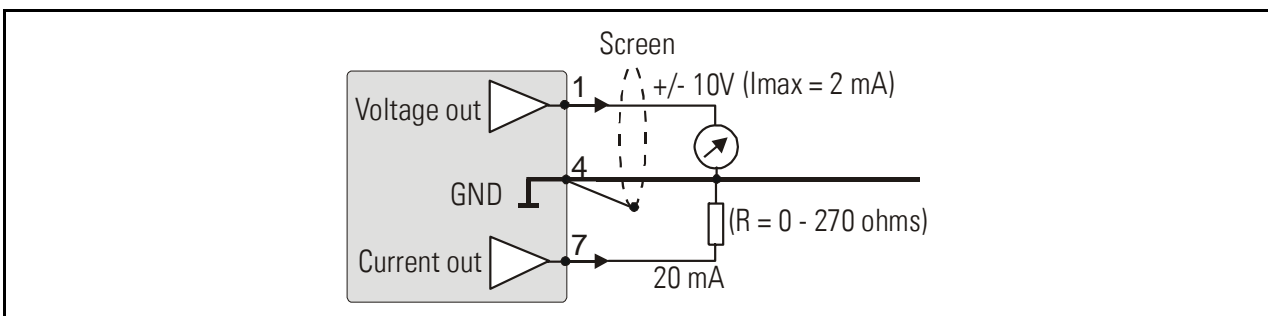

3.5. Serial interface

The unit provides a RS232 interface and a RS485 interface, however only one of the two can be used at a time. Serial communication allows to read out conversion results and to set parameters and variables by PC, according to need.

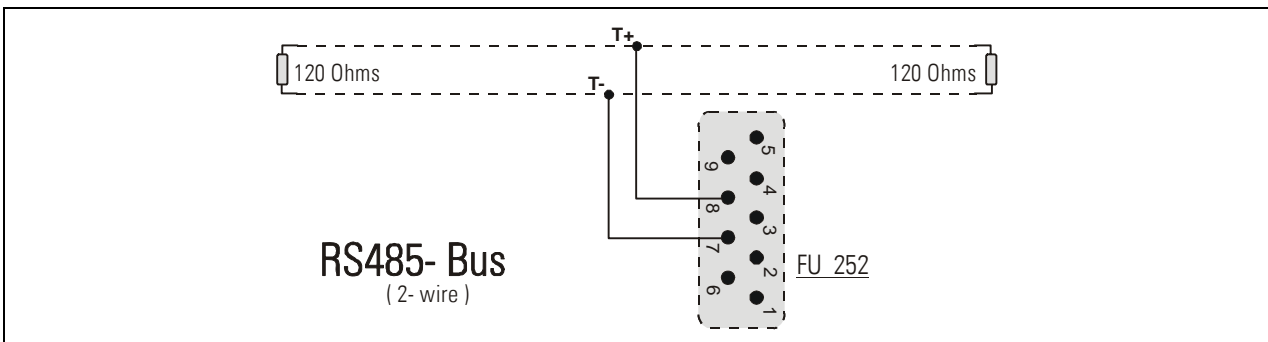
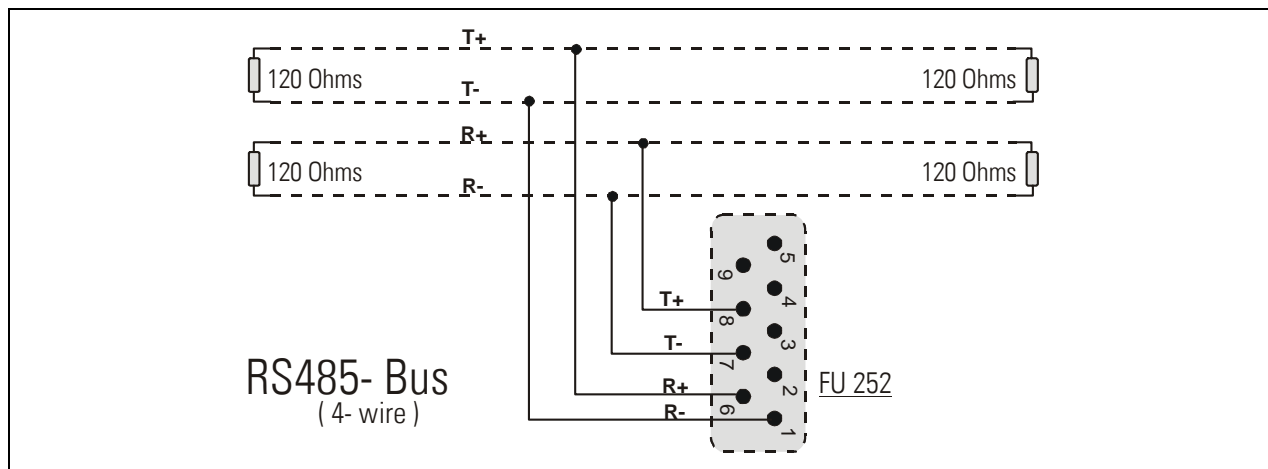
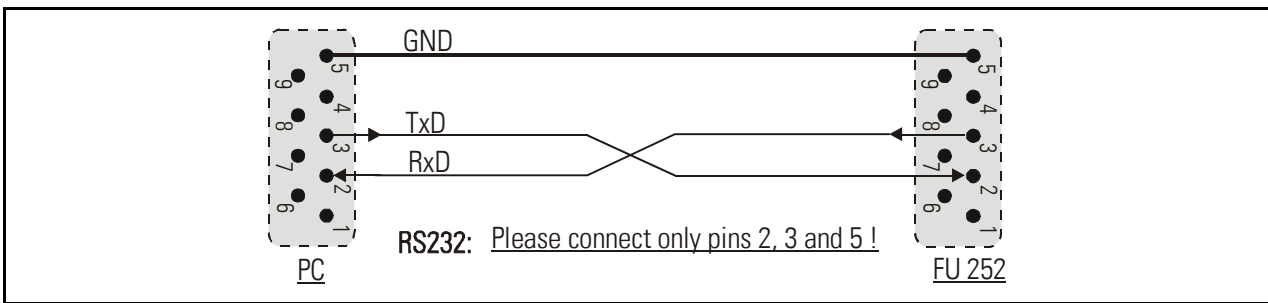
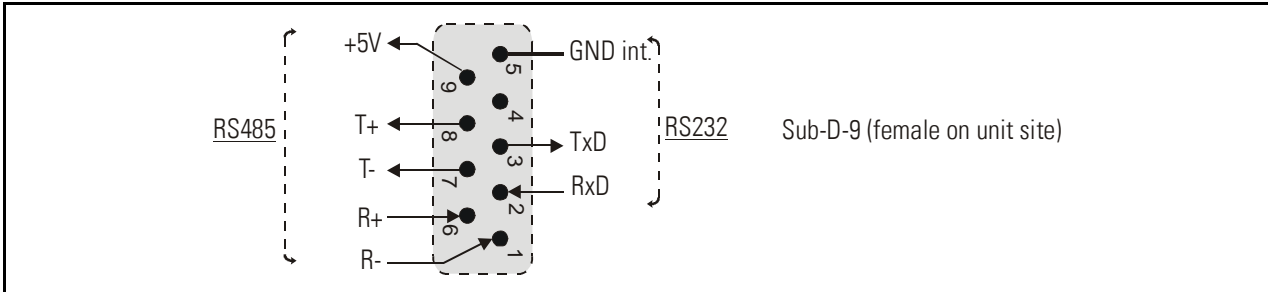

4. DIL Switch Settings

There is one 8-position switch located on the top side (DIL1), and another 8-position switch is located on the bottom side of the unit (DIL2). These switches provide major settings of the desired properties of the unit.



Changes of switch settings will become active only after cycling the power supply of the unit!

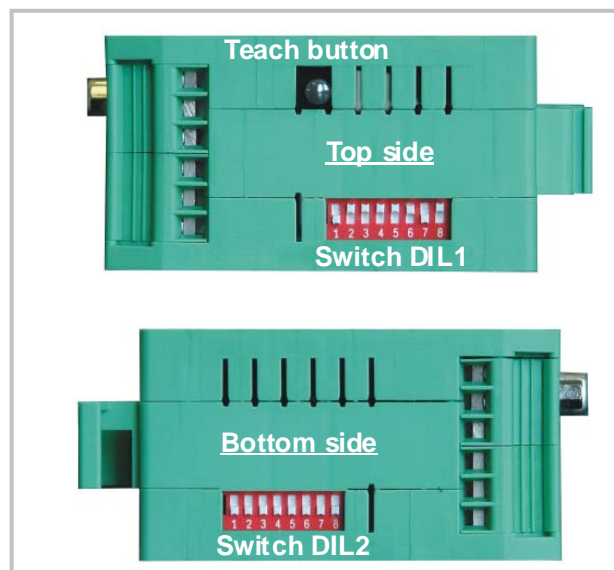

4.1. Basic mode of operation

Positions 2, 3 and 4 of switch DIL1 on the top side allow setting the following operation modes:

DIL1		Mode of operation		
<input type="checkbox"/>	<input checked="" type="checkbox"/>	<input type="checkbox"/>	<input type="checkbox"/>	Channel A only
<input type="checkbox"/>	<input type="checkbox"/>	<input type="checkbox"/>	<input type="checkbox"/>	Ratio A : B
<input type="checkbox"/>	<input type="checkbox"/>	<input type="checkbox"/>	<input checked="" type="checkbox"/>	Sum A + B
<input type="checkbox"/>	<input type="checkbox"/>	<input type="checkbox"/>	<input type="checkbox"/>	Quadrature A / B / 90°
<input type="checkbox"/>	<input checked="" type="checkbox"/>	<input type="checkbox"/>	<input type="checkbox"/>	Channel B only
<input type="checkbox"/>	<input checked="" type="checkbox"/>	<input type="checkbox"/>	<input type="checkbox"/>	Product A x B
<input type="checkbox"/>	<input type="checkbox"/>	<input checked="" type="checkbox"/>	<input type="checkbox"/>	Difference A - B
<input type="checkbox"/>	<input type="checkbox"/>	<input type="checkbox"/>	<input checked="" type="checkbox"/>	A = impulse, B = direction / sign

Setting example:
Quadrature input A / B / 90°

4.2. Impulse levels and symmetric / asymmetric input formats

Positions 5 and 7 of DIL1 together with positions 3 to 6 of DIL2 allow setting of all imaginable combinations of levels and formats.



- All subsequent tables use the following definitions:
 „0“ = switch OFF, „1“ = switch ON and
 „x“ = position not important
- Switch settings refer to impulse inputs A / B only, but the Control Input (terminal 10) provides always HTL / PNP format, i.e. you must apply a positive voltage 10 – 30 volts to activate the function
- Where you use 2-wire sensors with NAMUR characteristics, connect the positive pole of the sensor to the corresponding input terminal, and the negative pole to GND
- Where subsequently you read (A) or (B), this indicates that the inputs expect asymmetric signals and you will not need the corresponding inverted signals
- Where however you read (A and /A) or (B and /B), this indicates that the inputs expect symmetric differential signals according to RS422 standard, i.e. it is mandatory to apply also the inverted signals

4.2.1. Standard settings

If you just use encoders or sensors according to common industrial standards, and if also all input signals should have the same level, you just can use one of the following three standard settings and do not need to consider all further alternatives of switch settings.

DIL1			DIL2				Input Characteristics	Encoder Type
5	6	7	3	4	5	6		
0		0	0	0	0	0	Asymmetric HTL input (A, B), 10 - 30 V level, NPN (switching to -) or Push-Pull or NAMUR characteristics	Standard HTL encoders, Proximity switches, Photo switches etc.
1		0	0	0	0	0	Asymmetric HTL input (A, B), 10 - 30 V level, PNP (switching to +) or Push-Pull characteristics	PNP Proximity switches, Photo switches etc.
0		1	0	0	0	0	Symmetric TTL signals or RS422 signals (A, /A), (B, /B) (differential, including inverted signal)	Standard TTL encoders providing A, /A, B, /B output channels

4.2.2. Settings for special applications

Where you find that the standard settings shown before are not suitable for your application, please go through the following setting options and find out the input levels and characteristics you need.

DIL1			DIL2				Characteristics of input A	Characteristics of input B
5	6	7	3	4	5	6		
x		x	0	0	0	1	TTL level (A)	TTL level (B)
x		x	0	0	1	0	HTL level (A and /A)	HTL level (B and /B)
x		x	0	0	1	1	TTL level (A)	TTL level (B and /B)
x		x	0	1	0	0	TTL level (A and /A)	TTL level (B)
x		x	0	1	0	1	HTL level NPN (A)	HTL level PNP (B)
x		x	0	1	1	0	HTL level NPN (A)	TTL level (B and /B)
x		x	0	1	1	1	HTL level NPN (A)	TTL level (B)
x		x	1	0	0	0	HTL level PNP (A)	TTL level (B and /B)
x		x	1	0	0	1	HTL level PNP (A)	TTL level (B)
x		x	1	0	1	0	HTL level PNP (A)	HTL level NPN (B)
x		x	1	0	1	1	TTL level (A and /A)	HTL level NPN (B)
x		x	1	1	0	0	TTL level (A)	HTL level NPN (B)
x		x	1	1	0	1	TTL level (A and /A)	HTL level PNP (B)
x		x	1	1	1	0	TTL level (A)	HTL level PNP (B)

4.3. Analogue output format

The desired output format of the analogue output can be set by positions 1 and 2 of switch DIL2

DIL2		Output format	
1	2		
0	0	Voltage 0 ... +10 V	← With this setting the format depends on the parameter „Analogue Mode“ which can be set by PC. Since the factory default setting of parameter “Analogue Mode” is “1”, the format will be a 0 ... +10 V output under default conditions.
0	1	Voltage +/- 10 V	
1	0	Current 4 – 20 mA	
1	1	Current 0 – 20 mA	

4.4. Selecting the RS232 or the RS485 serial interface

Position 1 of switch DIL1 selects between the RS232 interface and the RS485 interface. All connection details have already been explained in section 3.5.

DIL1 / 1		Serial Interface
0		RS232 interface is active (RS485 is switched off)
1		RS485 interface is active (RS232 is switched off)

4.5. Teach function, Test function, loading of default settings

Positions 6 and 8 of switch DIL1 allow to set the following functions:

DIL1		Function
6	8	
x	0	Unit returns to the factory default parameters after power-down
x	1	Unit always keeps the parameters according to customer setting
0	x	Push button and yellow LED operate in TEACH mode (see 5.)
1	x	Push button and yellow LED operate in TEST mode, Teach is disabled (see 5.)



After successful commissioning, please make sure to set positions 6 and 8 to "ON". Otherwise, cycling of the power supply or touching the push button inadvertently would result in overwriting your parameter settings

5. Commissioning

With all basic applications, you can use the Teach feature for commissioning of the unit. Extended functions need a PC for setup and are described under section 7.

As a first step it is advisable to check the input frequencies by means of the LED marked "Status". DIL switch 6 must be set to ON for this test.

When you press the TEACH button one time, the yellow LED will be lit when the unit detects a frequency on input A. The LED will be OFF when no input frequency can be detected.

When you press the TEACH button once more, you can also check input B (if applicable). With all operation modes using two independent frequencies, again the yellow LED will be lit when a frequency has been detected on input B.

With operation modes using input B to define the direction and polarity (quadrature or static), the yellow LED will indicate that the actual input signals provide positive output (LED on) or negative output (LED off). Where you like to get the other polarity, you must change the information of direction on A/B inputs



- The TEACH function can only be used when the DIL switches are set for operations with one input frequency only (i.e. A only, B only, quadrature A/B or A = impulse and B = direction).
- You must switch over to combined operations $A + B$, $A - B$, $A \times B$ or $A : B$ only after you have successfully run the Teach function for both channels. Parameter „Teach-Mode“ will determine if or if not an automatic re-scaling will apply after switch-over.

5.1. Conversion of one only frequency (single channel or dual channel with direction signal)

Make sure that the DIL switches are set according to the encoder you use, and that position 6 of switch DIL1 is OFF (Teach function active).

- Self test: Upon power up, both front LED's must be lit first, and the yellow status LED must switch off after the self test has been concluded successfully (approx.1 sec.).
- Scaling of the analogue output with use of the Teach function:
Press the Teach button one time. The status LED will blink in a slow sequence while the unit waits for setting of the minimum frequency. Please make your encoder now generate the frequency where you expect your analogue output to be zero (in general this will be 0 Hz at standstill)
- Press the Teach button again. This stores your minimum frequency definition, the LED will blink in a fast sequence and the unit waits for setting of the maximum frequency. Please move your encoder now at a speed where you expect full scale analogue output.
- Press the teach button once more. This stores your maximum frequency definition and the LED will switch off. After this Teach procedure, your analogue output is set to a 0 – 10 volts range between the minimum and the maximum input frequency.

5.2. Conversion and combination of two independent frequencies (A + B, A - B, A x B, A : B)

In principle, the Teach procedure is the same as described under 5.1. However, we must first teach every of the two channels A and B separately.

- Set the DIL switch to "Channel A only" (see 4.1) and teach the minimum and the maximum frequency for channel A like shown before.
- Now set the DIL switch to "Channel B only" and run the teach procedure for minimum and maximum frequency of channel B.
- Finally, set the DIL switch according to the combination of the frequencies that you desire. The unit is able to automatically re-scale the output swing in a way that you receive full scale output when the result of the A/B calculation reaches the maximum (see parameter "Teach Mode").



Please observe that minimum and maximum frequency settings for inputs A and B must never be "0" when you intend to use the ratio function A : B !

6. PC Setup with Use of the Operator Software OS3.x

You can apply the full set of functions when you use a PC and our operator software OS3.x for setup of the unit (at this time the actual version is OS3.2).

You can download this software and full instructions, free of charge, from our homepage

www.motrona.com

Connect your PC to the converter, using a serial RS232 cable like shown in section 3.5 of this manual. Make sure, the cable only uses pins 2, 3 and 5. Pins 2 and 3 must be crossed.

Run the OS3.x software and you will see the following screen:

The screenshot displays the OS3.x software interface with the following sections:

- PARAMETERS:** A list of settings including Register-Setting (8), Multiplier (+001.0000), Divisor (+000.0000), Offset (0000000), General-Setting (Direction: 0, Filter AB: 00, Linearisation Mode: 0, Frequency Control: 00, Input Filter: 0, Reserved: 1000), Channel-A-Setting (Sampling Time A: 0.000, Wait Time A: 0.01, Filter A: 0, Reset Value A: +0000000.0), and Channel-B-Setting (Sampling Time B: 0.000, Wait Time B: 0.01, Filter B: 0, Reset Value B: +0000000.0).
- INPUTS:** Buttons for Teach Level, Teach Max., Teach Min., Input, Freeze Both, Freeze B, Freeze A, Reset Both, Reset B, Reset A, Activate Data, and Store EEPROM. It includes columns for RS, BUS, and P/I/O.
- OUTPUT VALUE:** A bar graph showing a value of -11% on a scale from -100% to +100%.
- SERIAL SETTINGS:** Fields for COM 2, 9600, 7, 1, E, and Unit 11.
- OUTPUTS:** A vertical stack of indicator lights for Unit Ready, Load Default Values, Status B, and Status A.
- CONTROLS:** Buttons for Read, Transmit, Transmit All, Store EEPROM, and Reset OFF.

In case your text and color fields remain empty and the headline says „OFFLINE“, you must verify your DIL switch setting and the serial settings of the unit. To access serial settings, please select „COMMS“ from the menu bar.



Ex factory, all motrona units use the following serial default settings:

Unit No. 11, Baud rate 9600, 1 start/ 7 data/ parity even/ 1 stop bit

If the serial settings of your unit should be unknown, you can run the „SCAN“ Function from the „TOOLS“ menu to find out.

On the left side of your screen you find the Edit window with all parameters.

Under „INPUTS“ you find some softkeys allowing to switch ON or OFF of the Control commands. Indicator boxes in the RS column signal if the corresponding command is set by serial communication. Indicator boxes in the PI/O column indicate if the same command is set by hardware input.

Under OUTPUTS you can get information about the state of the unit. The indicator boxes „Status A“ and „Status B“ especially serve to check the input frequencies:

- Status A will be lit while a frequency is detected on input A (except with operating mode „B single“)
- Status B will be lit while a frequency is detected on input B (except with operating modes „A single“, „A/B_dir“ and „A/B_90“)

The color bar in the “Output Value” field indicates the actual percentage of the output signal in a range of +/- 100 %.

The Control keys allow Read-out, Transmission and saving of parameter settings.



For enduring memorization of parameters entered by keypad, you should press the ENTER key every time you have completed one line.

Optionally you can also use the Softkeys „Transmit“ or „Transmit All“ for temporary storage of your last setting or all previous settings (storage until next power-down), and finally use the „Store EEPROM“ key when you like to have an enduring storage of all settings transmitted before.

7. Parameter Description

Parameter	Description									
Register Setting (:8): Multiplier Divisor Offset	<p>These operands allow converting the result to the desired engineering units.</p> <p>This conversion affects the numeric value for serial read out from register (:8) only, but not the scaling of the analogue output.</p> <p>With settings</p> <table style="margin-left: 40px;"> <tr> <td><u>Multiplier</u></td> <td>=</td> <td>1,0000</td> </tr> <tr> <td><u>Divisor</u></td> <td>=</td> <td>1,0000</td> </tr> <tr> <td><u>Offset</u></td> <td>=</td> <td>00000</td> </tr> </table> <p>the readout from register < :8 > equals to the percental result (xxx.xxx%) , where 100,000% has been defined by the TEACH minimum and TEACH maximum settings</p>	<u>Multiplier</u>	=	1,0000	<u>Divisor</u>	=	1,0000	<u>Offset</u>	=	00000
<u>Multiplier</u>	=	1,0000								
<u>Divisor</u>	=	1,0000								
<u>Offset</u>	=	00000								
<div style="display: flex; align-items: center; justify-content: center; gap: 10px;"> <div style="border: 1px solid black; padding: 5px;">Read-out from (:8)</div> <div>=</div> <div style="border: 1px solid black; padding: 5px;">Measuring result in % of full scale</div> <div>×</div> <div style="border: 1px solid black; padding: 5px; text-align: center;"> $\frac{\text{Multiplier}}{\text{Divisor}}$ </div> <div>+</div> <div style="border: 1px solid black; padding: 5px;">Offset</div> </div>										
<div style="display: flex; align-items: center; justify-content: center; gap: 10px;">  <div style="border: 1px solid gray; padding: 10px;"> <p>When you set "Divisor" to 0, this will completely skip all calculations. This step is advisable when you need very fast response with the shortest conversion time possible.</p> </div> </div>										
General Setting: Direction Filter A/B Linearisation Mode	<p>This parameter allows inversion of the polarity of the analogue output. (Important only with operating modes A/B (2x90°) or A = Impulse and B = direction.</p> <p>0 = no inversion 1 = output inverted</p> <p>Digital filter for smoothing the analogue output with combined modes (calculations from A and B)</p> <p>00 = Filter off (immediate response to changes of the input signal) 01 = Filter with time constant 1,563 msec 02 = Filter with time constant 3,125 msec 03 = Filter with time constant 6,250 msec etc. 12 = Filter with time constant 3200 msec (slow response)</p> <p><u>Please note:</u> These time constants are valid for sampling time settings of 1 msec. and higher sampling times will correspondingly increase the time constant</p> <p>0 = Linearisation OFF, parameters P1 to P16 are irrelevant. 1 = Linearisation in a range from 0% to 100 % 2 = Linearisation over full range -100% to +100% <u>See example under section „Linearisation“</u></p>									

Parameter	Description
Frequency Control	Frequency control and response characteristics to frequency gaps for channels A and B. This setting is taken as a 4 bit binary value. Range 00 – 15, default setting 10 (only to be changed in special case)*)
Input Filter	Programmable hardware filter for the impulse inputs 0 = no filtering 1 – 3 : filter low – medium - high
Channel A Setting	
Sampling Time A	Time base for measuring the frequency on input A Range 0 – 9,999 seconds Setting 0 provides a sampling time of 750 µsec.
Wait Time A	Zero setting time for missing frequency on input A. Range 0.01 – 9.99 seconds The analogue signal goes to zero when no input impulse appears during the Wait Time. <u>Example:</u> With setting 0,01 sec. all frequencies <100 Hz will produce zero output
Filter A	Digital filter for smoothing the analogue output with unstable frequencies on input A. 00 = Filter off (immediate response to changes of the input signal) 01 = Filter with time constant 1.563 msec 02 = Filter with time constant 3.125 msec 03 = Filter with time constant 6.250 msec etc. 07 = Filter with time constant 100 msec (slow response) <u>Please note:</u> These time constants are valid for sampling time settings of 1 msec. and higher sampling times will correspondingly increase the time constant
Reset Value A	Range -1 100 000,0 to +1 100 000,0 Input A will be overwritten by this simulated frequency value, if the control input is active and the "Reset A" function has been assigned to the control input.

*) This Parameter is only relevant when remarkable Sampling Times are used. It determines the way how the unit responds to gaps within one sampling period.

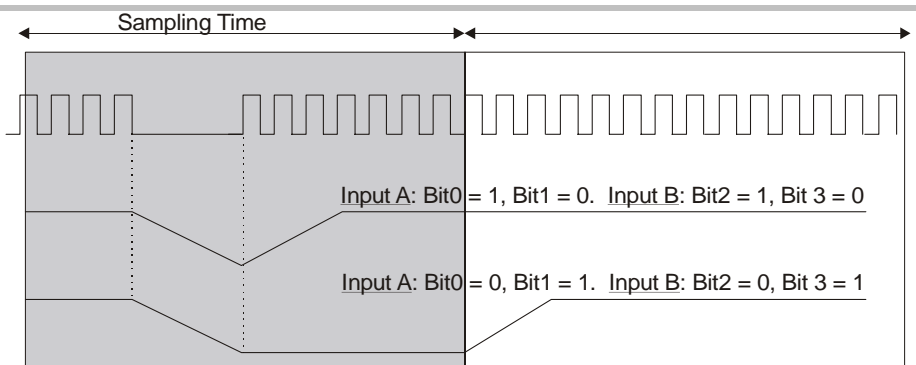

Parameter	Description
Channel B Setting	
Sampling Time B	Time base for measuring the frequency on input B Range 0 – 9,999 seconds Setting 0 provides a sampling time of 750 µsec.
Wait Time B	Zero setting time for missing frequency on input B. Range 0.01 – 9.99 seconds The analogue signal goes to zero when no input impulse appears during the Wait Time. <u>Example:</u> With setting 0,01 sec. all frequencies <100 Hz will produce zero output
Filter B	Digital filter for smoothing the analogue output with unstable frequencies on input B. 00 = Filter off (immediate response to changes of the input signal) 01 = Filter with time constant 1.563 msec 02 = Filter with time constant 3.125 msec 03 = Filter with time constant 6.250 msec etc. 07 = Filter with time constant 100 msec (slow response) <u>Please note:</u> These time constants are valid for sampling time settings of 1 msec. and higher sampling times will correspondingly increase the time constant
Reset Value B	Range -1 100 000,0 to +1 100 000,0 Input B will be overwritten by this simulated frequency value, if the control input is active and the "Reset B" function has been assigned to the control input.
Analogue Setting	
Teach Minimum A	These two couples of settings define your minimum and maximum input frequency for input A and input B (if applicable), where your analogue output moves between 0 V and 10 V. This is how you can enter your minimum and maximum settings: <ul style="list-style-type: none"> • either by operating the Teach pushbutton, like described already under 5.1 • or by entering the frequency settings directly by keyboard to the parameter field of your screen, without using the TEACH function
Teach Maximum A	
Teach Minimum B	
Teach Maximum B	

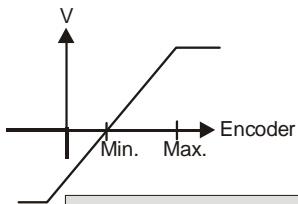
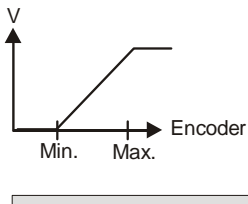
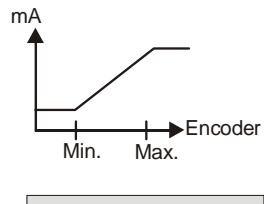
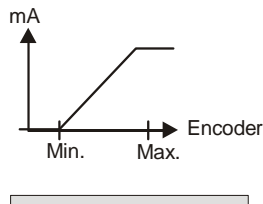
Parameter	Description
Teach Mode	<p>This parameter is only important when your application provides a combination of the two inputs (e.g. A + B). The setting determines how to scale the total result of the selected A/B calculation</p> <p>Teach Mode = 0: The unit will automatically calculate a new "full scale" output, resulting from the expected maximum values that can come up with the combined result from A and B *)</p> <p>Teach Mode = 1: The total result will use the same scaling as applied to input channel A *)</p> <p>Teach Mode = 2: Before calculating the combination result, the channel B frequency will be pre-scaled using the conversion parameters „Multiplier“ and „Divisor“ , so that a direct compare between two frequencies of different scaling can take place.</p>
Analogue Mode:	<p>Determines which analogue output format should be used (see 4.3):</p> <div style="display: flex; justify-content: space-around; align-items: flex-start;"> <div style="text-align: center;">  <p>Output Mode = 0 -10V ... 0 ... +10V</p> </div> <div style="text-align: center;">  <p>Output Mode = 1 0 ... +10V</p> </div> <div style="text-align: center;">  <p>Output Mode = 2 4 ... 20 mA</p> </div> <div style="text-align: center;">  <p>Output Mode = 3 0 ... 20 mA</p> </div> </div>
Analogue Offset:	<p>Parameter to shift the zero position of the analogue output over the full range of +/- 9999 mV respectively +/-19,998 mA (if applicable). Normal setting is 0.</p>
Analogue Gain:	<p>Allows setting the maximum swing of the analogue output. Setting 1000 results in a full scale signal of 10 volts or 20 mA, setting 500 will reduce the signal to 5 volts etc..</p>

*) **Example:** Provided you have set both inputs A and B to a range of 0 – 10 kHz for a 0 – 10 volts output, and after this you switch over to the sum mode A + B:

Teach Mode = 0 would allow to apply the full frequency range of 10 kHz to each of the inputs at the same time, because the automatic re-scaling function has set a full range scale of 20 kHz for the expected maximum of the sum A + B.

Teach Mode = 1 would reach the full-scale output already with a sum of A + B = 10 kHz, because only the 10 kHz / 10 volts scaling of input A will apply

Parameter	Description																																												
Serial Communication:																																													
Serial Unit No.:	<p>With RS 485 applications it is necessary to attach a specific address to each unit, since up to 32 units can be connected to the same bus. You can choose any address number between 11 and 99.</p> <p>The address must however not contain a "0" because these numbers are reserved for collective addressing.</p>																																												
Serial Baud Rate:	<table border="1"> <thead> <tr> <th>Setting</th> <th>Baud Rate</th> </tr> </thead> <tbody> <tr> <td>0*</td> <td>9600</td> </tr> <tr> <td>1</td> <td>4800</td> </tr> <tr> <td>2</td> <td>2800</td> </tr> <tr> <td>3</td> <td>1200</td> </tr> <tr> <td>4</td> <td>600</td> </tr> <tr> <td>5</td> <td>19 200</td> </tr> <tr> <td>6</td> <td>38 400</td> </tr> </tbody> </table> <p style="text-align: center;">* = Factory setting</p>	Setting	Baud Rate	0*	9600	1	4800	2	2800	3	1200	4	600	5	19 200	6	38 400																												
Setting	Baud Rate																																												
0*	9600																																												
1	4800																																												
2	2800																																												
3	1200																																												
4	600																																												
5	19 200																																												
6	38 400																																												
Serial Format:	<table border="1"> <thead> <tr> <th>Setting</th> <th># data bits</th> <th>Parity</th> <th># stop bits</th> </tr> </thead> <tbody> <tr> <td>0*</td> <td>7</td> <td>even</td> <td>1</td> </tr> <tr> <td>1</td> <td>7</td> <td>even</td> <td>2</td> </tr> <tr> <td>2</td> <td>7</td> <td>odd</td> <td>1</td> </tr> <tr> <td>3</td> <td>7</td> <td>odd</td> <td>2</td> </tr> <tr> <td>4</td> <td>7</td> <td>none</td> <td>1</td> </tr> <tr> <td>5</td> <td>7</td> <td>none</td> <td>2</td> </tr> <tr> <td>6</td> <td>8</td> <td>even</td> <td>1</td> </tr> <tr> <td>7</td> <td>8</td> <td>odd</td> <td>1</td> </tr> <tr> <td>8</td> <td>8</td> <td>none</td> <td>1</td> </tr> <tr> <td>9</td> <td>8</td> <td>none</td> <td>2</td> </tr> </tbody> </table> <p style="text-align: center;">* = Factory setting</p>	Setting	# data bits	Parity	# stop bits	0*	7	even	1	1	7	even	2	2	7	odd	1	3	7	odd	2	4	7	none	1	5	7	none	2	6	8	even	1	7	8	odd	1	8	8	none	1	9	8	none	2
Setting	# data bits	Parity	# stop bits																																										
0*	7	even	1																																										
1	7	even	2																																										
2	7	odd	1																																										
3	7	odd	2																																										
4	7	none	1																																										
5	7	none	2																																										
6	8	even	1																																										
7	8	odd	1																																										
8	8	none	1																																										
9	8	none	2																																										
Serial Protocol:	<p>Determines the sequence of characters sent, when you use the serial output for cyclic data transmission under timer control (xxxxxx is the measuring value transmitted).</p> <p>Setting "1" will suppress transmission of the unit number, therefore the transmission cycle is shorter than with setting "0"</p>																																												
Unit No.																																													
Serial Protocol = 0 :	<table border="1"> <tbody> <tr> <td>1</td> <td>1</td> <td>+/-</td> <td>X</td> <td>X</td> <td>X</td> <td>X</td> <td>X</td> <td>X</td> <td>X</td> <td>LF</td> <td>CR</td> </tr> </tbody> </table>	1	1	+/-	X	X	X	X	X	X	X	LF	CR																																
1	1	+/-	X	X	X	X	X	X	X	LF	CR																																		
Serial Protocol = 1 :	<table border="1"> <tbody> <tr> <td></td> <td></td> <td>+/-</td> <td>X</td> <td>X</td> <td>X</td> <td>X</td> <td>X</td> <td>X</td> <td>X</td> <td>LF</td> <td>CR</td> </tr> </tbody> </table>			+/-	X	X	X	X	X	X	X	LF	CR																																
		+/-	X	X	X	X	X	X	X	LF	CR																																		

Parameter	Description
Serial Timer:	This register determines the cycle time in seconds for cyclic transmission when the Printer Mode is switched on. Range 0.001 to 9.999 seconds. With setting "0" all cyclic transmission is switched off and the unit will only send data upon request (PC mode *)
Serial Value:	Sets the code of the register of which the content should be sent with cyclic transmission. Setting range 00 – 09 (corresponds to register codes :0 to :9) and 10 - 19 (corresponds to register codes ;1 to ;9) For clarification of register codes see section 9.

*) The serial port of the unit can operate in either "PC-Mode" or in "Printer Mode".

With "PC-Mode", the unit receives a request string and responds with a corresponding data string. For details of the protocol see separate description "SERPRO".

With "Printer Mode" the unit sends data without any request and under Timer control as described subsequently.

As soon as the unit receives a character, it automatically switches over to PC Mode and operates according to protocol. When for a period of 20 sec. no character has been received, the unit switches automatically back to "Printer Mode" and starts cyclic data transmission again.



<u>Input Setting:</u>	
Input Configuration:	Sets the switching characteristics of the „Control“ input (terminal 10): 0 = function „active HIGH“, 1 = function „active LOW“
Input Function:	Selects the function of the "Control" input (terminal 10): 0 = no control function 1 = Replaces the frequency applied to input A by a fixed frequency value as set under parameter „Reset Value A“ 2 = Replaces the frequency applied to input B by a fixed frequency value as set under parameter „Reset Value B“ 3 = Replaces the result of the combination A / B by a fixed value as set under parameter „Reset Value A/B“ 4 = Freezes the actual frequency value of input A 5 = Freezes the actual frequency value of input B 6 = Freezes both frequencies A and B 7 = Starts a serial transmission of the defined register value

Parameter	Description
<u>Both Channel Setting:</u> Multiplier: Divisor: Offset:	These settings provide a final scaling of the calculation result from the combined operation modes A / B
<u>Linearisation Setting:</u> P1_x to P16_x: P1_y to P16_y:	Interpolation points for linearisation (initial values) Interpolation points for linearisation (substitute values) (For clarification see section 9.)

8. Free Programmable Linearization

This programmable feature allows the user to convert a linear input signal to a non-linear analogue output. There are 16 programmable x/y coordinates available, which can be set in any desired distance over the full conversion range. Between two coordinates, the unit uses linear interpolation. Therefore it is advisable to use more coordinates in a range with strong curves and only a few coordinates where the curvature is less.

To specify your desired linearisation curve, you must first set the „Linearisation Mode“ register to either 1 or 2.

Use registers P1(x) to P16(x) to specify the coordinates on the x-axis. These are the analogue output values that the unit normally would generate according to the actual input frequency. These settings must be in % of full scale.

Now enter the attached values to registers P1(y) to P16(y). These are the values that the analogue output will generate instead of the x- values, i.e. P2(y) will substitute P2(x) etc.



- x-registers must use continuously increasing settings, i.e. P1(x) must have the lowest and P16(x) must have the highest setting
- All entries use a percental format of xx.xxx% full scale. Setting 000.000% means zero output and setting 100.000% means full scale output.
- With Linearisation Mode set to 1, it is a must to set P1(x) to 0% and P16(x) to 100%. Linearisation is defined in the positive range only and the negative range will be a mirror image of the positive range with reference to zero.
- With Linearisation Mode set to 2, it is a must to set P1(x) to -100% and P16(x) to +100%. This enables the user to set curves which are not symmetric to the zero position.

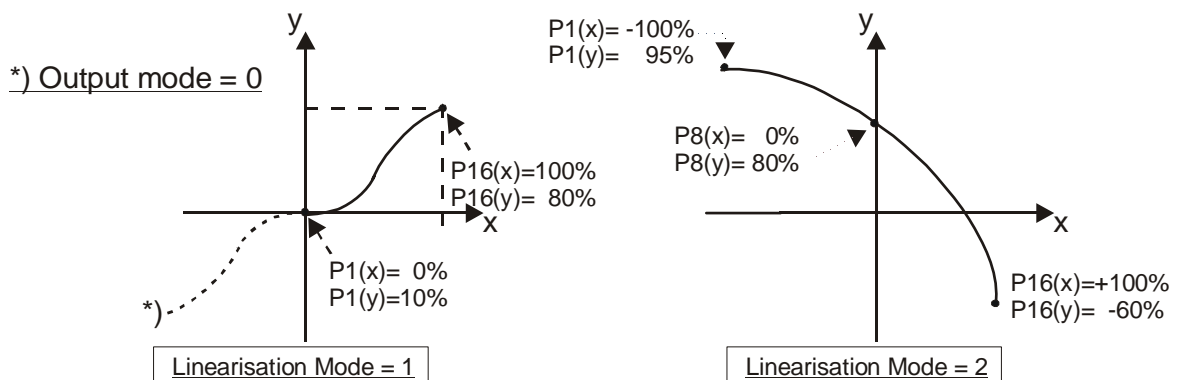

You can visualize your curve on the PC screen or by means of an external oscilloscope. For this, select TOOLS, then TEST and there „Analogue Voltage Function“. The unit will now simulate a repeating frequency course over the full range and generate the analogue signal accordingly. When you use the Scope function of the operator software, you must set the serial code to „:1“ to record the analogue output.

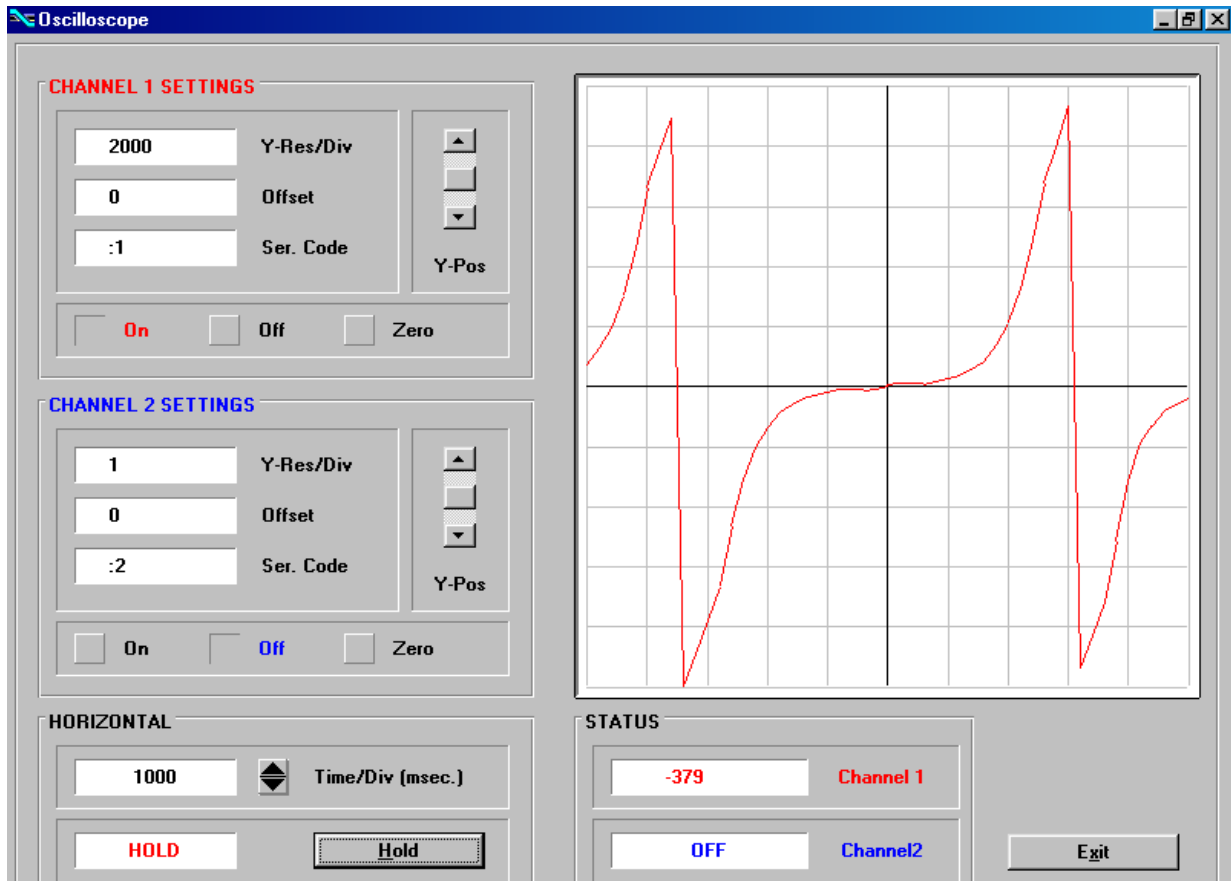

9. Monitor Functions

The monitor function of the OS3.2 PC software allows to display some important data on the PC screen with a continuous refresh cycle.

Select „Monitor“ from the „Tools“ menu to open the basic view of the monitor window. Click to “Define” to open the definition window. You will find a list with all accessible parameters and actual values, where however the texts may be unfounded.

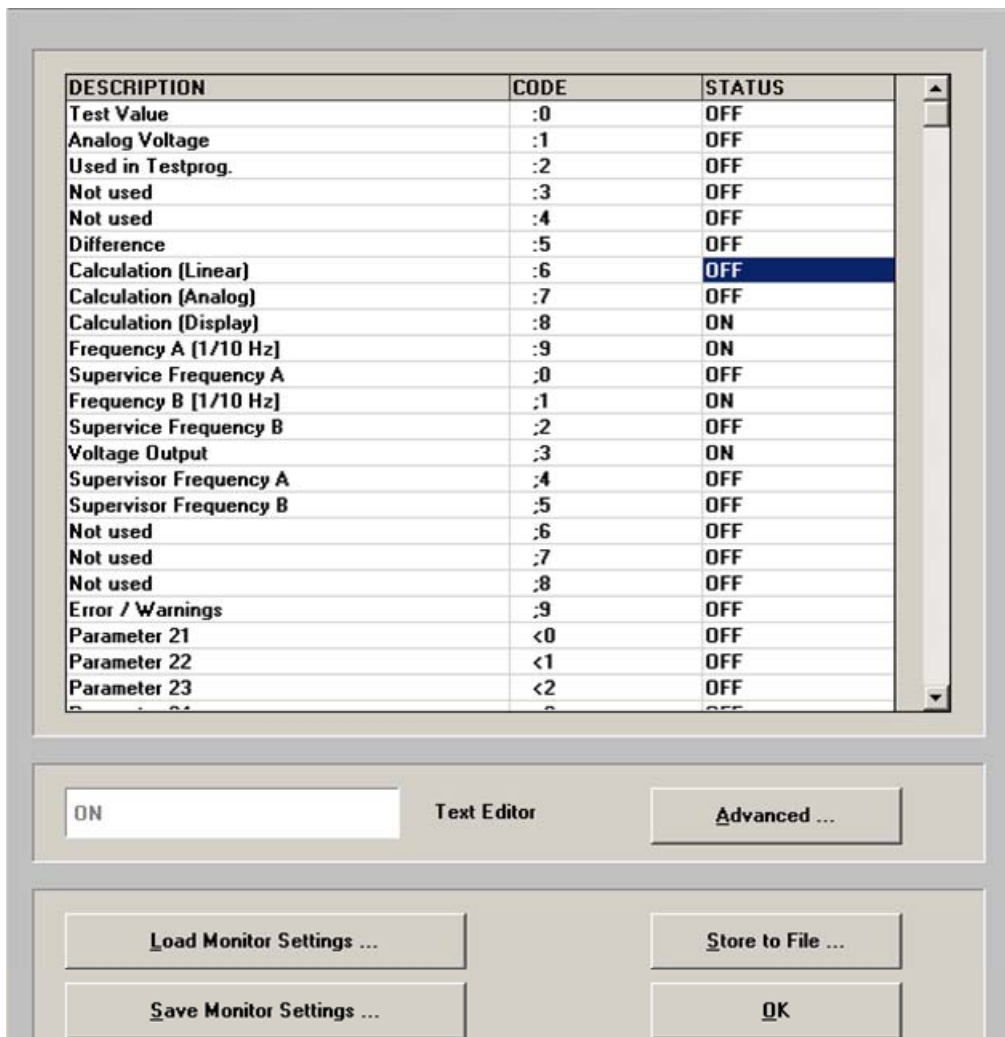

With FU252, only the following register codes make sense:

C1	C2	Description
:	8	Actual conversion result in % of full-scale, format xxx.xxx % *)
:	9	Actual frequency on input A in Hz, resolution 0,1 Hz, format xxx xxx,x Hz
;	1	Actual frequency on input B in Hz, resolution 0,1 Hz, format xxx xxx,x Hz
;	3	Actual output voltage of the analogue output, scaling 0 – 10 000 millivolts

10. Data Readout via Serial Interface

All register codes from section 9. are also available for serial readout by PC or PLC. For communication the FU252 converter uses the Drivecom Protocol according to ISO 1745. All protocol details can be found in our manual **SERPRO_2a.doc** which is available for download from our homepage

www.motrona.com

To request for a data transmission you must send the following request string to the converter:

EOT		AD1	AD2	C1	C2	ENQ
EOT = control character (Hex 04) AD1 = unit address, High Byte AD2 = unit address, Low Byte C1 = register code, High Byte C2 = register code, Low Byte ENQ = control character (Hex 05)						

The following example shows the request string for readout of the actual frequency of input A (code :9) from a unit with unit address 11:

ASCII Code:	EOT	1	1	:	9	ENQ
Hex Code:	04	31	31	3A	39	05
Binary Code:	0000 0100	0011 0001	0011 0001	0011 1010	0011 1001	0000 0101

After a correct request, the unit will respond:

STX	C1	C2	x x x x x x x	ETX	BCC
STX = control character (Hex 02) C1 = register code, High Byte C2 = register code, Low Byte xxxxx = readout data ETX = control character (Hex 03) BCC = block check character					

For all further details see SERPRO_2a.doc.

11. Dimensions

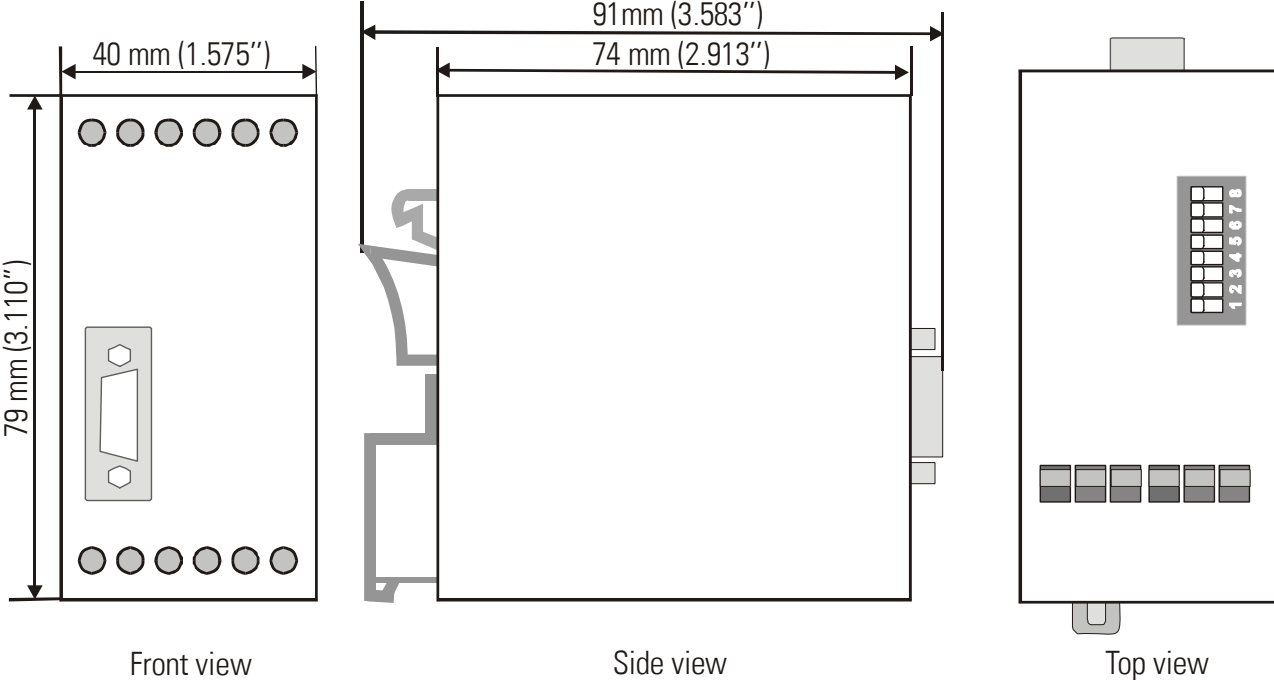

12. Specifications

Power supply	:	18...30 V DC
Current consumption	:	about 85 mA with 18 V, about 60 mA with 30 V (aux. output unloaded)
Aux. encoder supply	:	+5.5V +/- 5% (max.: 250mA)
Inputs (RS422/TTL differential)	:	RS422 compatible (differential level min. 1 V) or TTL differential, $f_{max} = 1$ MHz
Inputs TTL single-ended	:	LOW < 0.5V, HIGH > 2.5V, $f_{max} = 200$ kHz
Inputs HTL single-ended	:	LOW < 3V, HIGH > 10V, $f_{max} = 200$ kHz, ($R_i=4,75$ kOhms)
Input „Control“	:	LOW < 3V, HIGH > 10V, min. pulse duration 5 msec.
Analogue outputs	:	+/- 10V (external load > 5 kOhms) 0-20 mA / 4-20 mA (load < 270 Ohms) Accuracy +/-0.1%
Step width of analogue signals	:	1.25mV / 2.5uA
Analogue resolution	:	14 bits (+10V / +20mA respectively -10V/ -20mA)
Accuracy of frequency measurement	:	0.02 % +/- 1 digit
Response time of the analogue output in normal operation	:	approx. 1 msec ($f_{in} > 10$ kHz); $1/f_{in}$ ($f_{in} < 1$ kHz) (depending on Sampling Time and frequency)
Zero reset time of analogue signal with sudden input interruption	:	5 msec (filter off), 700 msec. (max. filtering)
Temperature range	:	Operation: 0° ... +45°C (+32 ... +113°F) Storage: -25° ... +70°C (-13 ... +158 °F)
Weight	:	approx. 190 g
Conformity and standards	:	EMC 89/336/EEC: EN 61000-6-2 EN 61000-6-3 LV73/23/EEC: EN 61010-1

13. Internal Registers and Serial Codes

#	Name	Code	CmdBit	SerStatus	BusStatus	ExtStatus
7	FreezeBoth	61	0040	Yes	No	Yes
8	FreezeB	62	0020	Yes	No	Yes
9	FreezeA	63	0010	Yes	No	Yes
10	ResetBoth	64	0008	Yes	No	Yes
11	ResetB	65	0004	Yes	No	Yes
12	ResetA	66	0002	Yes	No	Yes
13	ActivateData	67	1000	Yes	No	No
14	StoreEEProm	68	0001	Yes	No	No

Parameters

#	Menu	Name	Code	Min	Max	Default
0	Register-Setting(:8)	Multiplier	00	-1000000	1000000	10000
1		Divisor	01	0	1000000	0
2		Offset	02	-1000000	1000000	0
3	General-Setting	Direction	46	0	1	0
4		FilterAB	11	0	12	0
5		LinearisationMode	08	0	2	0
6		FrequencyControl	D2	0	15	0
7		InputFilter	D3	0	3	10
8	Channel-A-Setting	SamplingTimeA	33	0	9999	0
9		WaitTimeA	09	1	999	100
10		FilterA	D6	0	7	0
11		ResetValueA	D7	-10000000	10000000	0
12	Channel-B-Setting	SamplingTimeB	34	0	9999	0
13		WaitTimeB	10	1	999	100
14		FilterB	D8	0	7	0
15		ResetValueB	D9	-10000000	10000000	0
16	Analogue-Setting	TeachMinA	03	-10000000	10000000	0
17		TeachMaxA	04	-10000000	10000000	10000
18		TeachMinB	05	-10000000	10000000	0
19		TeachMaxB	06	-10000000	10000000	10000
20		TeachMode	12	0	2	0
21		AnalogueMode	07	0	3	0
22		AnalogueOffset	47	-9999	9999	0
23		AnalogueGain	48	0	10000	1000
24		Reserved	E0	0	9999	1000
25	Serial-Communication	SerialUnitNo.	90	0	99	11
26		SerialBaudRate	91	0	6	0
27		SerialFormat	92	0	9	0
28		SerialProtocol	30	0	1	0
29		SerialTimer	31	0	99999	0
30		SerialValue	32	0	19	0

#	Menu	Name	Code	Min	Max	Default
31	Input-Setting	InputConfiguration	E2	0	1	0
32		InputFunction	E3	0	7	0
33	Both-Channel-Setting	Multiplier	13	-1000000	1000000	10000
34		Divisor	14	1	1000000	10000
35		Offset	15	-1000000	1000000	0
36	Linearisation-Setting	P1(x)	A0	-100000	100000	100000
37		P1(y)	A1	-100000	100000	100000
38		P2(x)	A2	-100000	100000	100000
39		P2(y)	A3	-100000	100000	100000
40		P3(x)	A4	-100000	100000	100000
41		P3(y)	A5	-100000	100000	100000
42		P4(x)	A6	-100000	100000	100000
43		P4(y)	A7	-100000	100000	100000
44		P5(x)	A8	-100000	100000	100000
45		P5(y)	A9	-100000	100000	100000
46		P6(x)	B0	-100000	100000	100000
47		P6(y)	B1	-100000	100000	100000
48		P7(x)	B2	-100000	100000	100000
49		P7(y)	B3	-100000	100000	100000
50		P8(x)	B4	-100000	100000	100000
51		P8(y)	B5	-100000	100000	100000
52		P9(x)	B6	-100000	100000	100000
53		P9(y)	B7	-100000	100000	100000
54		P10(x)	B8	-100000	100000	100000
55		P10(y)	B9	-100000	100000	100000
56		P11(x)	C0	-100000	100000	100000
57		P11(y)	C1	-100000	100000	100000
58		P12(x)	C2	-100000	100000	100000
59		P12(y)	C3	-100000	100000	100000
60		P13(x)	C4	-100000	100000	100000
61		P13(y)	C5	-100000	100000	100000
62		P14(x)	C6	-100000	100000	100000
63		P14(y)	C7	-100000	100000	100000
64		P15(x)	C8	-100000	100000	100000
65		P15(y)	C9	-100000	100000	100000
66		P16(x)	D0	-100000	100000	100000
67		P16(y)	D1	-100000	100000	100000