

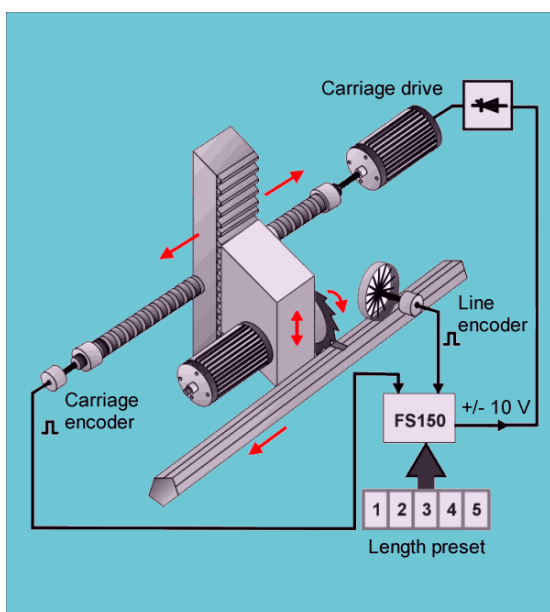

FS 150

High Performance Flying Shear Control



- Stand alone controller for “Cut on the fly“ applications
- Can operate with Servo- or DC- or AC- inverter drives
- High accuracy, 300 kHz input frequency
- Highly dynamic, 150 μ sec response time
- Easy remote length preset by thumbwheel switches or PLC or host computer
- Easy LCD display setting or PC setting via serial link
- RS232/RS485 and CANopen interface
- Speed transitions by \sin^2 profile. Speed variable anticipation for carriage start.
- Print mark registration and batch counters included.

Table of Contents:

1. Introduction	Page	4
2. Principle of Operation	Page	5
3. Hardware Configuration	Page	5
4. Terminal Assignments and Basic Settings	Page	6
4.1 Encoders	Page	8
4.2 Analogue Output	Page	11
4.3 Power Supply	Page	11
4.4 Parallel Interface	Page	11
5. Control IN/OUT Port (PI/PO)	Page	13
6. The Serial Port	Page	16
7. Register settings	Page	17
8. Auxiliary Register and Command Codes	Page	26
9. How to operate the Keypad	Page	27
10. The LED Display	Page	28
11. Steps for commissioning	Page	29
12. Alarm States and Conditions	Page	35
13. Accuracy considerations	Page	35
14. Which shortest length can we cut at a certain line speed?	Page	37
15. Which maximum line speed can we use with a certain cutting length	Page	38
16. Which travelling distance does our carriage need?	Page	38
17. General Master Reset and Erase of EEPROM	Page	38
18. The BY 106-X Remote Thumbwheel Switch	Page	40
19. Dimensions and Specifications	Page	41
20. History	Page	43

Important Notice:

Versions FS 15014A and higher use some different control inputs and outputs and therefore are not fully hardware compatible to former versions!

You must modify a few connections at the PI/PO connector when replacing older version against FS 15014A or a higher version! See section 5.

The software has been upgraded and now includes

- Batch counters for total quantity, waste quantity, total length
- Registers for actual line speed, carriage speed, synchronising error etc.
- 3 software limit switches to protect against carriage overshoot. No more proximities for extreme carriage positions necessary.
- Real acceleration settings instead of ramp times
- Virtual master axis with adjustable simulation speed
- Impulse output with scaling facility for material line
- Correction register for easy compensation of slip of the measuring wheel
- Enhanced setup tools in the OS30 operator software, including scope functions, providing still easier commissioning procedures.
- Improved S- shape profile for still higher cutting efficiency.

1. Introduction

Flying shears are used for cutting applications, where endless material to be cut to length cannot be stopped during the cutting process and the cut must be effected “on the fly“. The mechanical construction provides a saw or shear system mounted on a carriage, that follows the material with synchroneous speed while cutting is in progress, and then returns to a home position to wait for the next cut. See schematics on title page.

The FS flying shear control is based on a BY 150 synchroniser system. The software has been designed for the special requirements of flying shears under consideration of maximum efficiency and accuracy at minimum stress for all mechanical parts.

Only a few registers must be set in order to adapt the controller to the mechanical and electrical specifications of the shear system.

A small keypad with LCD provides easy setup, but also a disc with operator software OS30 is included for easy PC setup of the controller.

All essential registers like cutting length, tool width etc. are also accessible by parallel interface, providing easy setting by remote BCD thumbwheel switch or PLC parallel output.

The unit uses a closed 19“ steel cassette for maximum EMC protection. With option **SM150**, the housing can also be mounted on DIN rails.

2. Principle of Operation

The shear (or saw blade) is fixed on a carriage that can move forward and reverse under control of a +/- 10V speed reference voltage of the carriage drive. Normally, a 4 quadrant DC or servo drive is used. For lower requirements in performance, the FS150 unit can also control 1-quadrant AC drives using a positive speed reference signal and two outputs for forward/reverse select.

The FS 150 controller counts the length from the line encoder (feed roll or measuring wheel) while the carriage is held in its rear home position.

Once the cutting position approaches, the carriage accelerates and synchronises with the line. A "Ready to cut" signal is generated in order to start the cutting process, while the shear moves fully synchronous with the cutting position on the material. When the cut is completed, the FS 150 must receive a "cut complete" signal. This will cause a deceleration and a reversal of the carriage until it has reached it's home position again. All speed transitions occur with a smooth \sin^2 speed profile for absolutely careful treatment of screws and other mechanicals parts.

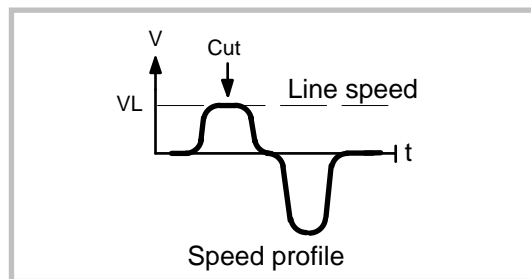

Fig 1

The FS 150 control continuously measures the line speed and calculates an anticipation value to start the carriage **before** the cutting length is reached. Thus the shear will exactly match the cutting position of the material upon completion of the acceleration ramp and no overswing or oscillation will take place prior to the cut. This saves time and increases the cutting efficiency of the shear system considerably.

3. Hardware Configuration

As a master drive, mostly the motor of a feed roll is used. The "master" can also be a measuring wheel equipped with an incremental encoder. **The encoder resolution should be at least 5 times higher than the maximum acceptable cutting error.**

Quadrature encoders (TTL-types A, \bar{A} , B, \bar{B}) must be used. Where you find you must use 24V encoders with A/B output, please apply our level converter type PU202 to generate the proper RS422 signals required.

Digital feed forward technology needs a certain minimum frequency: At maximum line speed, the master encoder frequency should be at least a few hundred Hertz. It is best to choose the ppr numbers of line and carriage encoders in a way to produce frequencies in the same range.

It is necessary to adjust the slave to it's maximum dynamic response (no internal ramps, no integral control loop, high proportional gain etc.) because the FS 150 will generate ramps to which the drive must follow with no additional delay..

A signal must be available to indicate completion of a cut to the FS 150 controller. All control signals must be PNP (switching to positive) with a level of 18....30 volts DC. Fig. 2 shows the block diagram of the unit.

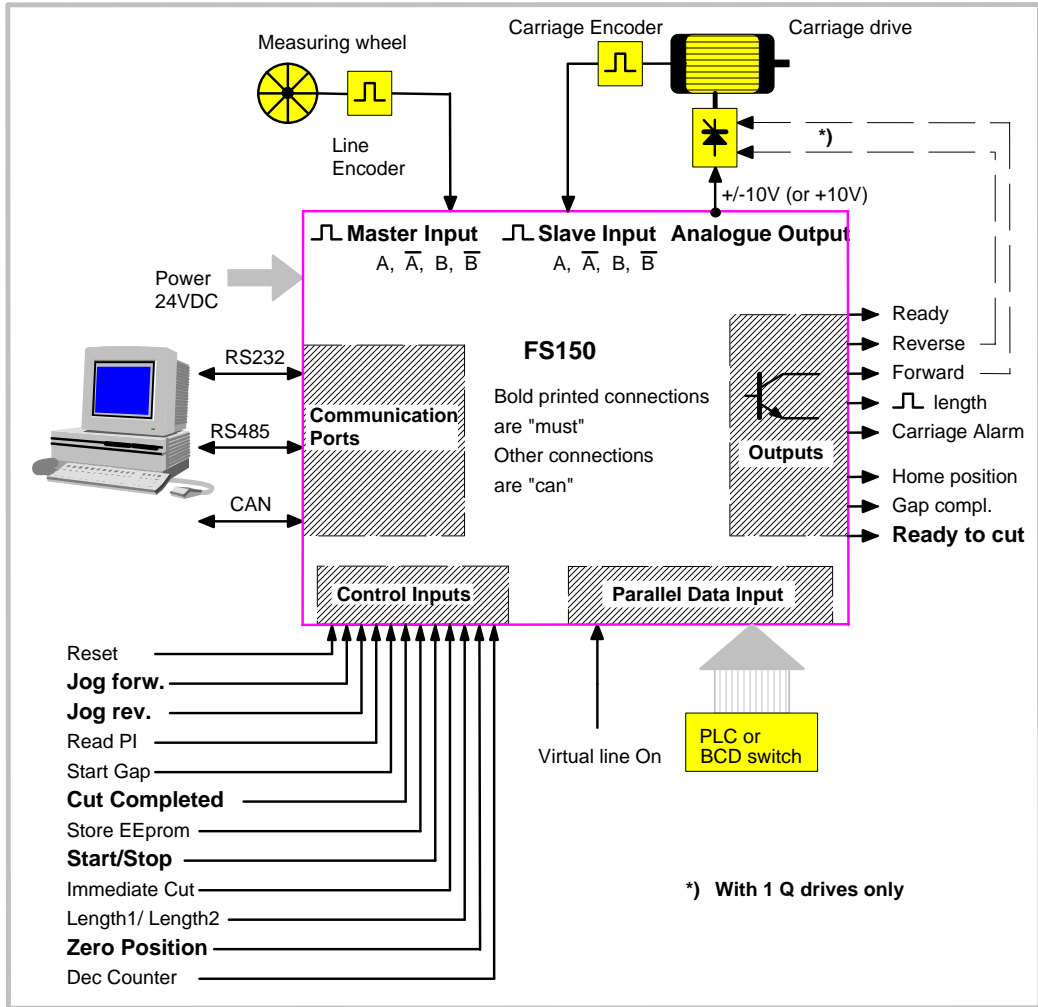

Fig. 2

For safety reasons, we strictly recommend to limit the travelling range by mechanical limit switches at both ends in order to avoid damage with carriage overshoot upon failure of the electronic control system!

4. Wiring and Screening

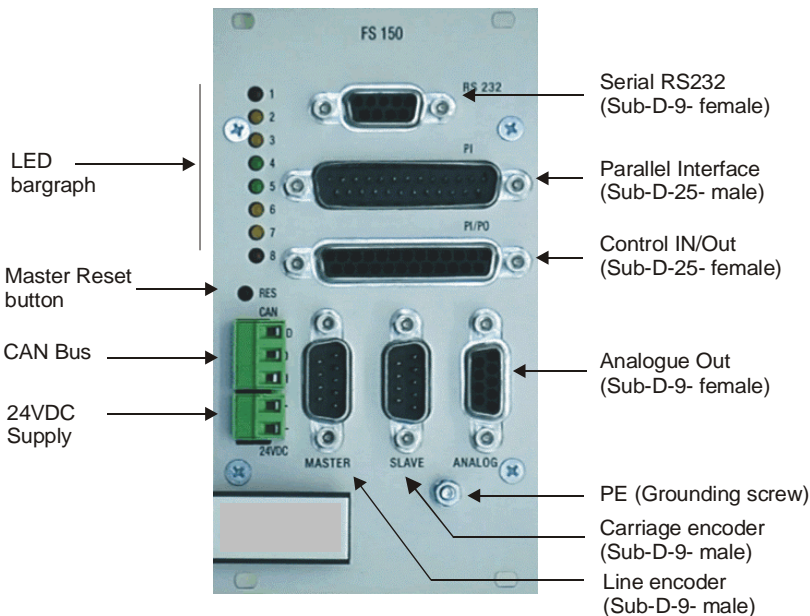

Fig.3

For reasons of proper screening, it is a must to follow the subsequent instructions.

Where you don't exactly observe these grounding and screening rules, it is almost for sure that you will have problems later!

- a. The minus wire of the power supply must be connected to the grounding screw on the front plate of the FS150 controller with a short wire of at least 0.75 mm².

On site of the power supply, the minus output must be earthed.

Where the wires between power unit and FS150 controllers are longer than e.g. 1 meter, it is advisable to ground the front plate of the controller again by a separate wire, on the shortest way possible.

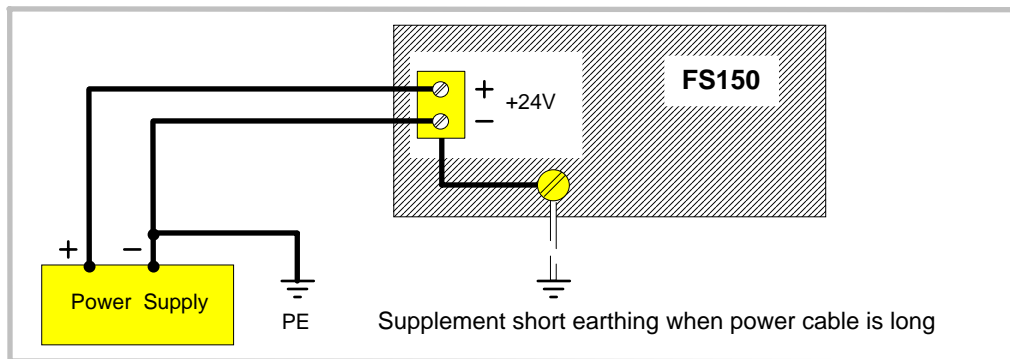

Fig.4

- b. All screens on the controller side must be connected to the housing of the corresponding Sub-D-connector. This is valid for encoder cables, analogue output and PI or PO lines. Where you use Sub-D-connectors with a plastic housing, you must solder the screen to the metallic frame of the connector. **At any time you must be sure the screen gets a proper contact to the front facia of the unit when connected to the controller.**

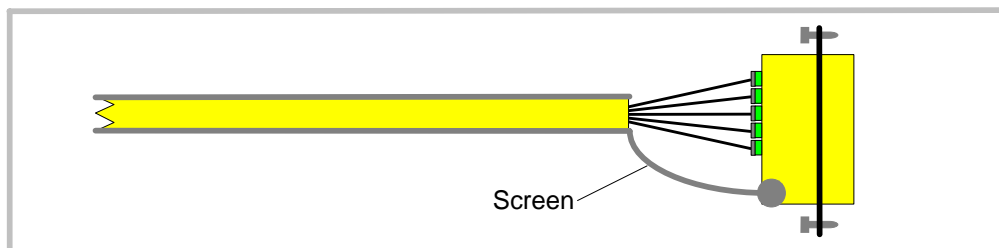

Fig.5

- c. When **encoder cables** are interrupted by terminal boxes or intermediate connectors on their way from the controller to the encoder, you must connect the screen to the Minus wire of the encoder supply there, but never to earth potential again!!.

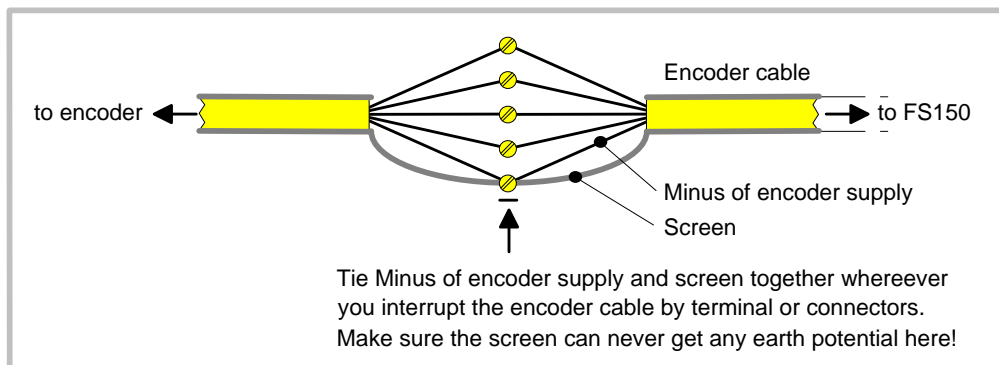

Fig.6

- d. When the cable arrives at the encoder site, the screen must again be connected to the Minus wire of the encoder supply, but not at all grounded to earth. In general, there are two types of encoder connections:

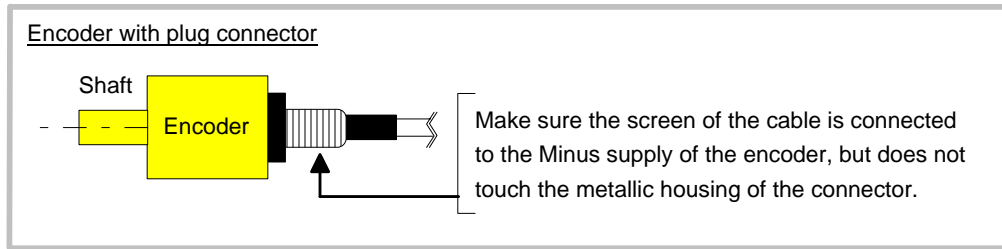

Fig.7

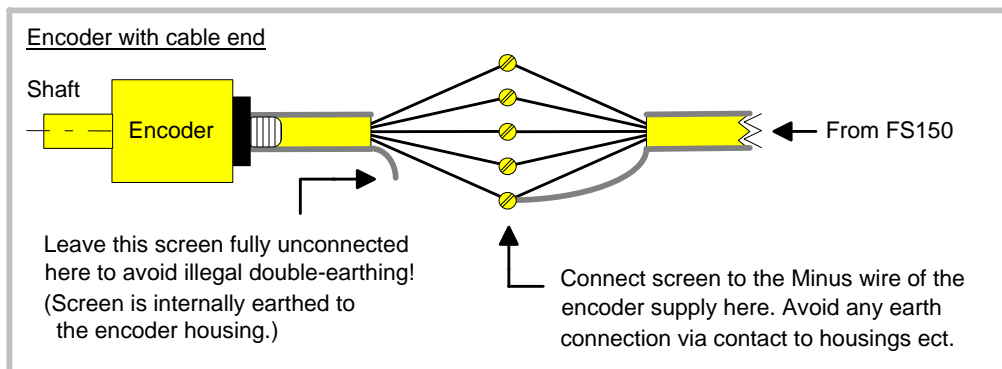

Fig.8

- e. With **all other cables** like analogue output, control or parallel output, put the screen to the metal connector housing on the FS150 side and leave it **unconnected on its peripheral side**. Again avoid double earthing. The only place where the screen is earthed must be the front plate of the unit!

Example : Analogue speed reference signal

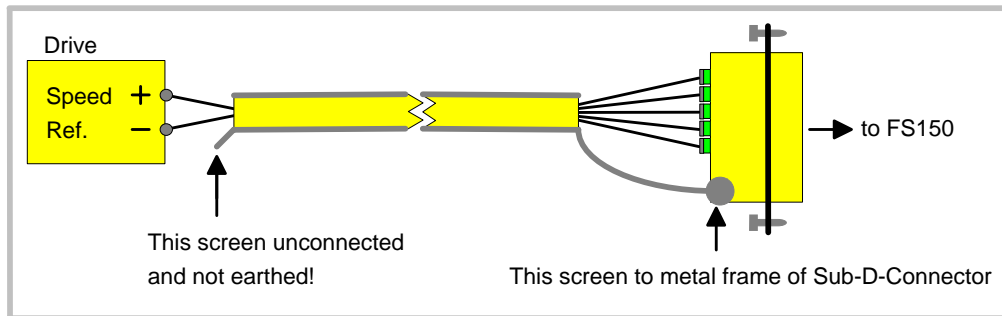

Fig.9

All cables connected to the FS150 should be separated from motor cables and other power lines. It is indispensable to use screened motor cables.

4.1 Encoders

The unit only accepts TTL impulse signals (5V, RS 422) or similar from an encoder simulation (resolver). It is essential to connect the channels A, \bar{A} , B, \bar{B} : The index inputs Z and \bar{Z} are not used with this application.

Where you find you are working with existing 10 - 30 Volt encoder signals which feature only A/B signals, the PU 202 converter should be used to gain full complementary signals in line with RS 422 standards.

An auxiliary voltage of **5,5 V (max. 500 mA)** is available on the connector plugs “**Master**“ and “**Slave**“, for easy supply of the encoders. Both connectors on the unit are Sub - D - 9 pin, male.

Fig. 4 and Fig. 5 show the encoder connections and the principle of the input circuit. All impulse inputs are isolated by high speed optocouplers.

When connecting the encoders it is not too important to wire the A and B signals to produce the correct counting direction. The direction can be determined in the setup menu.

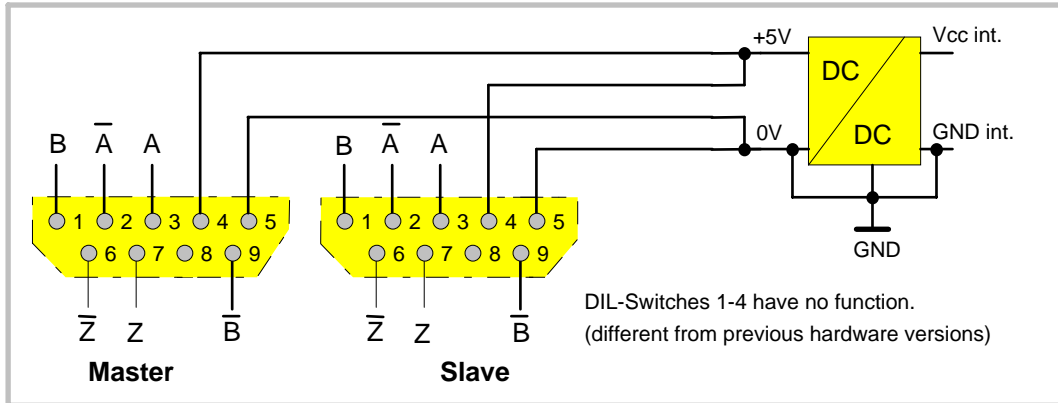

Fig.10

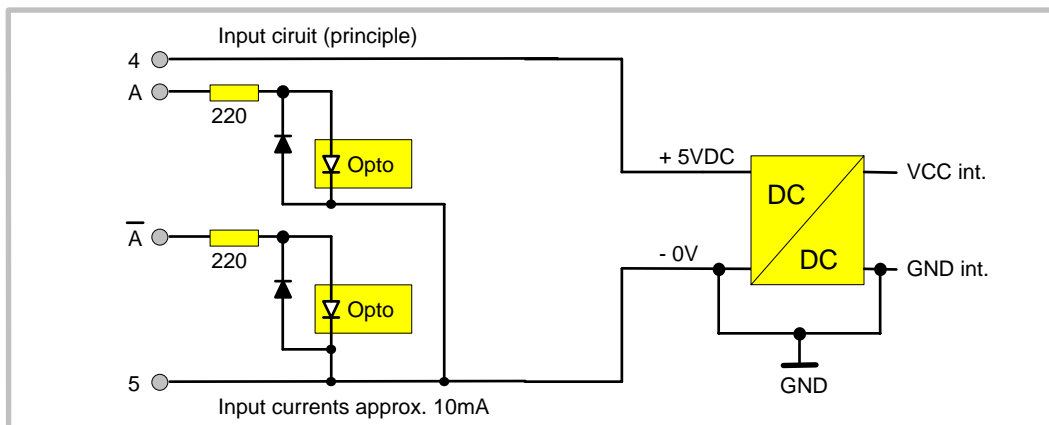

Fig.11

Important

- **With encoders, supplied by the FS 150:**
Connector pins 4 and 5 provide the encoder supply.
- **With encoders, supplied by an external source, or when an encoder simulation from the drive is used (Common GND operation)**
Use connector pin 5 as common zero Volt potential.
- **For fully potential-free operation:**
Connect **only** A, \bar{A} and B, \bar{B} and **leave terminal 5 (Common) unconnected.**

For reason of best noise immunity, we recommend to use potential- free operation wherever you have line driver signals with remote supply.

Warnings:

- You must ensure that no external voltage is applied to pins 4 and 5 as this can cause serious damage to the unit!
- Where you use one common encoder for feedback of the drive and feedback for the FS150 at the same time, there may come up interference problems. You can use a GV150 impulse splitter to eliminate any kind of problems. In most applications, the common encoder would also work fine when it is supplied by the drive and the FS150 operates in fully differential mode like shown.

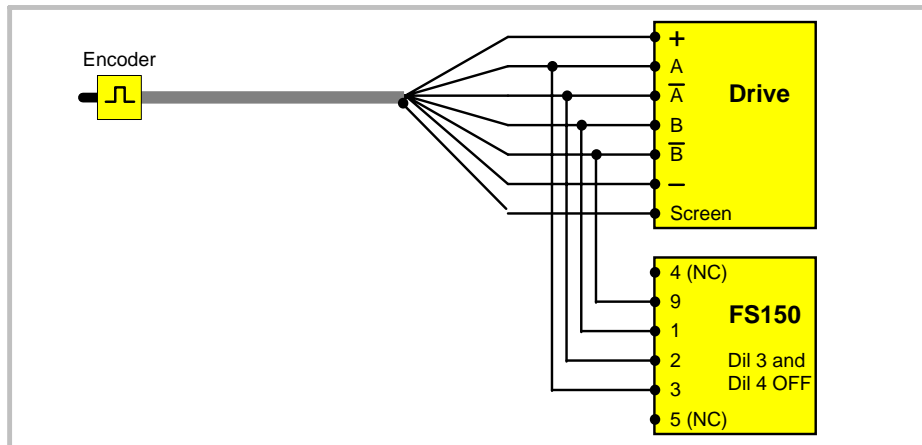

Fig.12

DIL switches S1 / 5 - 8 provide the selection of the **encoder edge counting**. It is possible with complementary signals to count with times 1, 2, or 4 without any fear of miscounting. The selection always applies separately to the master **and** the slave input signals.

Master:		
DIL-Pos. 5	DIL-Pos. 6	edge count
ON	ON	x1
OFF	ON	x2
ON	OFF	x4
OFF	OFF	counter disabled

Please note, that

Slave:		
DIL-Pos. 7	DIL-Pos. 8	edge count
ON	ON	x1
OFF	ON	x2
ON	OFF	x4
OFF	OFF	counter disabled

- the maximum frequency of the FS150 refers to the total **number of edges** counted, i.e. 300 kHz (x1) or 150 kHz (x2) or 75 kHz (x4).
- impulse numbers, to be entered upon setup, also refer to the total **number of edges** counted, i. e. the entry data must be doubled with (x2) etc.
- When possible, you should set the switches in a way to produce approximately similar impulse numbers on Master and Slave side to achieve best operation. i.e. 4096 impulses x 1 on the Masterside and 1000 impulses x 4 on the Slave side. The **cross section** of encoder cables must be chosen with consideration of voltage drop on the line. The FS150 provides a 5.5 V encoder supply and at the other end the encoder must at least receive it's minimum supply voltage! (See encoder specifications).

4.2 Analogue Output

The analogue connector (Sub-D-9 female) provides several auxiliary lines that are not applicable with FS150 functions. The only pins that must be connected are pin 2 (GND) and pin 7 (output). The cable must be screened and the screen must be connected to the connector housing on the FS150 side. **The screen must be unconnected on the drive side!**

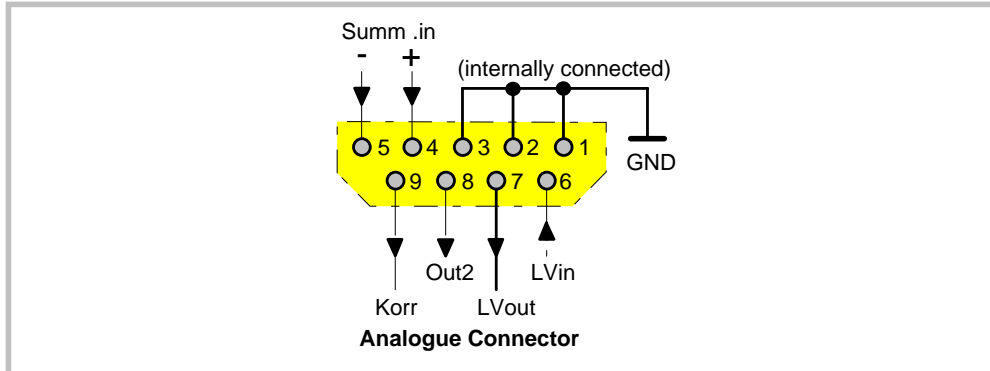

Fig. 13

4.3 Power Supply

The FS 150 operates from an un stabilised 24 VDC supply (+/- 25%), however, the voltage including ripple should not exceed the following limits (18 V...30 V). The supply of the FS 150 is both electrically and mechanically protected against wrong polarity misconnection by protection diodes and a special plug.

Warning:

At pin 1 of the "PI" connector and pin 1 of the "PI/PO" connector, a polarity protected + 24 V supply is available for various purposes. Keep these lines strictly separated from the + 24 V power supply.

When these lines come together, the electrical polarity protection would be bypassed and any incorrect polarity on the unit's power input would cause definite and irrecoverable damage!

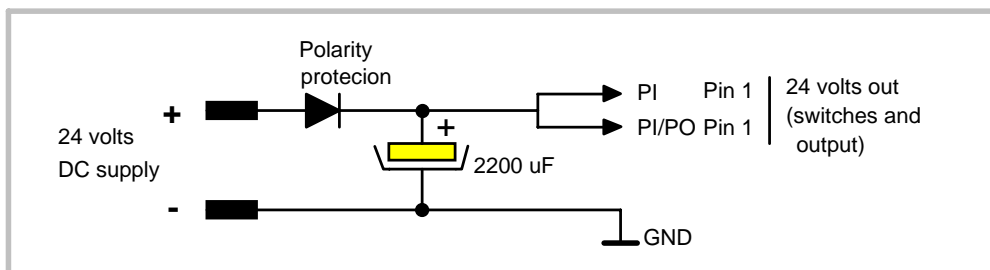

Fig. 14

4.4 Parallel Interface

The interface provides remote setting of operational and configuration registers. It receives BCD or binary data (selectable) from a remote thumbwheel switch or PLC control. There are three binary coded select lines which provide 8 addresses being accessible, via 20 data lines. The register parameters are stored in the following manner:

- a. Read and activate parallel data upon a strobe pulse. The data is then transmitted to the internal RAM and activated immediately.
- b. Store the data to the EEPROM by a Store pulse, when you like the unit to use same data again after power down.

It is easy to see how 8 external registers may be loaded into the BY 150. For operation of Read and Store inputs see section 4.5.

The connection of the parallel interface is a 25 pin Sub-D connector (male) which is marked as "PI" on the front facia.

All inputs are PNP switching and fully PLC compatible. All signals refer to GND and the minus potential of the supply.

Logic 0 (low)	=	0.....8 Volts
Logic 1 (high)	=	18...30 Volts

Important Advice

Upon power up, the unit loads the full register set stored in its EEPROM. Data transmitted from the parallel and/or serial interface will overwrite the operational RAM data, but not the corresponding EEPROM registers. As a result, when powering up, any parallel or serial data will be replaced by EEPROM data, until it is overwritten again.

The RAM data however can be restored to the EEPROM at any time by parallel or serial command.

Parallel interface operations must keep the following timing conditions:

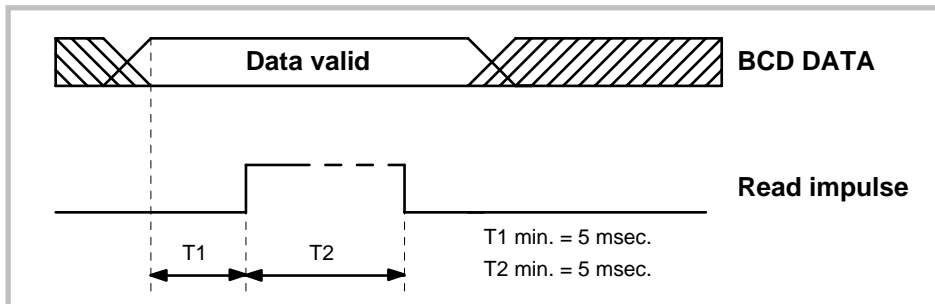

Fig. 15

Data latch occurs with the positive transition of the strobe pulse. Data lines must be in a valid state at least 5 msec prior to the strobe, and remain present for an additional 5 msec while the data is read. There is no upper limit for T1 and T2.

Mostly the parallel interface is used to preset the cutting length by a simple remote BCD thumbwheel switch or by a PLC parallel output. The select lines S1-S3 allow to preset also other registers like shown in table above. Registers are described later in this manual.

Pin 3 of the PI parallel interface provides a special control function:

A "virtual line axis" can be switched on by this pin, allowing to fully operate all carriage functions without material and with the measuring wheel in standstill. This is useful for testing and commissioning. More details are to be found in the section "Virt. Line".

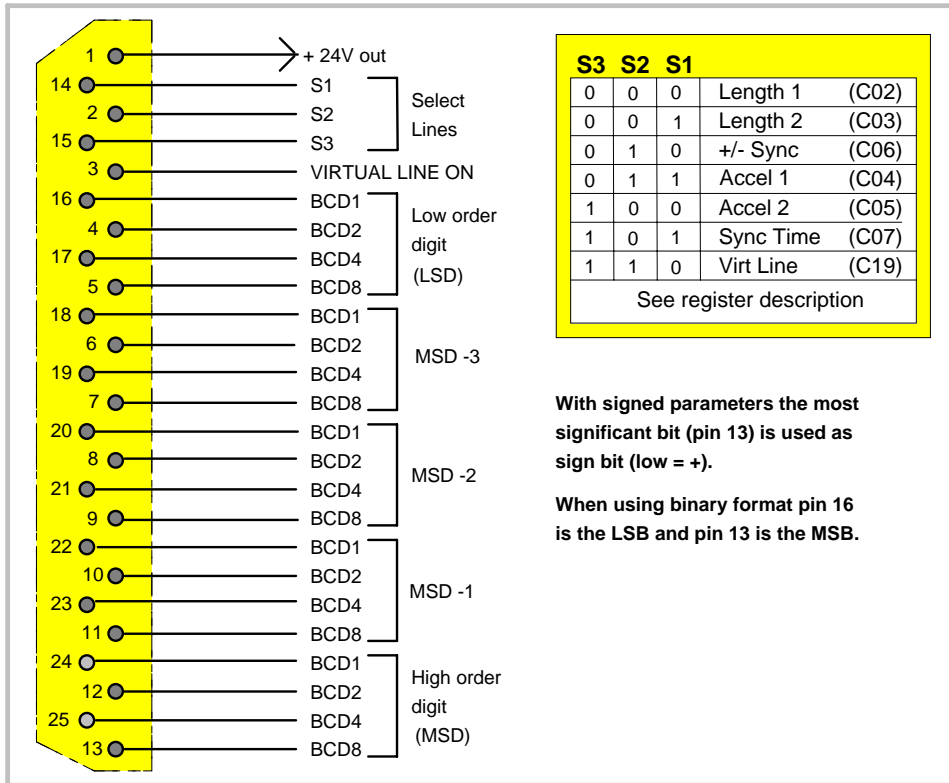

Fig. 16

5. Control IN / OUT Port (PI/PO)

There are 12 input lines and 8 output lines for remote control purpose.

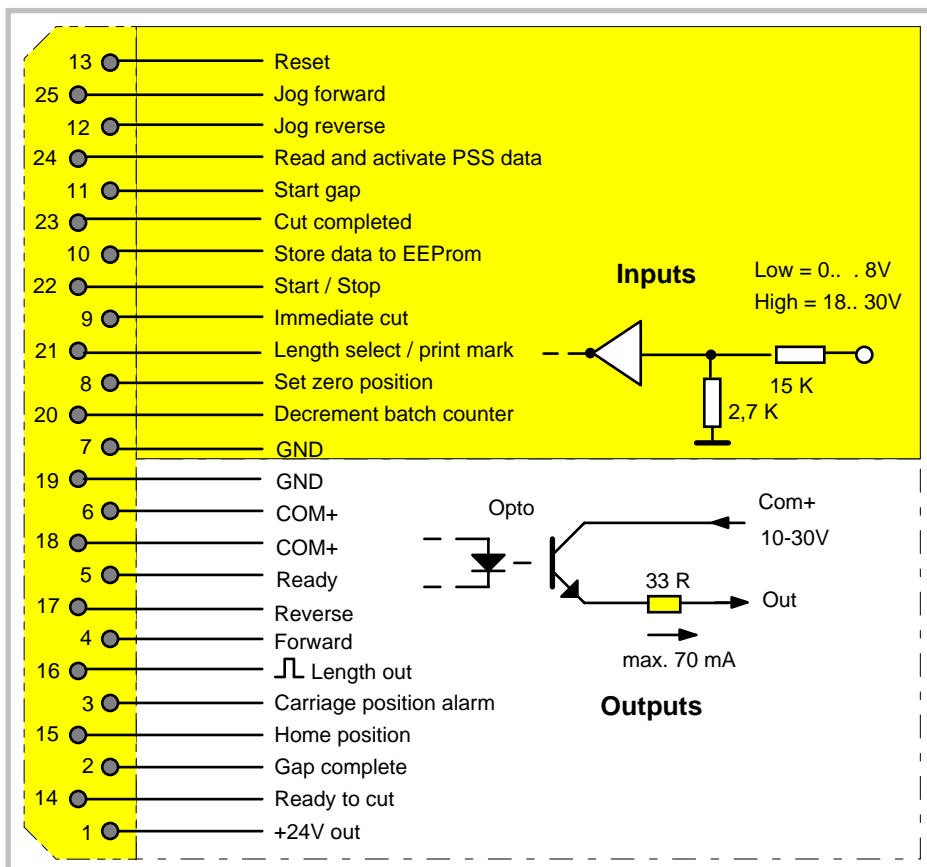

Fig. 17

Inputs:

Reset (13):

When set High, a new initialising cycle is started and error messages will be cleared. Reset does not affect any carriage position counters or batch counters.

Jog forward (25) / Jog reverse (12):

Moves the carriage in one or the other direction (Jog speed register settable). The carriage automatically stops when it reaches one of the software limit switches (Minimum or Maximum position). Jog inputs are only active when the Start/Stop input is in stop state. The software limit switches do not operate while you keep the "Teach Zero" input high. Whenever the Jog command is released, the shear will be electrically hold in it's new actual position and start from there to execute the next cut.

Read and activate data (24):

Reads data from the parallel interface and activates new data in the cutting process.

Start gap (11):

Upon completion of the cut it is possible to shortly accelerate the carriage, so the tool will shift forward the material and make a gap between. The size of the gap is register settable and an output will signal when the gap is completed. Leave input unconnected when gap function not used.

Cut completed (23):

This input must receive a signal when a cut has been completed. The direction of the signal (High/Low) is register selectable. With the selected edge the FS 150 will start deceleration and reversal in order to put the carriage back to it's rear home position. Each cut completed signal will increment the batch counter.

Store EEPROM (10):

A High signal on this input will store all register data to the EEPROM. Data which have been transmitted by the parallel interface will be lost after power down, unless this input has been activated prior to power down. The EEPROM has a limited number of 100.000 store cycles during it's life time.

Start / Stop (22):

When low, the automatic cutting cycle will be interrupted, but the Jog functions and the Immediate cut input will remain active. When high, the carriage will continuously execute cutting cycles according to the preset length.

Immediate cut (9):

A positive edge at this input will immediately start the shear for a cutting cycle, independant on what the actual length is. The sub-quent cut will correspond to the preset length again, unless a Flying Cut has been triggered again.

This function i.e. allows the operator to cut out bad parts of the material. Immediate cut commands will increment the waste counter.

Length select / print mark:

This input provides a double function:

With **Mode 1** (normal operation without print mark), this is a length selection. Since the unit stores two cutting lengths (Length 1 and Length 2), a low at this input selects Length 1 to be cut while a High at this input selects Length 2.

With **Mode 2** (operation with print marks), this is the input for the sensor or photocell detecting the print mark.

Set Zero position (8):

This input allows to define the "Zero" position of the carriage. The internal carriage position counter is Reset to Zero while this input is High. All limitation settings and alarms refer to this zero position. Please note that upon power up the carriage position counter will be cleared also, and the unit would take any actual position as a Zero position. Where you power the controller down while the carriage is not in at Zero, or where you move the carriage with the controller in powerless state, it is always necessary to redefine "Zero" after power up by a positive signal to this input.

Decrement batch counter (20):

The unit provides an internal batch counter incrementing by one with each cut. If for any reason one cutted piece cannot be used (waste), the counter can be decremented by a positive edge to this input, to match the real number of usable products.

Outputs:**Ready (5):**

A high signal indicates the unit is ready to operate and a low signal indicates the unit is out of order or an error has been detected and the unit has switched off the control loop (see "Errors"). When high, the unit could not detect a fault by itself, but this is not a guarantee that the whole system is ready to work.

Reverse (17) / Forward (4):

Where you use a carriage drive with only positive speed reference and digital forward/reverse select, these two outputs will control the direction of rotation. The output goes High when the corresponding direction is required.

 \square Length out (16) :

This output generates impulses proportional to the line motion with scalable length units. As an example, it might be used to totalise full meters of material passing through, by a separate counter or PLC.

Carriage position alarm (3):

This can be used to limit the travelling way of the carriage into forward direction during production.

If, i.e., for mechanical or other reason, the carriage could not synchronise with the line, the controller would never generate the „Ready to cut“ signal and the carriage would run to the front detent. The alarm position is register settable and this output switches High to indicate the carriage will run out of range if not broken down immediately.

Carriage home (15):

A high state of this output indicates the carriage is in it's home position like defined by register "home window".

Gap complete (2) :

When the gap function is used, a high signal indicates that the gap has been executed and the controller now waits for the "cut completed" input.

Ready to Cut:

This output goes High when the shear has reached it's cutting position with respect to the material and moves fully synchronous with the line. See parameter "Cut window". It goes Low again when the shear signals "Cut completed".

Important remarks:

1. When for any electrical or mechanical reasons the carriage cannot reach the proper cutting position or cannot synchronise with the line speed, the "Ready to Cut" signal will never switch on and the carriage could run to its front detent without executing a cut! Use the Carriage alarm output and mechanical safety switches to avoid damage.
2. Each cut must be followed by a "Cut completed" signal, otherwise no reversal of the carriage will take place and it will run to its front detent! For tests (with saw blade or shear removed) it is legal to connect the "Ready to cut" output to the "Cut completed" input.

6. The Serial Port

The RS 232 serial link can be used for two purposes:

The unit includes a serial RS232 and a RS485 interface, both accessible by the Sub-D-9 connector marked „RS232“.

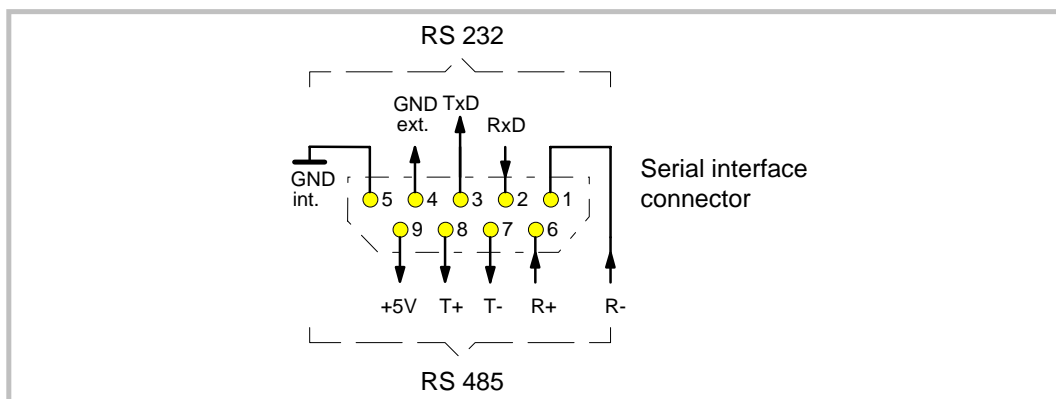

Fig.18

To run the OS 3.0 operator software with your PC by RS232, your PC must be connected to the FS150 unit like shown:

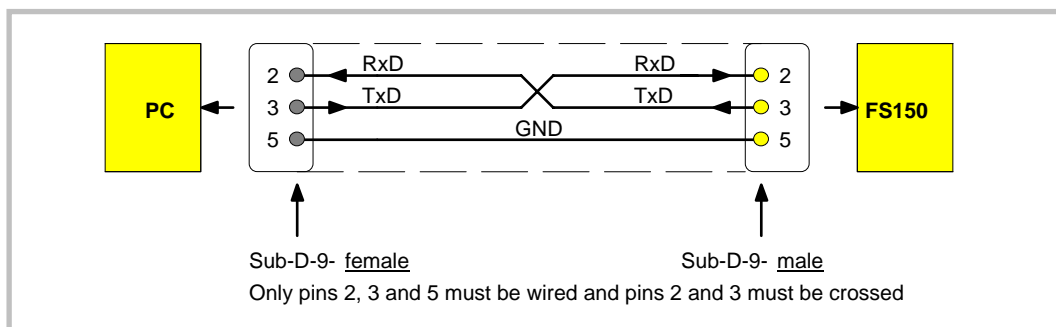

Fig.19

Please make sure your PC serial cable uses only the three pins shown. When also other pins are connected, this will cause interference with the RS485 pins and the PC communication will not work.

When using the RS485 interface, you can serve up to 32 different bus participants in either 2-wire or 4-wire transmissions mode. The subsequent figures show, as an example, how to run a TX720 operator terminal with a FS150 unit and other controllers.

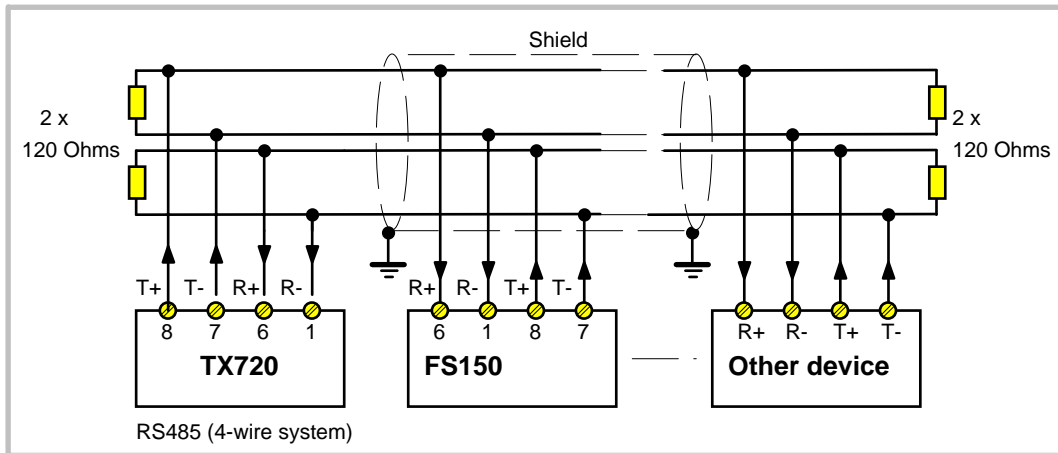

Fig.20

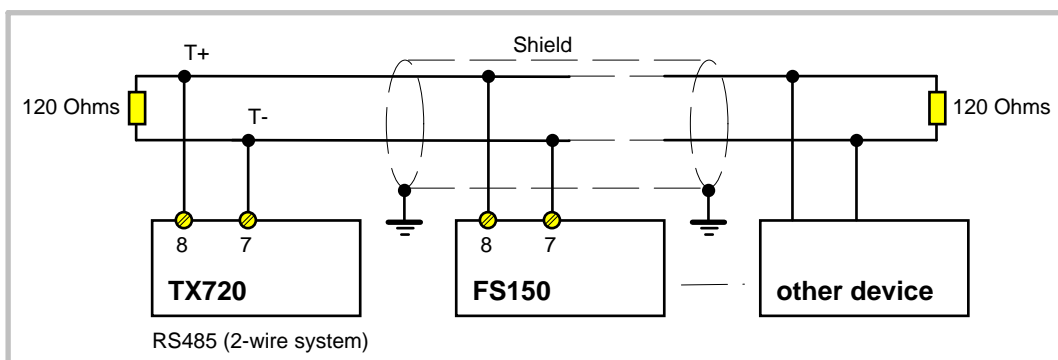

Fig.21

A detailed **description of the serial protocol** is available upon request or can be downloaded from the Download site of the motrona homepage (www.motrona.com, document name: „Serpro“).

7. Register settings

Registers can be set by keypad under LCD control or by PC, using the OS30 operator software. This section describes the registers and their meanings and the next section shows how to program the registers.

The unit provides 4 Sub-Menus.

Data In Contains operational registers.

Setup Contais registers that need to be set only once upon commissioning.

Adjust provides easy setting of the analogue gains upon commissioning.

Test prog executes various testing functions for internal and external signals.

Expressions like C00 indicate the serial register access codes.

		B ← → A					
	Data In	Set - up		Adjust	Testprog		
	C00	Pulses Line/1000	C40	Mode	Gain - Cor	Mast-Dir	
	C01	Pulses Cut/1000	C41	1Q/4Q	Gain - Tot	Slav-Dir	
	C02	Length 1	C42	PI-Format		Offs-Cor	
	C03	Length 2	C43	Add-Correction		Gain-Cor	
	C04	Acceleration 1	C90	Unit-Number		Offs-Tot	
	C05	Acceleration 2	C91	Baud- Rate		Gain-Tot	
	C06	+/- Synchron Rate	C92	Serial Format		Led + PO	
	C07	Synchron Time	C93	Bus-Add		Cont. in	
	C08	Tool Width	C94	Bus-Baud		PI in	
	C09	Integration Time	C95	Bus-Config		Ind-Mast	
	C10	Cut Window	C96	BusTxPar		Ind-Slav	
	C11	Gap Length	C97	BusRxPar		DAC-Cor	
	C12	Gap Time	C45	Master Direction		DAC-Tot	
	C13	Edge Sense	C46	Slave Direction		Factory	
	C14	Jog Speed	C47	Offset Correction			
	C15	Jog Ramp	C48	Gain Correction			
	C16	Home Window	C49	Offset Total			
	C17	Minimum Position	C50	Gain Total			
	C18	Maximum Position					
	C19	Virtual Line Speed					
	C20	Photo -> Cut					
	C21	Dead Band					
	C22	Return Window					
	C23	Return Speed					
	C24	Sampling Time					
	C25	Alarm Preset					
	C26	Length / Pulse					
	C27	Scaling Length					
	C28	Power Sense					
	C29	Ramp Form					
C30	Sync Samples						

Fig.2

2

Prior to register setting you must decide with which dimensions or units you like to preset the cutting length. This could be 0.1mm or 1mm or 0.001 inch or any other resolution you desire. All further settings refer to the length units you decided to use. When i. e. you choosed to set the length with a resolution of 0.1mm, 1000 length units will be 100 millimeters and you must preset the length in a format like 100.0mm.

Pulses Line:

This register calibrates the encoder ppr of the **line encoder**. You must find out how many impulses we receive when the line moves **1000 length units** forward. Set the number of impulses to this register.
Range 0-999 999

Pulses Cut:

This register calibrates the encoder ppr of the **carriage encoder**. Setting is similar to the Pulse lines register.

Length 1 / Length 2:

These registers contain your cutting lengths. Enter a default length here.

Clarification: You can preset two length and the remote signal “Length select“ will decide whether we cut length 1 or length 2. Upon power up, the unit will load the length set to these registers. Data transmitted by parallel or serial interface will overwrite the registers. Parallel or serial data will be valid until the next power down only, unless they have been stored by a “Store to EEprom“ command.

Acceleration 1: Acc/Dec rate for forward motion of the carriage, scaled in **length units/sec²**.

Acceleration 2: Acc/Dec rate for reverse motion of the carriage, scaled in **length units/sec²**.

Remarks to acceleration settings

- The ramp times for acceleration and deceleration result from the setting and from the speed. Where you use length units of entire millimeters and you set Acceleration to 10 000 mm/sec², the unit would accelerate the carriage within one second from standstill to 10 m/sec which is 600 m/min. This means it would take 100 msec to go from standstill to 60 m/min etc.
- Acceleration values must be set in a way that motor and drive can follow the ramps generated by the controller. Setting values outside the physical range of the drive system result in malfunction or failure of the whole system.

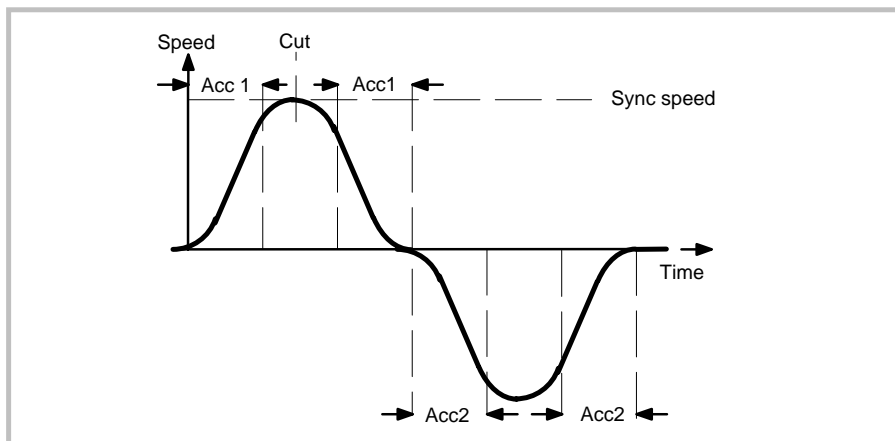

Fig.23

+/- Synchron Rate:

This register allows to slightly vary the synchronous speed in a range of +/-9.99%. In general, this register will be **set to 0.00** and the carriage will synchronise with the line exactly according to the encoder information.

Some applications with extrusion lines need to adapt the sync speed, because the material is hot and cools down on the way between the measuring wheel and the cutting position. This will cause shrink which can be compensated by the +/- Synchron Rate register. It affects the synchronous speed but not the length.

Synchron Time:

This is an adjustable delay time between reaching the synchronous speed and switching on the “Ready to cut“ output. Setting range 1-9999 milliseconds. Under regular conditions the carriage will be in the correct cutting position immediately after completion of the acceleration ramp and the Sync Time register can be set to it’s minimum value of 1 msec. With mechanically unstable carriage con-structions it may however be applicable to leave a short stabilisation time before activating the cut.

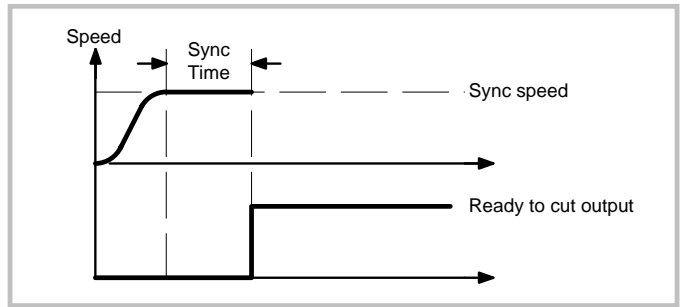

Fig.24

Tool width:

Provides compensation of the width of the saw blade or cutting tool. Setting 0-999 length units.

Integration Time:

Sets the integration in order to avoid cutting errors caused by non-linearities of the carriage drive.

- 00 = Integrator off
- 01 = Fast integration
- 99 = Slow integration

For setting see section "Steps for commissioning".

Cut Window:

Sets a tolerance window around the cutting position where the carriage must be before the "Ready to cut" signal is switched on. Setting is directly in number of increments of the carriage encoder. Range 1-99 increments. We recommend to set this window not too small, because no cut will be activated when for any reasons we do not reach this window (carriage will run to the front limit).

Gap Length:

In some applications it is desirable, after the cut, to shortly accelerate the saw blade in order to shift the cutted piece forward and produce a gap prior to removing the tool from the line. The gap can be set directly in length units, range 0-9999. **In most applications, this function will not be used.** To use the gap function, the following timing of signals must be observed:

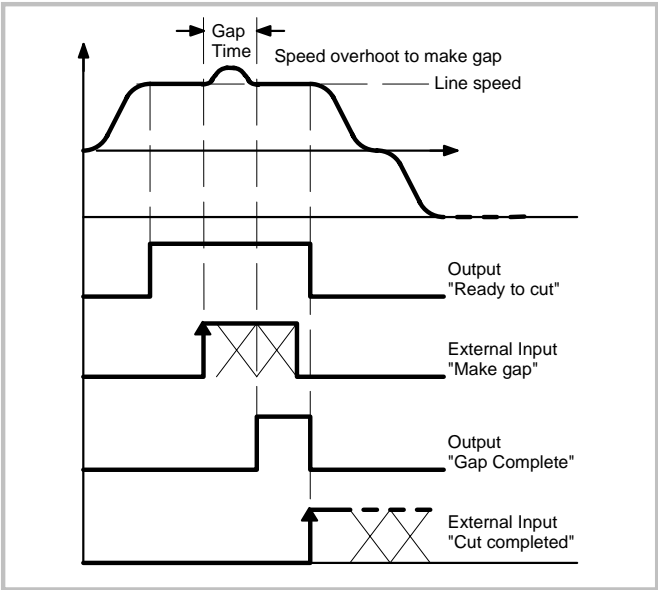

Fig.25

When the gap function is not used, the input "Make gap" remains unconnected, but at any time the signal "Cut completed" must be applied to start the return process of the shear.

Gap Time:

Time in milliseconds to make the gap. Range 1 - 9999 msec.

Edge sense:

Sets the active edge for the external "Cut completed" signa

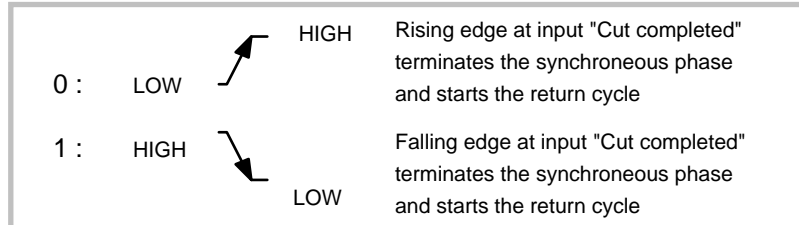

Fig.26

Jog speed:

Sets the carriage speed when one of the "Jog forward" or "Jog reverse" inputs is active. The setting range is 0.00 to 9.99 Volts of speed reference for the slave drive.

Jog Ramp:

Ramp time for Jog operation, dependant on selected jog voltage:

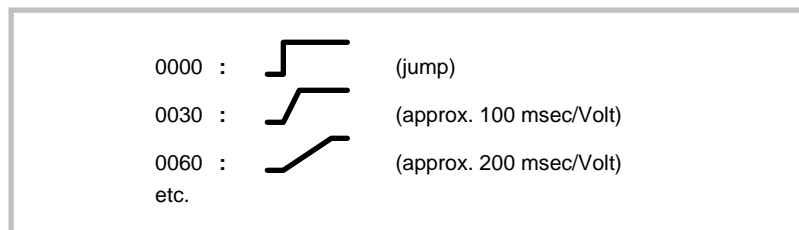

Fig.27

Home Window:

Sets a window around the home position of the carriage. Setting in length units 1-9999 units. The output "Carriage home" is high when the carriage position is inside this window. The unit will go to **Alarm state** when a new cutting cycle will be started before the carriage has returned to the home window from the previous cut.

Min Position Max Position:

Programmable software limit switches for the extreme forward and rear carriage position. Setting is in length units and the range is from -999999 to + 999999. The setting refer to the "Zero" Position which is set by the "Zero Position" input. In general (but this is not a "must"), the Zero position is also used as the "Home" Position. In this case, the Min Pos must always be set to negative and the Max Pos must always be set to positive values. When the Start/Stop input is in Stop state, these two software limit switches will limit the travelling range with Jog operations.

When we are in Start state (automatic cutting), only the rear limit switch will stay active and cause the unit to go Alarm state when touched. The maximum position switch will not work, but instead the "Carriage Alarm Preset" will control the maximum forward position of the drive.

The following drawings assume we have set our Minimum position to -20mm, our Maximum position to 2500mm and our Carriage Alarm to 2000mm.

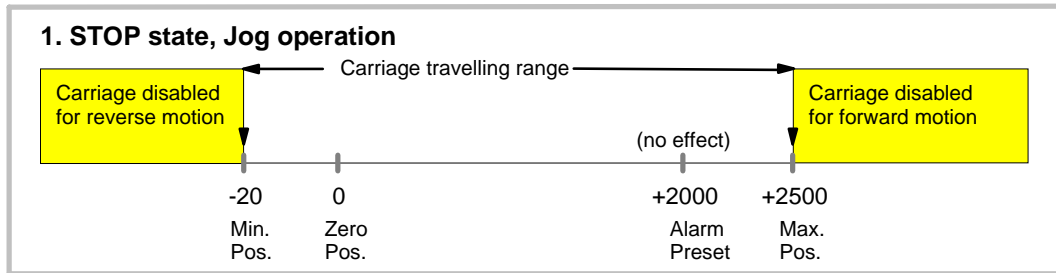

Fig.28

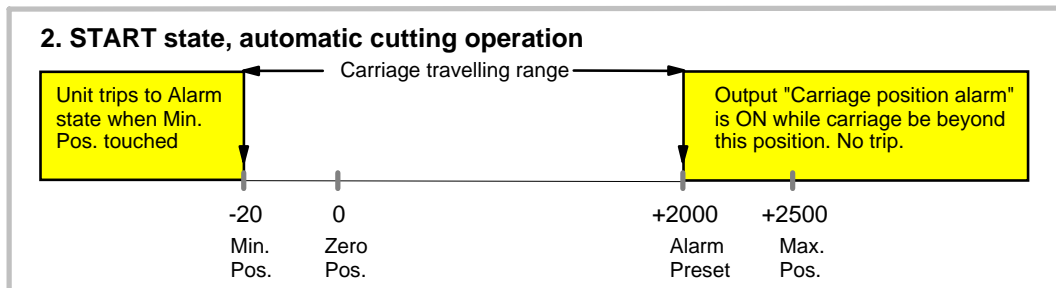

Fig.29

Please note that for “Home” the unit uses the position where the carriage is while we switch the Start/Stop command to Start, i.e. “Home” and “Zero” can be different positions!

Virt Line Speed:

Virtual speed to simulate the motion of the line. Setting as “Length units per minute“. With a scaling of full millimeters, setting of e.g. 20.000 means 20m/min.

When the virtual line is switched on, the controller simulates the motion of the measuring wheel. To switch the simulation on:

- Have the carriage in it’s home position
- Have the Start/Stop input Low (Stop)
- Now apply a positive transition to pin 3 of the parallel interface and keep it High.
- Set the Start/Stop input to High (Start) to run the machine with the virtual speed.

Photo →Cut *):

Distance between photocell and home position with print mark tracking. Setting 0-999 999 length units.

This register is only operative in Mode 2 (print mark registration). Please note the print mark sensor must be mounted in a way that never more than 8 print marks appear between the sensor and the carriage home position. The FS150 controller can store up to 8 print mark positions in a FIFO shift register and cut accordingly . The unit trips to Alarm state when more than 8 print marks are detected between the position of the photocell and the carriage home.

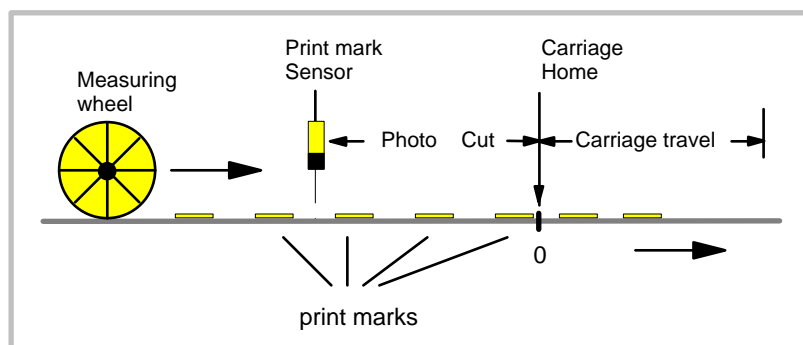

Fig. 30

Dead Band:

For use with 1-quadrant inverter drives only: Provides a delay between the forward output signal and the reverse output signal to avoid overlapping of the for/rev select. Adjustable in milliseconds. Range 0 - 9999msec.

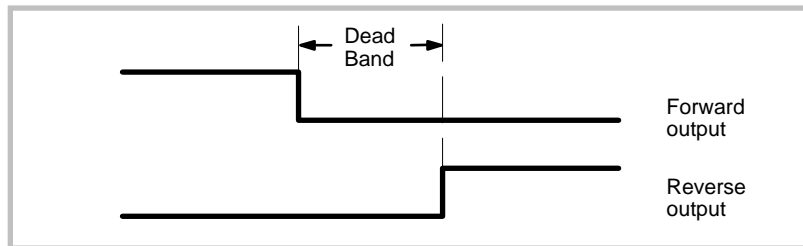

Fig.31

Return Window:

Applicable when 1-Q inverter drives are used as carriage drive. Since these drives do not have any torque in standstill, they tend to slightly overshoot when moving back into the Home position. I.e. the carriage comes to a stop a few millimeters beyond the scheduled position.

Return window is scaled in length units and compensates for overshoot by starting the deceleration ramp earlier.

Return Speed:

Sets the ratio between the actual line speed and the maximum return speed. Range 0.01 - 9.99. Setting 2.00 says that, if necessary, the return speed can take the double amount of the actual line speed.

Sampling Time:

Provides digital filtering of the feed forward signal generated from the line encoder. Range 0001 - 9999 msec. Normal setting **1 msec** recommended.

In applications where the line speed is very unsteady, settings like 10 or even 100 msec can be advantageous for smoother motion of the carriage. Please note that higher setting results in lower response with changes of the line speed.

Alarm Preset:

Sets an alarm position for the forward motion of the carriage and switches on the alarm output when exceeded. See also "Min/Max Position".

If for any reasons the unit cannot switch on the "Ready to cut" signal, the alarm output can be used to prevent the carriage to run to the mechanical front end. You should set the preset position in a way that there is still space to break the carriage down to standstill before we reach the detent. Setting range 0 - 999 999 length units.

Length/Pulse:

Scaling factor for the auxiliary impulse output. Setting range 1 - 99 999 length units per impulse. If the whole system is calibrated in "Millimeters" and the output should be used to count and totalise the line with full meters, set this register to 1000 to receive one impulse every meter.

Scaling Length:

In some applications the real cutting length may be different from the cutting length set to the unit, due to some slip of the measuring wheel etc. As an example, the length setting could be 6000 millimeters and you find out the real cutting length is 6010 millimeters.

Where you find your real cutting length is different from your setting, enter the real cutting result here (i.e. 6010 mm) and the unit will automatically change the scaling to receive 6000 mm when you set 6000mm.

Attention: A new internal impulse scaling factor is calculated every time you take serial access to this register, and repeated access will raise this factor to higher power, which results in wrong scaling. Please write the value of the active cutting length into the register "Scaling Length" before starting the scaling procedure explained above. This ensures that the initial value of the internal scaling factor is 1.0000. The internal impulse scaling factor is **stored to EEPROM automatically**.

Power Sense:

0 = batch counters not stored in the EEPROM upon power down
1 = batch counters stored in the EEPROM

Ramp Form

Selects the shapes of the ramps of the carriage speed profile. Two types of ramps are available: linear and S-shaped (sine square) ramps. The selection can be made independently for each of the four ramps of the speed profile by setting the corresponding bit of the parameter "Ramp Form" either to 0 or to 1:

Bit 0:	forward acceleration ramp	Bit 1:	forward deceleration ramp
Bit 2:	backward acceleration ramp	Bit 3:	backward deceleration ramp

A ramp is an S-shaped ramp if the corresponding bit is 0 and it is linear if the corresponding bit is 1. Example: RampForm = 0 means that all ramps are S-shaped, RampForm = 15 means that all ramps are linear.

S-shaped ramps are recommended when using drives with high response (e.g. servo drives) whereas linear ramps are recommended for drives with lower response (e.g. big DC drives).

Sync Samples

Filter for the cut window. The purpose of this parameter is to ensure that the carriage has reached a stable position within the cut window and stays in this window after the "ready to cut"-output has been switched on. After reaching the synchron phase the FS150 controller continuously checks whether the carriage is in the cut window or not. Sync Samples = n means that the result of n consecutive checks must be positive (i.e. carriage in the cut window) before the "ready to cut"-signal is switched on.

This function should only be used for systems with poor dynamic performance. Please note that too high settings of this parameter will probably cause the FS150 controller to give no "ready to cut"-signal at all! Setting range: 1 – 9999, recommended setting: 1.

Mode: Operation mode.

1 = Cut to length without print mark
2 = Cut with print marks

1Q/4Q: Selects the type of the carriage

- 1: The carriage drive is a 4-quadrant drive moving forward with positive and moving reverse with negative speed reference voltage.
- 2: The carriage drive is a 1-quadrant drive using only positive speed reference voltage and selecting the direction of motion by digital inputs forward/reverse.

PI Format: Selects the entry code of the PI parallel interface:

0 = Data entry in BCD-code
1 = Data entry in binary code.

Add-Cor:

Must normally be set to "1" at any time. Setting to "0" switches off the digital control loop for testing purpose.

Unit NR:

Attaches a device number to the FS150 controller for serial communication. Setting from 11 to 99. It is not allowed to use device numbers containing a "0" (i.e. 09 or 20) since those are reserved for collective addressing of several units.

Ex factory, MOTRONA units use always Unit NR.11.

Baud-Rate:

For serial operation only. The following transmission rates can be selected:

0	9600	Baud
1	4800	Baud
2	2400	Baud
3	1200	Baud
4	600	Baud
5	19200	Baud
6	38400	Baud

Factory setting "0"

Ser-Form:

For serial operation only. The following formats of serial data can be selected:

Ser-Form	Databits	Parity	Stopbits
0	7	Even	1
1	7	Even	2
2	7	Odd	1
3	7	Odd	2
4	7	None	1
5	7	None	2
6	8	Even	1
7	8	Odd	2
8	8	None	1
9	8	None	2

Factory setting "0"

Bus-Add, Bus-Baud, Bus-Config, BusTxPar, BusRxPar:

Only relevant for units with option „field bus interface“ (CAN-Bus or PROFI-Bus DP). See supplementary instructions for further information.

Mast Dir :

Selects clockwise or anticlockwise rotation of the line encoder. For setting see section "Steps for commissioning".

Slave Dir:

Selects clockwise or anticlockwise rotation of the carriage encoder. For setting see section "Steps for commissioning".

Offs. Cor:

Sets the offset of the analogue correction signal. Range -99...+99mV. Must be set to 00 under regular conditions. See remark.

Gain Cor:

Adjusts the proportional Gain of the digital control loop. Practical settings are from 200 to 1000. See section „Steps for commissioning“.

Offset Tot:

Sets the offset of the total analogue output signal. Range -99.... +99mV. Must be set to 00 under regular conditions. See remark.

Gain-Tot:

Sets the Gain of the analogue feed forward signal to drive the carriage at correct speed. Range 0 - 999 999. For setting see "Steps for Commissioning".

Remark for offset settings:

FS 150 uses precision operational amplifiers with a zero offset error of less than 1mV and the offset register can be set to zero normally. With extended installations however, an offset voltage can build up in the cables, caused by small balance currents between the different devices. Where you find the speed reference voltage of your carriage drive is not really zero at standstill, you can use the offset registers for compensation.

8. Auxiliary Register and Command Codes

The following auxiliary registers are accessible by serial link, with the access codes shown (R = Read only, R/W = Read/write)

Code	Name	Function
:1	Error Count (R)	Shows the differential number of encoder increments between the scheduled carriage position and the real carriage position at any time
:2	LV value (R)	Represents the actual feed forward signal (speed profile) of the carriage drive. 0 = Standstill 4095 = maximum speed.
:3	Length counter (R)	32 bit counter counting continuously the length of the material passing the measuring wheel. Reset to zero by external Reset command.
:4	Carriage position (R)	position counter showing the actual carriage position with respect to "HOME".
:5	Integrator (R)	Current value of the integral part of the correction signal during synchron phase.
:7	Batch counter (R/W)	Increments with every cut executed. Decrements by input "Dec counter". Can be preset to zero or datum.
:8	Waste counter (R/W)	Increments with every "Immediate Cut" signal. Can be preset to zero or datum.
:9	Line Speed (R)	Represents the encoder frequency of the measuring wheel. 1 bit = 5Hz.
;0	Error Status (R)	Shows internal error state. 3 = Overflow print mark buffer (trip) 2 = Min. Position touched (trip) 1 = Cut not executable. Carriage to restart before back home (trip).
;2	Absolute Pos. (R)	Indicates the absolute position of the carriage, with respect to the "ZERO" position set by the Teach input.
;5	Min. Position Error (R)	Minimum position error of the carriage between the "ready to cut"- and the "cut complete"-signal.
;6	Max. Position Error (R)	Maximum position error of the carriage between the "ready to cut"- and the "cut complete"-signal.
<4	Actual Cutting Length (R)	Actual cutting length.
<5	Master Z-Distance (R)	Distance between two index pulses of the line encoder (in encoder increments, including multiple edge count).

Beside the serial access codes shown in this manual, the subsequent codes are available to execute the same commands that can be activated by the hardware inputs also:

Ser. Code	Bit of control word (C86)	Function	Type
55	14	Length select	S
56	4	Read PI data	D
57	2	Cut completed	S
58	0	Start / Stop	S
59	15	Immediate cut	D
60	7	Reset	S
61	13	Set zero position	S
62	12	Dec. batch counter	S
65	6	Jog forward	S
66	5	Jog backwards	S
67	3	Activate data	D
68	1	Store EEPROM	D

S = Static command, must be set to 1 to activate command and must be reset to 0 to deactivate command.
D = Dynamic command, must be set to 1 to activate command. Is automatically reset to 0 after execution.

All commands can be activated either by its serial access code or by setting the corresponding bit of the **control word (Ser. Access code 86)**.

Please note that all serial commands are logical ORed to hardware commands (control inputs) and hence a command is ON whenever set by serial command or hardware input or both at a time.

The state of the control outputs can be read out by the **status word (Ser. Access code 85)** via serial interface. Bit 7, 6, 5, ..., 1, 0 of the status word correspond to control outputs PI/PO pin 5, 17, 4, 16, 3, 15, 2, 14.

For more details please refer to the manual of the Drivecom protocol which is available on request.

9. How to operate the Keypad

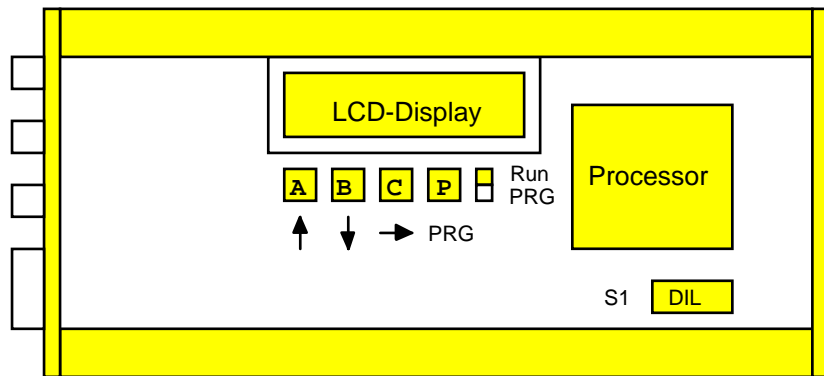

Fig. 32

To access the operator PCB, remove right hand side plate.

The on board setting controls comprise an LCD display, 4 small buttons and a sliding switch. When the switch is selected to "Run", the LCD permanently displays the software version of the program and the buttons A, B, C and P have no function.

Programming by the on board setting controls requires the sliding switch to be slid to "PRG". For external PC setting it must however be in the „Run“ position.

The buttons have the following control functions (Cursor highlights the register):

- Button A:** Scrolls register down; scrolls menu forward and also increments the highlighted digit.
- Button B:** Scrolls registers up; scrolls menu backward and also decrements the highlighted digit.
- Button C.** Returns from register to menu titles; increments highlighted digits to the right, (or from full right to full left).
- Button P:** Enters from menu to registers; changes register from text to value and back to text again. Stores actual data to the EEprom.

The following example shows how to set the "Acceleration 1" register of the Data In menu (see register table).

Action	LCD
• Slide the switch to "PRG"	<div style="border: 2px solid yellow; border-radius: 10px; padding: 5px; width: fit-content; margin: 0 auto;">Data IN</div>
• Select the Data IN Menu by pressing "P"	<div style="border: 2px solid yellow; border-radius: 10px; padding: 5px; width: fit-content; margin: 0 auto;">Imp Line</div>
• Press "A" several times until the LCD shows "Accel 1"	<div style="border: 2px solid yellow; border-radius: 10px; padding: 5px; width: fit-content; margin: 0 auto;">Accel 1</div>
• Select the Accel 1 register by P and read the actual setting (i.e.1000)	<div style="border: 2px solid yellow; border-radius: 10px; padding: 5px; width: fit-content; margin: 0 auto;">1 0 0 0</div>

- **Change setting to i.e. 500 msec like shown:**

- Key B decrements digit highlighted by cursor

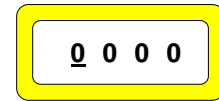

- Key C shifts cursor right

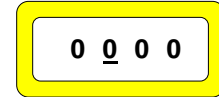

- Key A increments highlighted digit. Press A 5 times.

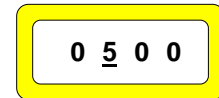

- Press P to store the new value



When you slide the switch back to "RUN", you read again "FS15013" and the unit is ready to operate.

When you press "C" instead, you come back to "DATA IN" etc.

Please note:

The unit is unable to operate or to make serial communication while the slide switch is in the "PRG" position!

10. The LED Display

The 8 LED's mounted on front of the module indicate the instantaneous positional error between the real carriage position and the position where it should be in respect to the line. The display provides information for commissioning and fault monitoring, in a very simple form.

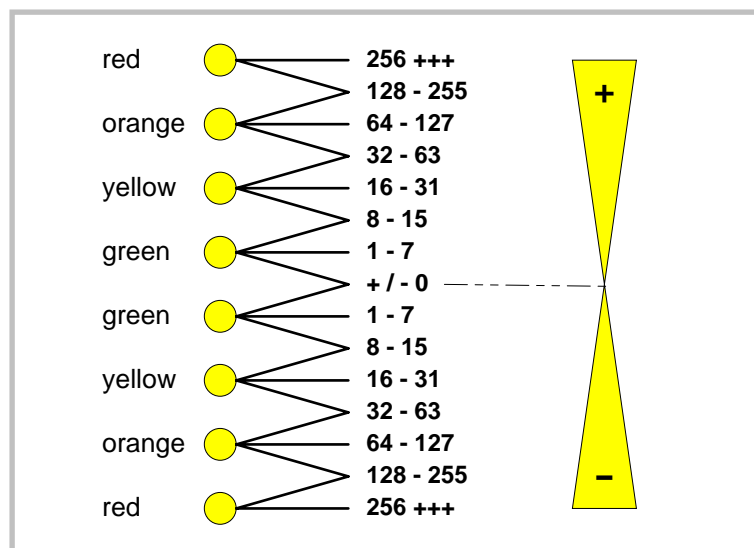

Fig. 33

When both green LED's in the center are lit, the positional error is absolutely zero, this means the carriage is exactly where it should be at that time.

When either of the green LED's is lit alone, the error lies between 1 to 7 encoder bits. When one green and one yellow LED is lit, the position error lies between 8 to 15 bits, etc.

When the lights are up, this indicates positive correction (Line leads carriage)
 When the lights are down, this indicates negative correction (Line lags carriage)

The above notes hold for positive reference and forward motion. Everything is reversed for negative reference and reverse motion.

Under regular production conditions, with the unit properly set up, you should find the LED's in their center range at any time with the green and perhaps one yellow LED blinking..

11. Steps for commissioning

In principle, all commissioning could happen without a PC, just by use of LCD and keypad. Since, however, things go much easier and faster, we recommend you to use the OS30 operator software and follow the subsequent steps.

11.01 At this time you must be sure your carriage drive is adjusted for proper operation and maximum dynamics. Remove any ramps and delays from the drive because the FS150 controller will produce the ramps. Make sure the drive can run the maximum speed with a speed reference of 9 Volts already (We must leave 1 Volt of output swing for the FS150 to make corrections). For the setup procedure it is best to mechanically disconnect the motor shaft from the carriage, so we can run the motor continuously and need not to observe the mechanical limitations of the carriage.

11.02 Make sure all connections are correct and DIL switch S1 is set according to need.

You must be sure your carriage drive runs forward (direction of the line) when it receives a positive voltage. If not, you must change this on your drive now.

11.03 Power the unit up, connect the serial cable to the PC and start the OS30 software.

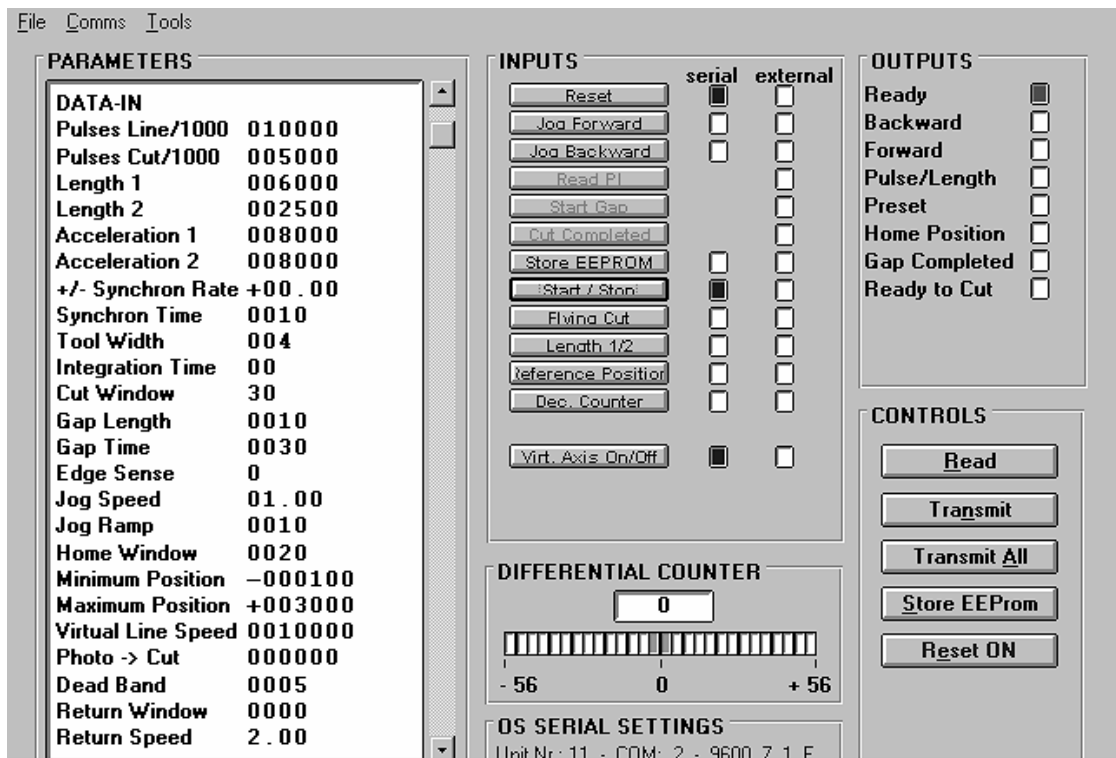

11.04 Set all registers according to need.

For Virtual line speed select a small value (e.g. 10m/min) for the first steps. Also it is better to start with lower acceleration values and to optimise them later.

The following registers must be set to initial values like shown:

+/- Sync	: 00.00	Mode	: 1
Int Time	: 00	Add Cor	: 1
Cut Wind	: 99	Gain Cor	: 200
Return Speed	: 1.00	Gain Tot	: see table
		Unit NR.	: 11
		Baud Rate	: 0
		Ser Form	: 0

Fig.34

The initial Gain Tot setting depends on the expected maximum frequency of the line encoder (frequency in KHz at maximum line speed)

f max	Gain-Tot
1 KHz	170 000
3 KHz	57 000
10 KHz	17 000
30 KHz	5 700
100 KHz	1 700

For frequencies between use interpolated values. Initial setting can be approximately.

Fig.35

Setting of registers "Mast-Dir" and "Slave-Dir" is not important at this time.

Click "Transmit All" and then to "Store EEprom" to store your settings to the FS150 controller.

11.05 We must first set the counting direction of the encoders. Select the “**Test**” function in the **Tools**” menu.

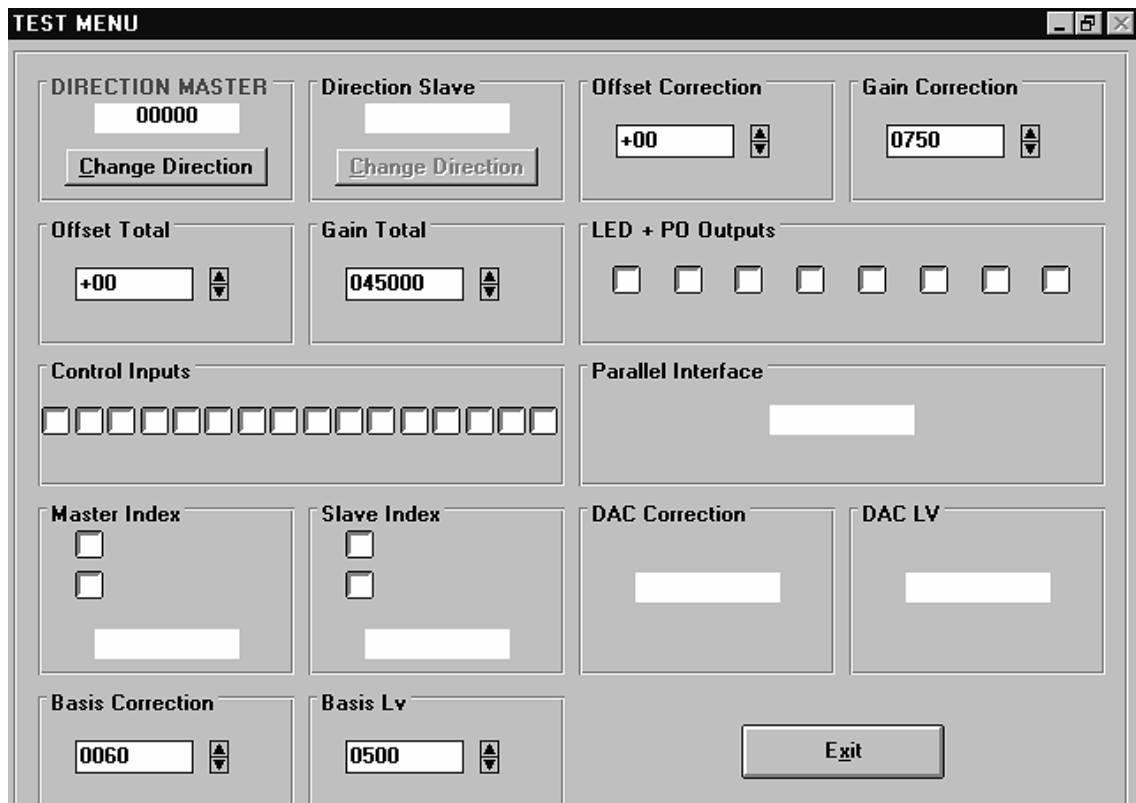

Click to the “**Master Direction**” field. Rotate the Master encoder in forward direction, e.g. the direction it will rotate later with the material. The counter in the Master Direction field must **count up**. Where you find we count down, click “Change direction”.

When we count up, click to the “**Direction Slave**” field. Enable the carriage drive now. It will rotate with the speed set to the “virtual line” register. Also this counter must **count up**. Where you find we count down, click “change direction”. When we count up, click to any other field to stop the carriage drive again.

11.06 Where you use the parallel interface for length preset (e.g. with a remote BCD switch or a PLC data output), please click to the “**Parallel Interface**” field and verify the parallel data arrive correctly.

11.07 Click “Exit” now to return to the normal screen. This will save the settings in the controller. At this time you should check if the **control inputs** you use operate correctly. Apply all signals like “Reset” or “Start/Stop” and see if the signal change is visible in the “external” column of the Inputs field of your screen.

11.08 As a next step, we must set the **Gain Total** value for the analogue feed forward signal. Make sure the carriage drive is enabled to run, then select the “**Adjust**” function in the “**Tools**” menu. The carriage drive will immediately start to run with the speed set to the virtual line register.

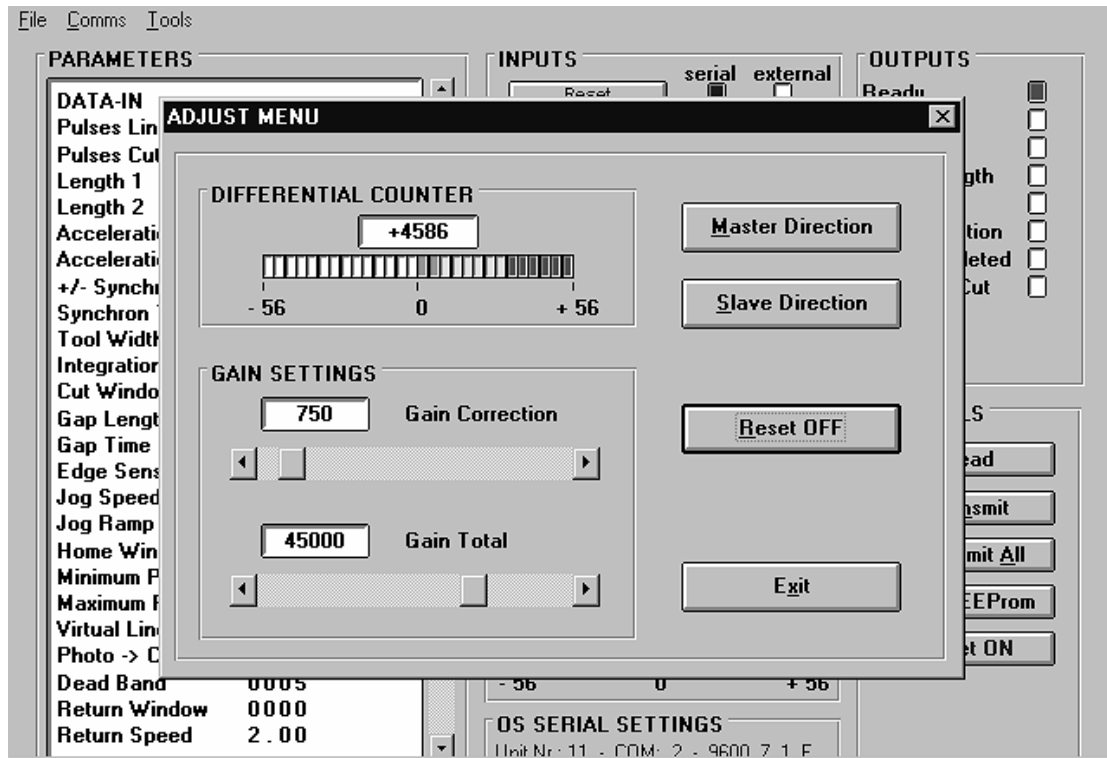

We must observe the colour bar graph and the differential counter now while we adjust the “Gain Total”. Gain Correction should always be set to 200 during this procedure.

When we click the Reset to “ON”, our differential counter will show zero and the bar graph will be in it’s green center position.

When we click the Reset to “OFF”, our differential counter will run away and the bar graph will move to one or the other direction.

We must find now a setting for Gain Total that keeps our counter close around zero (i. e. -5....0....+5) and the bar graph in its green/yellow center position.

- When the counter counts to positive (bar graph moves to right):
Gain Total is too low and must be increased.
- When the counter counts to negative (bar graph moves to left):
Gain Total is too high and must be reduced.
- For important changes of Gain Total use the slide button in the Gain Total field.
For fine tuning, use the ► and ◀ buttons.

11.09 When Gain-Total has been set correctly, we must now adjust **Gain-Correction**.

The rule is to have Gain Correction **as high as possible**. Typical values are from 300 to 1000, sometimes even 2000. Where you find your drive starts oscillating or running roughly, reduce Gain Correction again until we have stable operation. To change Gain-Correction, use the slide button or the ◀ and ► keys.

11.10 We now can exit the Adjust Menu and return to the main menu. The machine is ready to cut and we can simulate automatic cutting cycles.

Hint:

When you cannot get the “Cut completed” signal because the carriage drive is mechanically disconnected to the machine, it is legal to link directly the “Ready to cut” output to “Cut complete input”. This is valid for testing purpose only!

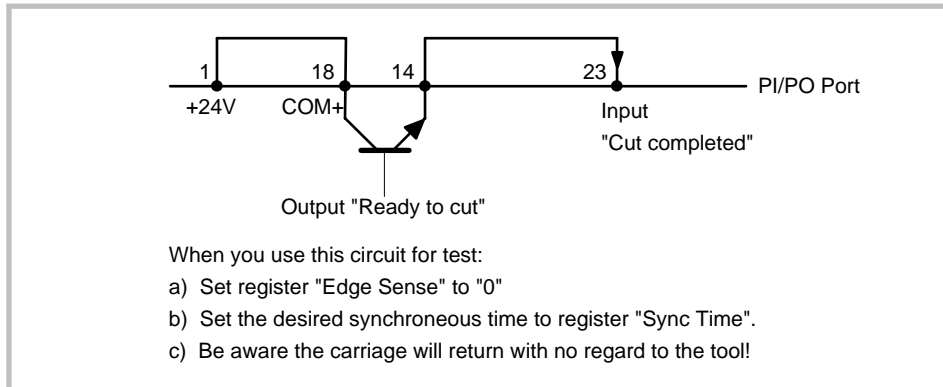

Fig.36

- Put the carriage to the desired Home position by using the Jog function. Where your software limit switches would not allow you to reach the desired position, keep the "Set zero position" input High while you jog.
- Make sure your software limit switches (Min-Position, Max-Position, Alarm Preset) are correctly set so the carriage can move over the desired range. The software limit switches will not work while the „Position Reset“ is High, because this keeps the carriage position counter to zero.
- Set a long length and a low virtual line speed for the first tests.
- Have the Start/Stop input at stop while you switch the virtual line input to high.
- Set the start signal to "High".
The virtual line is running now and the carriage is waiting for the first cut. On the screen you can see the Pulse/Length output blinking. This indicates the virtual line is running
- Watch the colour bar on the screen (or even better the LCD's on the front of the unit) while we cut. We should stay in the green/yellow center field all the time. Increase the virtual line speed step by step while you continue watching the front LED's. Please do not use big steps. Increase like 10....20....30....40....50m/min, but never from 10 to 50 directly because this can cause problems.
- Where, during forward acceleration, the LED's move up, our "acceleration1" setting is too high and must be reduced (drive cannot follow the ramp).

Where, during reverse acceleration, the LED's move down, our "acceleration2" setting is too high and must be reduced (drive cannot follow the ramp).

Where during accelerations the LED's remain stable, you can increase the acceleration settings in order to get steeper ramps and faster cutting cycles.

You can also use the oscilloscope function of the operator software. Set channel one to serial code **:1** to show the synchronising error.

Set channel two to serial code **:2** to show the carriage speed profile (The speeds appear positive in both directions)

The subsequent picture shows a typical example where the “acceleration2” setting is too high and the drive cannot follow the ramps. This is indicated by synchronising errors while the carriage accelerates or decelerates in reverse direction.

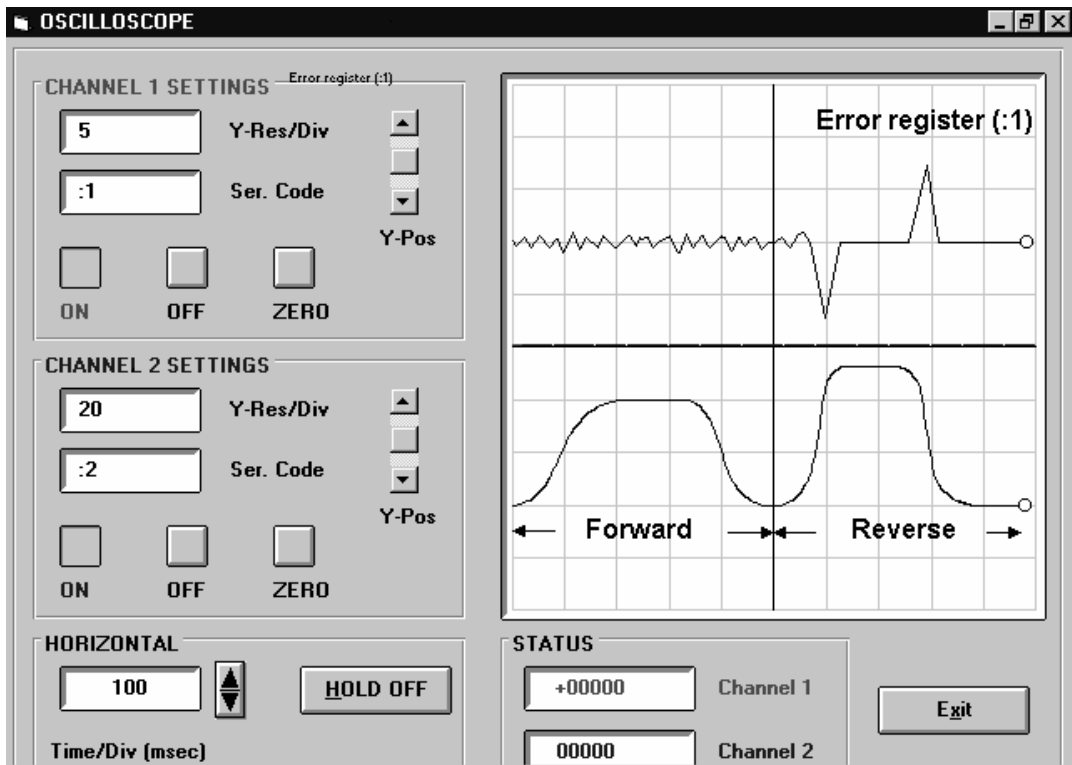

11.11 We can try now to optimise some other settings:

- reduce the “Cut Window” setting to e.g. 20 and set „Integration Time“ to e.g. 30 at the same time. These are typical setting for most applications.
- Increase the “Return Speed” ratio in order save time. The carriage will than return with higher speed.
- Increase acceleration settings to the limit where the drive still follows, whenever you need highest production efficiency.
- Keep the cutting time of the saw blade or shear as short as possible to reduce cycle time.

This concludes the setup procedure of the FS150 Flying Shear Control. We recommend you to store your settings on a disc or the harddisc of your PC. In case of exchange of the unit you just need to load down the parameter file to the controller to be ready for production again.

12. Alarm States and Conditions

We recommend to use the “Ready“ output for alarm and **trip control**. When the unit trips to Alarm state,

- the Ready signal will go low
- the analogue output will go zero
- no further control will be maintained
- the two green center LED's on the front will blink
- serial communication will be possible and the reason for the trip can be read out from register **;0**.

To **exit** the Alarm State:

- Apply a High signal to the Reset input or
- Push the small Reset button located behind the front plate or
- Power down and up the unit again.

Please be aware the unit will immediately trip again unless the reason for the alarm has been removed.

These are possible **reason** for the unit to trip:

- During automatic production, the carriage touches the rear software limit switch (Min. Position)
- A cut cannot be executed because the carriage has not returned Home before it should restart again (cutting length too short or line speed too high)
- In mode 2 (Print Mark Operation), more than 10 marks have been detected between the photocell and the Carriage Home Position (stack overflow).

There is one alarm situation that needs to be controlled by remote customer circuit individually according to demand:

In automatic operation, the FS150 provides a High signal at the **carriage alarm output** when, during forward motion, the carriage position exceeds the preset level. The unit however will not stop the drive nor trip, but just signal that the preset position has been exceeded.

13. Accuracy considerations

It is easy to understand that the FS150 controller functions are based on correct information from the encoders. When you observe the LED at the moment when a cut takes place, you can easily see what the theoretical cutting error can be. In practical applications, with the drive and the unit properly adjusted, the cutting error should be limited to 4-7 encoder increments and the resolution of the encoders will give the real error expressed in length units.

Where you find the real errors are more than indicated by the LED, you must check for the following items:

13.01 Slip of the feed roll or the measuring wheel.

13.2 Measuring wheel not exactly orthogonal to the material line or not exactly round, or tolerance in diameter.

13.03 Length change of the material between the measuring wheel and the position where the cut takes place (i.e. shrinking of hot material that cools down or stretching due to mechanical deformation prior to cut).

13.04 Clearance or backlash of the carriage drive or the cutting tool etc.

13.05 Noise on the line encoder signal or the carriage encoder signal.

Noise on the encoder signals can cause cutting errors as well. Noise on the carriage encoder signal can easily be detected because it causes the home position of the carriage to shift. Noise on the line encoder signal can be detected by reading the register “<5” (see “8. Auxiliary register and command codes”). This register must always contain the number of pulses of the line encoder (including multiple edge count). If the contents of this register varies by more than +/- 1 encoder increment there is noise on the line encoder signal that involves cutting errors. Using this function requires the Z and Z' outputs of the line encoder to be connected to the FS150 controller.

13.06 Incorrect synchron ratio

An incorrect synchron ratio (values of parameters “Pulses Line/1000” or “Pulses Cut/1000” incorrect) can cause considerable cutting errors that are particularly big when the line speed changes. To check your synchron ratio proceed as follows: First check the parameter “Pulses Cut/1000” (either by calculating it from your theoretical machine data or – if you are not 100% sure that the theoretical data are correct - by measuring it). To measure this parameter you can use the carriage position counter “:4” that counts the carriage encoder pulses. Next move the line forward until there is material under the shear, stop the line and perform a flying cut. Then switch the Start/Stop-Input to high and start the line. Measure the first piece of material that has been cut after the line has been started and compare its length with the length preset of the FS150 controller. If the measured length is shorter than the length preset the value of parameter “Pulses Line/1000” is too low and must be increased. If the measured length is longer than the length preset the value of parameter “Pulses Line/1000” is too high and must be decreased. Repeat this procedure until you have found the correct setting of “Pulses Line/1000” (measured length and length preset are equal).

If all of the above points have been checked and eliminated the remaining cutting errors can basically consist of two components: The electronic cutting error caused by the FS150 (which can be seen on the LED display) and the error caused by the length measurement (slip of the measuring wheel etc.). There is a fundamental difference between these two errors: The electronic error is independent of the cutting length whereas the length measurement error generally is proportional to the cutting length. Hence the two errors can be separated by a linear correlation function.

Example: Measuring 100 pieces of L = 0.5m, 1m and 2m at the same line speed has shown the following cutting errors:

$$L = 0.5\text{m} \rightarrow \Delta L = \pm 0.4\text{mm}, \quad L = 1.0\text{m} \rightarrow \Delta L = \pm 0.5\text{mm}, \quad L = 2.0\text{m} \rightarrow \Delta L = \pm 0.7\text{mm}$$

Hence, we have the following equation for ΔL : $|\Delta L| = 0.3\text{mm} + 0.2 \frac{\text{mm}}{\text{m}} \times L$.

Consequently the electronic cutting error (that is independent of the length) is $\pm 0.3\text{mm}$ and the length measurement error (that is proportional to the length) is $\pm 0.2\text{mm/m}$.

It must be pointed out that the front LED's are a reliable means to judge the cutting error. A rough estimation of the electronic cutting error can be obtained by reading the registers “;5” and “;6” that store the minimum and the maximum of the carriage position error from the “ready to cut”- to the “cut complete”-signal (unit: carriage encoder pulses; must be converted to length units by using parameter “Pulses Cut/1000”).

When the line and/or the carriage do not move smoothly, you could find 4 or even more LED's ON at the time where we cut takes place. This however, in general, does not mean higher cutting errors. The LED's are updated with a 100 μ sec scan and display any kind of vibration, whilst the drive operates in a millisecond range and performs the average of what the LED's say.

14. Which shortest length can we cut at a certain line speed?

Flying shears have physical limitations in respect to short cutting length at high line speeds and not every length can be cut at any line speed. This should be shown by the following example:

When we would need to cut pieces of 1 meter length at a line speed of 60 meters/minute, this means we must execute one cut every second. If our saw blade would take one full second to perform the cut, it is easy to understand that this cannot work (There is no time left to accelerate, decelerate and return to home position).

The following formulae allow calculation of the shortest cutting length possible at a certain line speed:

L min	: Shortest possible length [meters]
R1	: Rampe 1 time for forward motion[seconds]
R2	: Ramp 2 time for reverse motion [seconds]
T	: Duration of the cut itself [seconds] (Time between termination of the acceleration ramp and the external "Cut completed" signal)
V L	: Actual line speed [meters per <u>second</u>]
V R	: Maximum carriage return speed [meters per <u>second</u>]

Fig.37

Please note formulae use **ramp times** and not acceleration values, because otherwise we would get equations of third order which you would be certainly unable to solve.

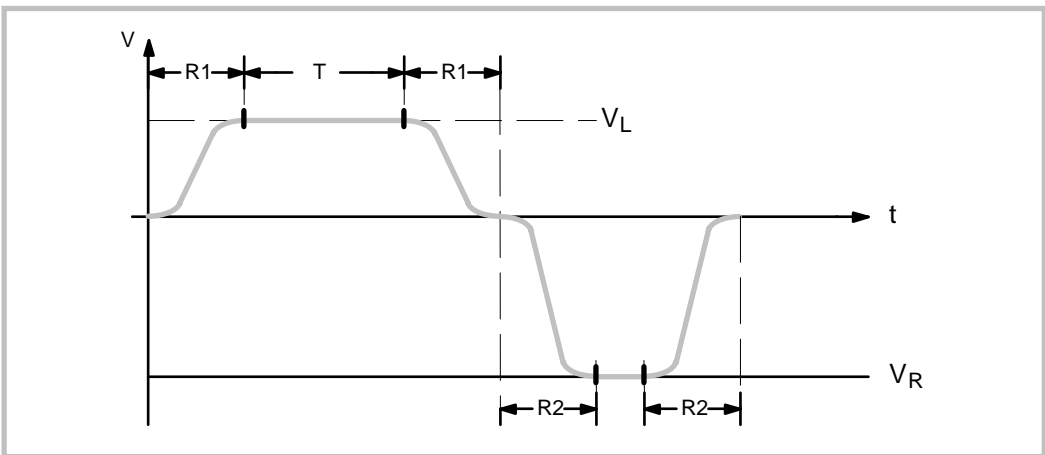

Fig.38

We need to separate two cases:

a) When $(R_1 + T) \cdot V_L \geq R_2 \cdot V_R$:

$$L_{\min} = V_L \cdot \left[R_1 \cdot \left(2 + \frac{V_L}{V_R} \right) + R_2 + T \cdot \left(1 + \frac{V_L}{V_R} \right) \right]$$

b) When $(R_1 + T) \cdot V_L < R_2 \cdot V_R$:

$$L_{\min} = V_L \cdot [2 \cdot (R_1 + R_2) + T]$$

Where you must cut shorter length, you must reduce line speed.

15. Which maximum line speed can we use with a certain cutting length

We need to separate two length ranges to calculate the maximum line speed.

a) When $L \leq V_R \cdot \frac{R_2}{R_1 + T} \cdot (2R_1 + 2R_2 + T)$

our maximum line speed must not exceed

$$V_{L_{\max}} = \frac{L}{2R_1 + 2R_2 + T}$$

b) When $L > V_R \cdot \frac{R_2}{R_1 + T} \cdot (2R_1 + 2R_2 + T)$,

our maximum line speed can be

$$V_{L_{\max}} = V_R \left(\frac{-2R_1 - R_2 - T + \sqrt{(2R_1 + R_2 + T)^2 + \frac{4L}{V_R} \cdot (R_1 + T)}}{2R_1 + 2R_2 + T} \right)$$

16. Which travelling distance does our carriage need?

This question may be important for the mechanical construction of our carriage system.

$$d = V_{L_{\max}} \cdot (R_1 + T)$$

17. General Master Reset and Erase of EEPROM

The unit carefully checks all entry data for validity and correctness within their permitted numeric range. If, as an extreme exception, invalid data should intrude into the register range, bad function or even a full hang-up could be the result. If this should ever happen

- push the Reset button on the unit`s front (accessible by a small screw driver only)

or

- power down the unit and power up again after a few seconds.
Both measures result in a complete reconfiguration of all ports and registers. **RAM and buffer data will be lost** and the unit restores all data from the EEPROM.

If, however, invalid data should have penetrated to the EEPROM, even the previous steps will not help. In this case we must erase the EEPROM:

- switch off the unit
- set the slide switch PRG/RUN to the PRG position
- keep key A down while powering up the unit and keep it down for at least another 5 sec.

This will clear up all the EEPROM to it`s minimum values, and all registers need to be setup once more.

Above steps represent an emergency procedure that you will never have to apply under regular conditions. In an extreme case however (i. e. lightning-strike in the factory etc.) they could help to get the unit working again.

It is mandatory erase the EEPROM when the processor has been changed for reasons of software upgrade.

18. The BY 106-X Remote Thumbwheel Switch

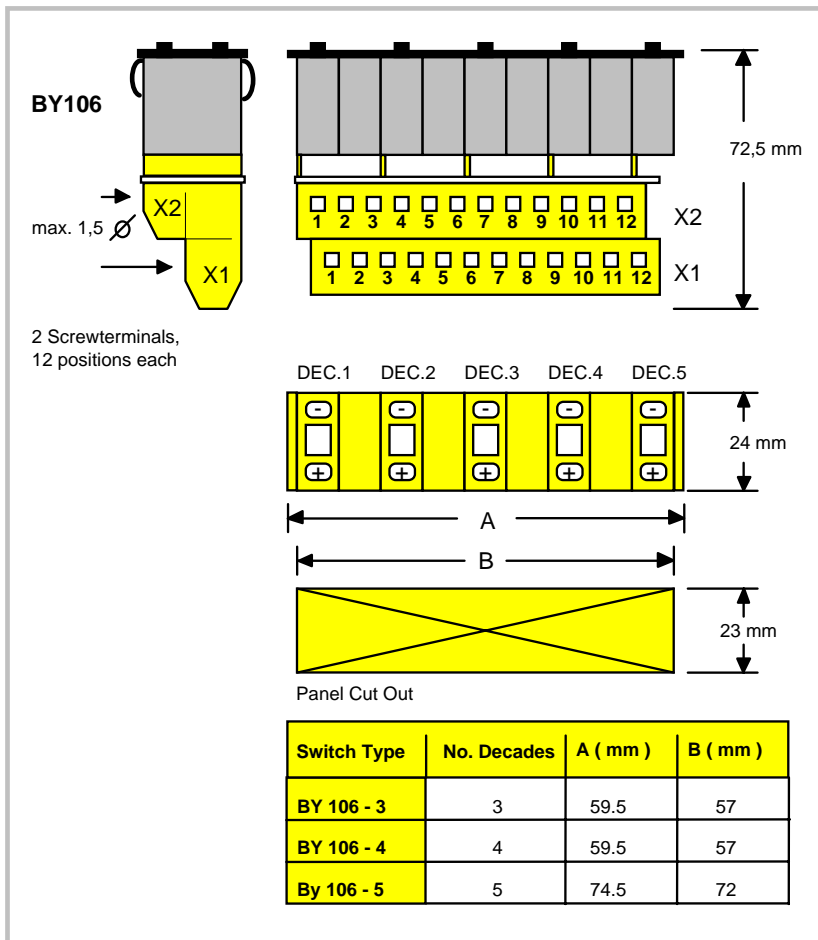

Fig.39

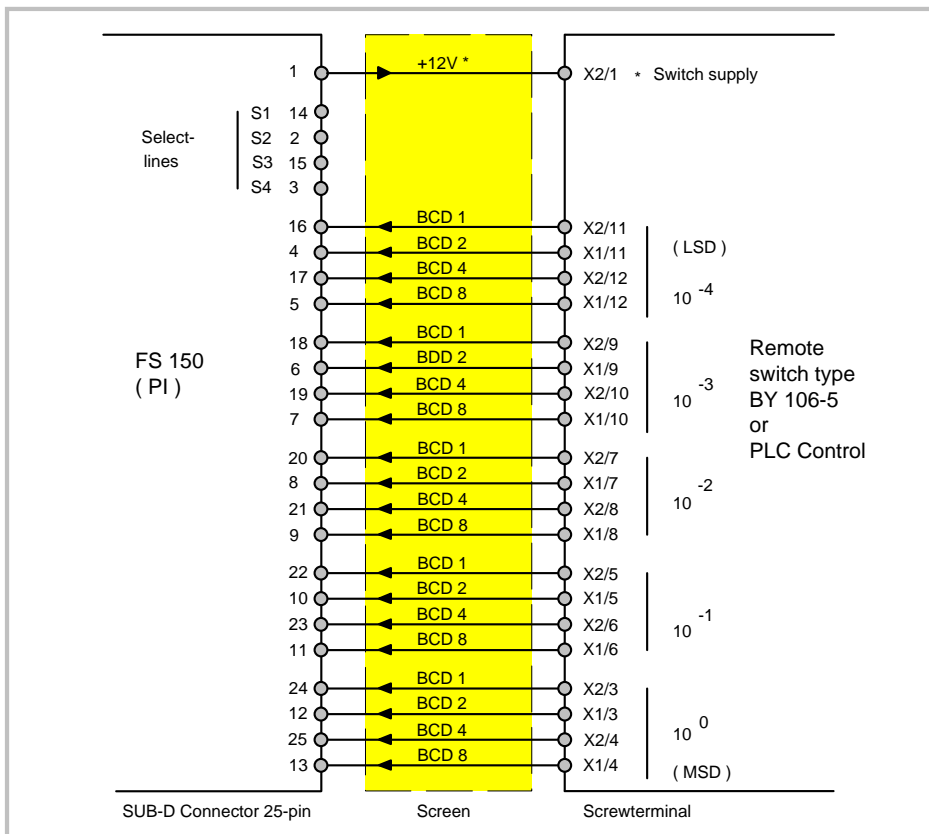

Fig.40

19. Dimensions and Specifications

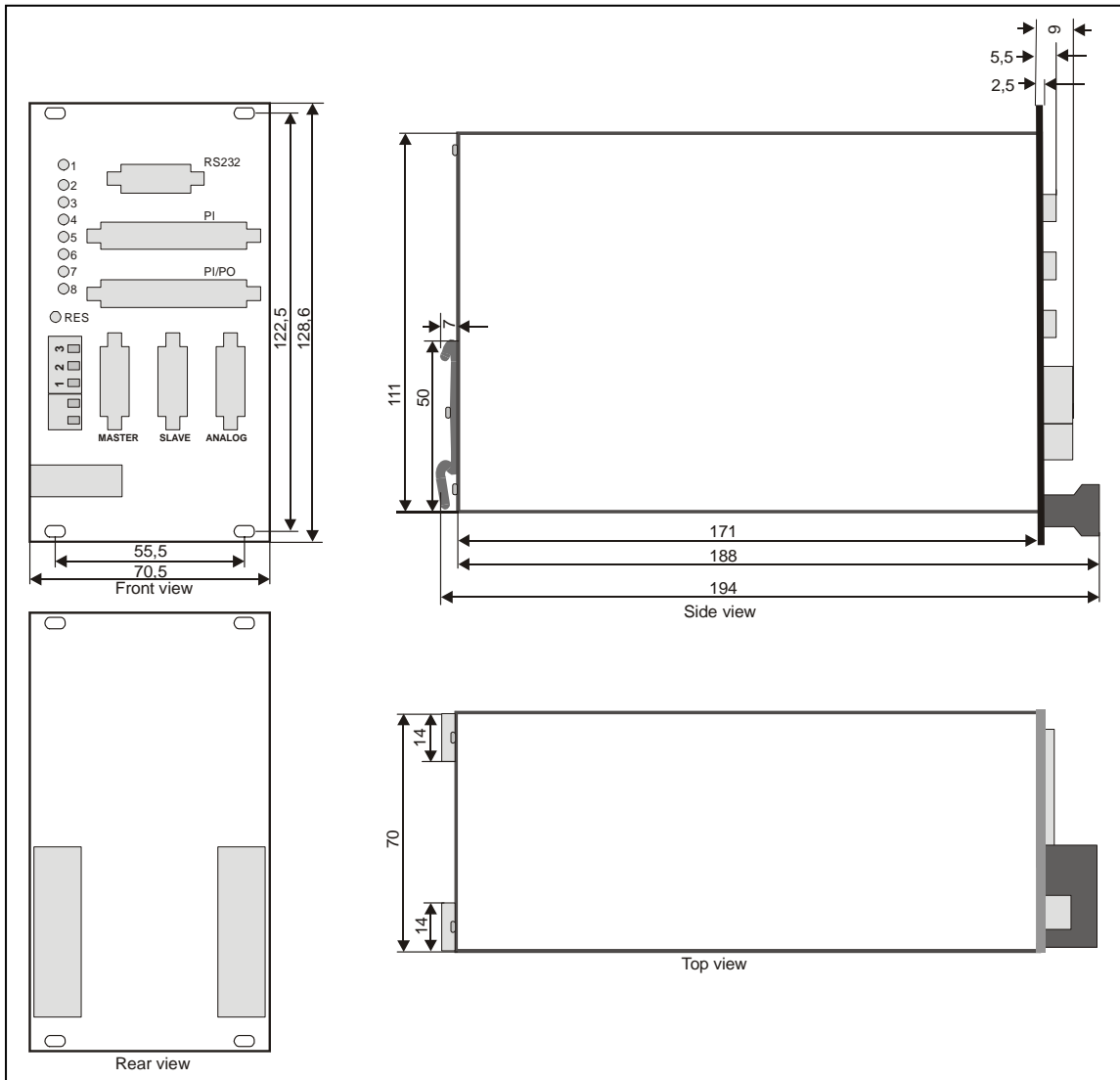

Fig.41

Power supply	: 18...30 V unstabilised
Consumption	: approx. 300 mA (plus 25% of the encoder supply currents, if internal encoder supply used)
Encoder Supply	: Aux. voltage 5,5 V, max. 500 mA installed
Processor	: H8/532 with 20 MHz clock frequency
PCB and Technology	: SMD, Multiplayer PCB`s, High speed logic 74 HCT
Encoder Inputs	: Two A, A', B, B', Z, Z' (5 V TTL opto-isolated) Low < 0.8 V, High > 3.0 V (4.0 V with differential input signals)
Other Inputs	: 1 parallel port PI (24 lines) 1 control port (12 lines) all PNP with 18 - 30 V level.
Serial link	: RS 232 with DTR output (RS 485 optional)
Absolute max. frequency	: 325 kHz
Response time	: approx. 150 µsec
Analogue Output	: +/- 10 Volts (5mA max.) Resolution: 12 Bit (= 4096 steps)
Analogue Correction Saturation	: 10 Bit = 1024 error increments
Error memory	: 32 000 error increments
Control Outputs	: 8 transistor outputs (opto-coupler 30V/50 mA max)
Speed error	: +/- 0,00 (absolute)
Cutting accuracy	: Typical +/- 5 encoder increments
Operating temperature	: 0...45 °C
Dimensions	: see drawing
Weight	: Approx. 850 g

20. History

Version	Name	Date:	Page:	Changes / Supplements:
FS15016N	TJ	Oct. 03	21 26 42	Max. 8 print marks between sensor and home position Control word and status word Encoder inputs levels and max. frequency