



BY 150

High Performance Synchrocontrol Operating Instructions and Operator Software OS 3.2



- 300 kHz counting frequency
- Highly dynamic response (100 μ sec)
- Positional synchronisation and ratio control
- Marker pulse and print mark registration
- Full quadrature encoders counting x1, x2, x4
- TTL encoder inputs (A, \bar{A} , B, \bar{B} , Z, \bar{Z})
- Easy LCD display setting or PC setting via serial link. Data loading on the fly
- Remote control facilities via parallel interface, serial RS232/ RS485 link or via CANopen network
- EEPROM and RAM memory
- Simple to mount and setup (rack or DIN rail)

Table of Contents

1.	Introduction	Page	3
2.	Principle of Operation	Page	3
3.	Impulse Scaling	Page	5
4.	Ratio Change During Operation	Page	7
5.	Change of Phase and Relative Position	Page	8
6.	Index Registration and Control	Page	8
7.	Wiring and Screening	Page	9
	7.1 Encoders	Page	12
	7.2 Analogue Connections	Page	14
	7.3 Power Supply	Page	15
	7.4 Parallel Interface	Page	15
	7.5 Control Inputs and Outputs	Page	17
8.	The Serial Port	Page	19
9.	How to operate the Keypad (not needed with PC setup)	Page	20
10.	Modes of Operation	Page	23
11.	Data Menu	Page	24
12.	Setup Menu	Page	26
13.	Adjust Menu	Page	29
14.	Testprg - Menu	Page	29
15.	The LED Display	Page	30
16.	Analogue Signal Guide	Page	30
17.	Digital Signal Guide	Page	31
18.	Remarks about Drives, Encoders, Cables Installation	Page	31
19.	Steps for Commissioning when using a PC and the OS3.x Software	Page	32
20.	Hints for Final Operation	Page	37
21.	Serial Codes	Page	39
22.	General Master Reset and Erase of EEPROM	Page	39
23.	The BY 106-X Remote Thumbwheel Switch	Page	40
24.	Dimensions and Specifications	Page	41
25.	History	Page	42

These instructions have been written and checked to the best of our knowledge and belief.

However, motrona will not be liable for errors and reserves the right for changes at any time without notice.

1. Introduction

The BY 150 synchronisers have been designed to tackle the high performance synchronisation and registration applications between two independent drives, where the speed and accuracy characteristics of other synchronisers are exceeded. The units are suitable for any kind of drives (AC, DC, Servo etc.), that are variable in speed under control of a 0-10 volts speed reference. The 300 kHz counting frequency allows use of high-resolution encoders even with high operation speeds. Due to the extremely short response time of 100 μ sec only, the unit also provides a proper synchronisation under highly dynamic conditions with servo drives.

As a matter of course, full ratio control and other functions like index pulse tracking, print mark registration, remote phase control and reversal facilities are included in the wide set of standard functions.

All settings are fully digital and no potentiometer adjustments are necessary. Programming of parameters is accomplished by a small keypad with LCD display, or by PC/Laptop, using our **operator software OS 3.0** (included on disc). The most important parameters are also accessible via parallel interface and can easily be changed "on the fly", with use of a remote thumbwheel switch or a PLC control. All variables are accessible by serial RS232/RS485 communication. CAN interface is available as an option, providing full communication facilities in a CANopen network.

For special applications like control of Rotating Cutters, Flying shears or Positioning Systems, the same hardware can operate with software versions specially designed for these applications. Information is available on request.

The mechanical construction uses a closed 19" aluminium cassette with all connections on its front. Rack mounting of the cassette therefore does not require use of a swivel frame. Use of our **SM 150 back plane** (option) also allows easy DIN rail mounting.

The BY 150 operates from an unregulated 24 VDC supply (18 V... 30V) via front power connector (included with delivery) and is fully in line with other series 150 models, thus accomplishing the range of various useful modules for solutions with drive applications.

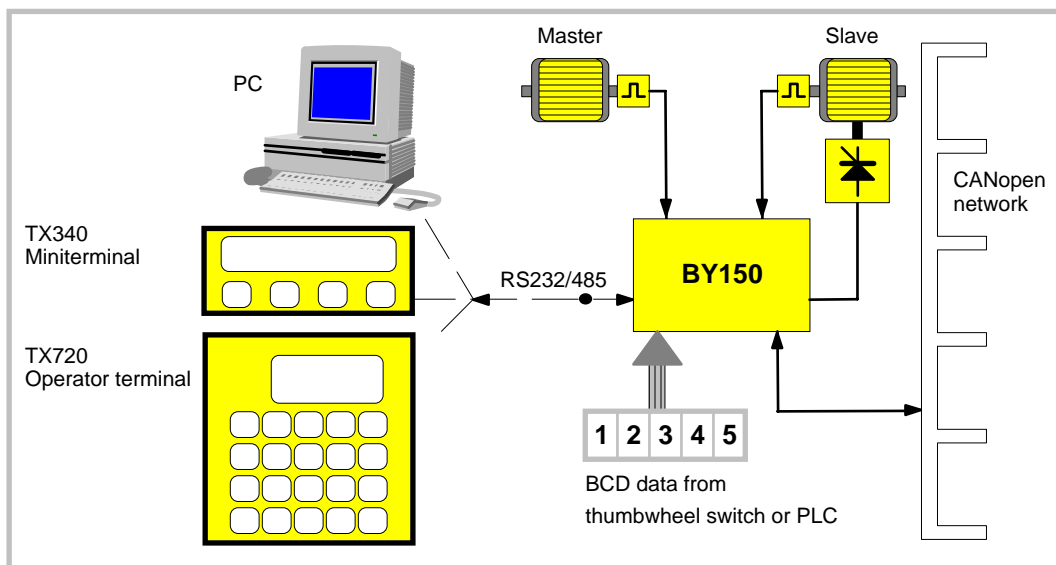

Fig 1

2. Principle of operation

All operation is based on setting an "analogue synchronisation" between the drives first. This can be achieved by feeding a common speed reference voltage to the drives and tuning the drive speeds in order to get them into an approximate synchronism. A ratio adaptation may be necessary for the Slave drive, as shown in figure 1. This analogue pre-synchronisation can match the two speeds within an error range of a few percent.

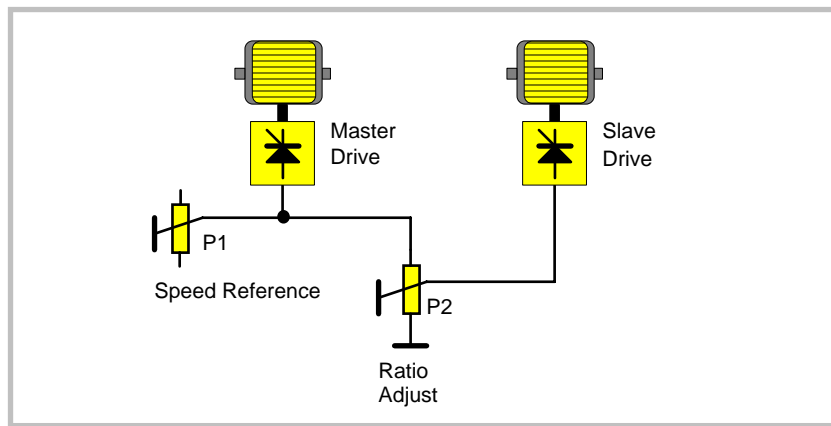

Fig. 2

The digital synchronisation now has to compensate for the analogue speed errors in order to get an **absolute, angular** and **positional** synchronisation with **no drift** and no cumulative displacement of the motor shafts. This needs a digital feedback of the angular shaft position of the drives. In general, incremental shaft encoders or equivalent signals. (i. e. encoder simulation from a resolver system) are used.

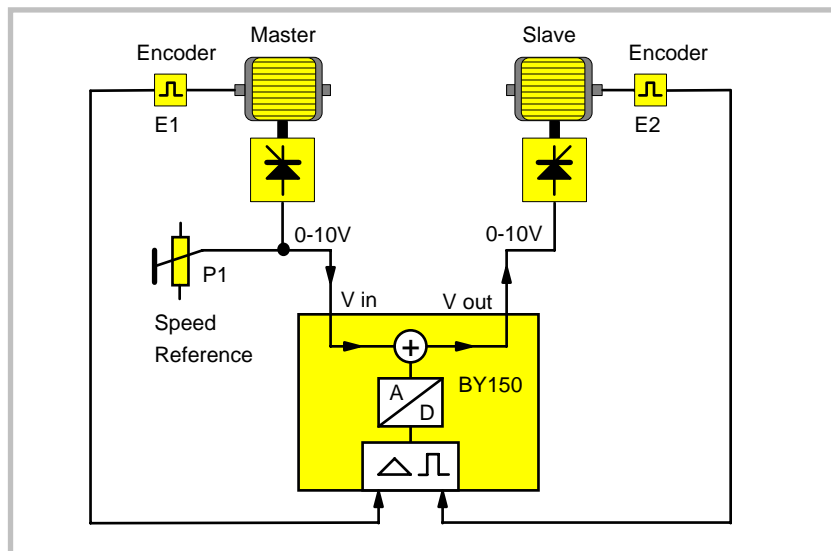

Fig. 3

The synchroniser continuously checks the two shaft positions and immediately responds by an analogue correction signal when an angular error starts to appear. This analogue correction, added to the slave's reference with the correct polarity, will keep the shaft positions of Master and Slave in line. As the synchroniser responds within only microseconds to each individual encoder pulse, the slave will practically have no chance to drift away.

Fig. 3 shows that a **feed forward signal "Vin"** is needed to run the drives, and a correction voltage is added to receive the total slave speed reference "Vout". It is easy to understand that the feed forward signal must be proportional to the master speed. There are two ways to generate Vin:

- a) Use of the master speed reference voltage, like shown in Fig. 3. This presumes the master drive does not use any remarkable internal ramps, because otherwise Vin would not represent the real master speed upon acceleration or deceleration. As a result, procedure a) must only be used when the master speed reference already includes the ramp (generated by a PLC output etc.) and the drive's internal ramp is set to zero or it's minimum value. However, a real speed analogue signal from a tacho generator can be used at any time.

Analogue feed forward should only be used when replacing older existing BY150 units against a new one.

- b) Use of the ultra high speed frequency- to- voltage converter installed in the BY150 units.
This procedure can be used for most of all applications.

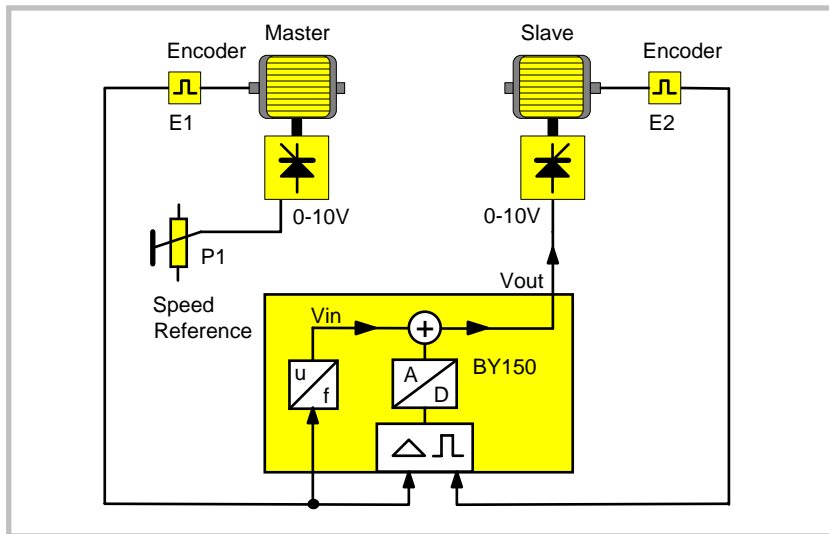

Fig. 4

The feed forward signal now is generated internally from the frequency of the master encoder and no external voltage must be applied to the analogue input. This allows the master drive to use internal ramps, because the encoder frequency always represents the real actual speed of the master.

Also, procedure b) allows the "Master" to be just a measuring wheel with encoder, instead of really a drive.

3. Impulse Scaling

For easy adaption of the synchroniser to operational and physical conditions (gear ratios, encoder resolution, roll diameters etc.), both, Master and Slave impulses can be scaled separately. The scaling factor "**Factor 1**" provides impulse scaling for the Master channel and the scaling factor "**Factor 2**" does the same for the slave.

Both factors are 5 decade and operate in a range from 0.0001 to 9.9999. Setting them both to 1.0000 will result in a 1:1 speed and phase synchronisation. The factors can be set remotely via parallel interface, using a simple BCD thumbwheel switch or a PLC parallel output. Of course, remote setting is also possible from a PC with RS232/RS485 communication or with a CANopen network.

Independent of the way of factor setting, the slave always changes it's shaft position with respect to the master according to the following formula:

$$S_{\text{Slave}} = \frac{\text{Factor 1}}{\text{Factor 2}} \cdot S_{\text{Master}}$$

(Proportional operation)

$$S_{\text{Slave}} = \frac{1}{\text{Factor 1}} \cdot \frac{1}{\text{Factor 2}} \cdot S_{\text{Master}}$$

(Reciprocal operation)

Proportional or **reciprocal** operation can be selected by the parameter "**LV-Calc**" in the Setup menu.

Remarks to previous formulae:

When **positional** and **angular synchronisation** is required, we recommend to set S_{master} and S_{slave} to a number of encoder pulses received from the encoders when both drives move a defined synchronous distance or one defined machine cycle forward. When only **speed synchronisation** is needed (i.e. speed errors in a range of 10^{-5} can be accepted), S_{master} and S_{slave} can also be set to the encoder frequencies at synchronous speed.

For a normal, proportional operation, under consideration of all geometrical machine data, one would try to fix up the value of Factor 2 in a way to have Factor 1 directly in "User units". (Factor1 is the parameter that could be changed during production, and Factor2 is a "machine constant" that normally will never be changed).

The following example should explain the calculations for Factor 1 and Factor 2 with a feed roll system, where the tension of the material should be varied remotely by adapting the slave speed:

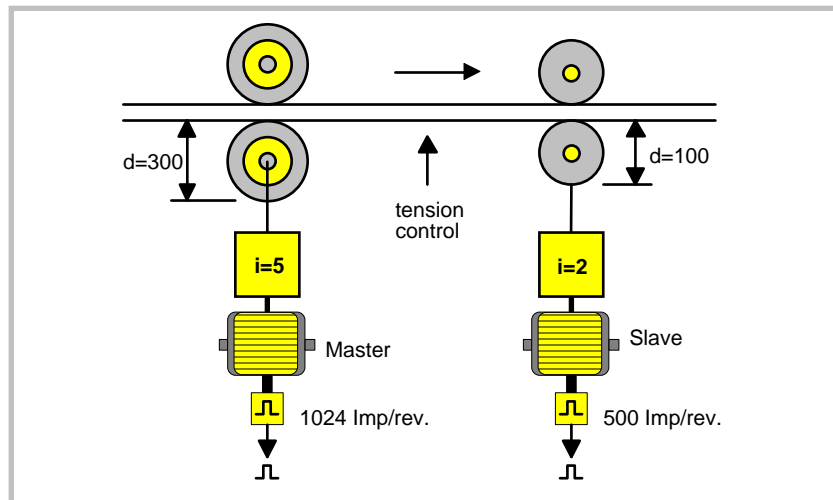

Fig. 5

With one full revolution of the master roll, we receive $5 \times 1024 = 5120$ impulses from the master encoder. If the material must pass the roll **without** any tension, the slave roll would exactly need 3 revolutions at the same time. So we will get $3 \times 2 \times 500 = 3000$ impulses from the slave encoder. This means, we need **3000 slave pulses for every 5120 master pulses** to operate synchronously.

We subsequently have to set up Factor 1 and Factor 2 so, that the relation

$$5120 \times \text{Factor 1} = 3000 \times \text{Factor 2}$$

becomes true. The simplest way to do this, is to set the factors exactly to the digital value of the impulse numbers from the opposite side, i. e. Factor 1 = 0.3000 and Factor 2 = 0.5120. Then, the synchronous condition will absolutely match the formula, **but** there could be little comprehension from the operator, that he needs to set a value of 0.3000 on his terminal to have tension-free synchronism. He would understand more clearly, if the setting was 1.0000.

So, we need to use the formula with different figures:

$$5120 \times 1,0000 = 3000 \times \text{Factor 2}$$

As a result we find that Factor 2 must be $5120 : 3000 = 1.7067$. This setting calibrates the Factor 1 to comprehensible "user units" ($1.0000 = \text{no tension}$, $1.0375 = 3,75\% \text{ tension}$). The same result can be achieved when using the parameter "F1-Scaling Factor" to scale the values transmitted from the operator terminal.

Hint 1: It is best, whenever possible, to have Factor 1 and Factor 2 in a numeric range of 0.1000 - 2.0000. This allows the BY to use the full 12 Bit resolution of all D/A converters. When, for example, the factor calculation results in figures like 4.5000 and 7.8000, it is better to set 0.4500 and 0.7800 (or 0.9000 and 1.5600 or any other proportional values within the recommended range) to ensure best operation.

Hint 2: Whenever a **positional synchronisation** is needed, cumulative errors must be avoided by proper factor setting (factors can only be set with 4 digits to the right of decimal point).

If, i.e., a ratio of 16 : 17 would be required, never use the decimal expression of 0.**9411**7647....as Factor 1, because the non-entered digits will accumulate to give positional errors after a short time. This can be completely avoided when using factors like 1.6000 and 1.7000 (or also 0.8000 : 0.8500 etc.).

This hint need not be observed with **speed synchronisation** alone, because speed errors will remain undetectably small.

Hint 3: It is best to choose the ppr number of the encoders to receive frequencies in approx. the same range on both sides. It can i.e. become difficult to synchronise 100 Hz on one side with 80kHz on the other side.

4. **Ratio Change during Operation**

The speed ratio can be changed at any time by changing Fact1. Changing Fact1 from 1.0000 to 2.0000 will result in double slave speed.

The **speed transition** can be sudden or soft. The slave approaches it's new speed via an adjustable **S-shape ramp**. See parameter "Ramp 1" on page 23 of this manual.

With some applications, the **numerical value** of the speed ratio is **unknown** and the operator has to find it out by his own observation and **feeling**. For these applications, the BY 150 provides a "**Factor-Tuning**" function. Starting from the programmed basic value, Fact1 can be incremented or decremented via external pushbuttons "+" and "-". While keeping the button down, Fact 1 will increase or decrease with an adjustable tuning speed. When releasing the button, the actual ratio will be active to keep the drive speeds with digital accuracy.

To avoid wrong operator settings, the remotely accessible range of Fact1 can be limited by the parameters Fact1-min and Fact1-max.

5. **Change of Phase and Relative Position**

The relative phase situation between Master and Slave is normally set by the state upon power-up or with the last Reset signal (in index modes, the index edges and the programmed phase displacement define the relative position, see chapter 6.)

During all the operation, this initial phase condition is held without any errors, unless the operator uses one of three available phase adjustment facilities:

5.1. **Phase Adjustment by Timer Trimming**

This function, activated by the "Trim +" and "Trim -" inputs, provides a temporary higher or lower slave speed which will result in a phase displacement between the motor shafts. When releasing the trim buttons, the drives will synchronise again in their new relative position.

The **differential trim speed** is adjustable and operates as a speed addition or a subtraction to the slave, **without consideration of the actual absolute speed**. This is why the trim function can also be used at standstill, to move the slave into a convenient start-up position. As an example, the trim function is ideal for a multi colour print machine, to adjust the register marks.

5.2. Phase Adjustment by External Impulse Stepping

In this operation mode, the trim inputs operate as edge triggered impulse inputs and each positive transition will displace the slave shaft position exactly by one encoder impulse (Trim+ = forward, Trim- = reverse). This function allows, for example, a PLC control to step the phase to different, **fully repeatable positions** during operation or standstill, in accordance with different product dimensions on a machine. Also is it possible to operate the BY 150 like a **differential gearbox**, because the slave can move according to the **sum** or **difference** of two other drive speeds.

5.3. Phase Adjustment by Digital Phase Offset

The unit provides an Offset register which can be set to a desired number of encoder impulses. Every rising edge at the "Index Master" input will displace the actual phase forward by the number of offset impulses, and every rising edge at the "Index Slave" input will do the same to the other direction. By this function, the phase situation can be stepped forward or reverse by the pitch set to the offset register.

6. Index Registration and Control

Index or marker pulses are used to automatically set the drives or the material into a correct relative position. It is possible to **either** use the zero pulse inputs on the encoder terminals (Z and \bar{Z} , 5V TTL) **or** the index inputs on the PI/PO- connector (10...30V), and register "Index Mode" selects which inputs are in use.

It is possible to enter the phase displacement between the marker pulses by BCD parallel input or by PC or host computer, and to change it at any time, at standstill or on the fly (Register "Phase offset").

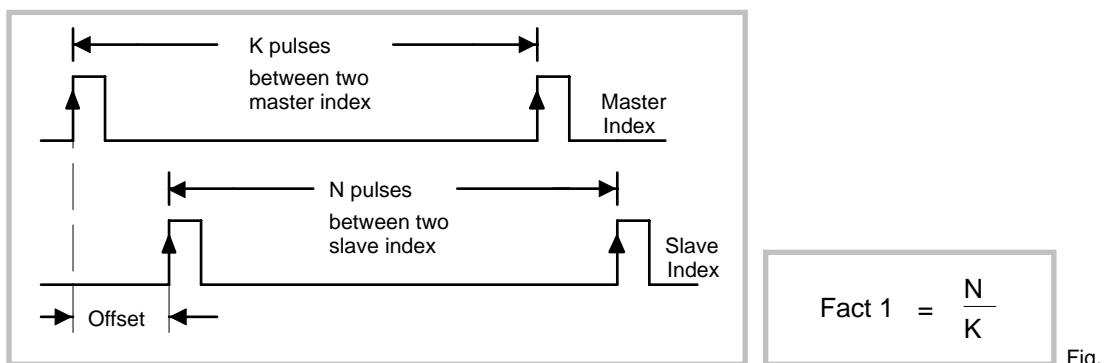

6

The parameter **Factor 1** is used to adapt different impulse numbers **K** and **N** on both encoders. The number of slave impulses **N** must be set to register "Impulse Index".

The formula Fig. 6 shows how to calculate Factor 1. The offset needs to be set directly as "number of slave impulses" and has a setting range from -N to +N which means -360° to +360° of displacement.

Between two marker signals, the drives operate in a normal digital synchronism. The master impulses are scaled with **Factor 1**, but the slave impulses count with a **fixed factor of 1,0000** in Index mode.

A positive edge on the slave index input starts a phase comparison with the previous master index and a correction, if not coincident to the offset **M**. **Additional phase adjustment**, as described under sections 5.1 and 5.2, is also possible in index mode, i. e., starting from an initial

phase position, the final **phase** can be easily **tuned**, by pushbuttons or PLC, if applicable. The new phase can be restored to the phase offset register by a store command..

As a special, the BY 150 can even operate with **different numbers of marker pulses** on both sides. This is possible due to the following features:

- a. The master index input is equipped with a programmable index divider , which, for example, allows sampling of only each 5th marker pulse.
- b. The slave index input is locked in a way, that it is active only once after each valid master marker pulse.

This enables the user, in terms of one machine cycle, to have for example 5 master markers and 3 slave markers. Upon start up, the BY 150 checks for the nearest marker couple and sets them in line. Subsequently, each 5th master index will be checked with each 3rd slave index.

Operation mode 8 provides a fully unlocked function of the index inputs and every couple of marker impulses will cause a correction, no matter if the master leads the slave index or vice-versa.

This mode needs setting of a "maximum index error" to the "Impulse Index" register (setting in slave encoder increments). The differential speed to correct for the index error can be set by register "Trimm speed".

Mode 8 is perfectly suitable for compensation of wheel slip with large cranes (reference marks on the rails, see special description "Version B25") and to equalise different distance between products when passing from one conveyor to another.

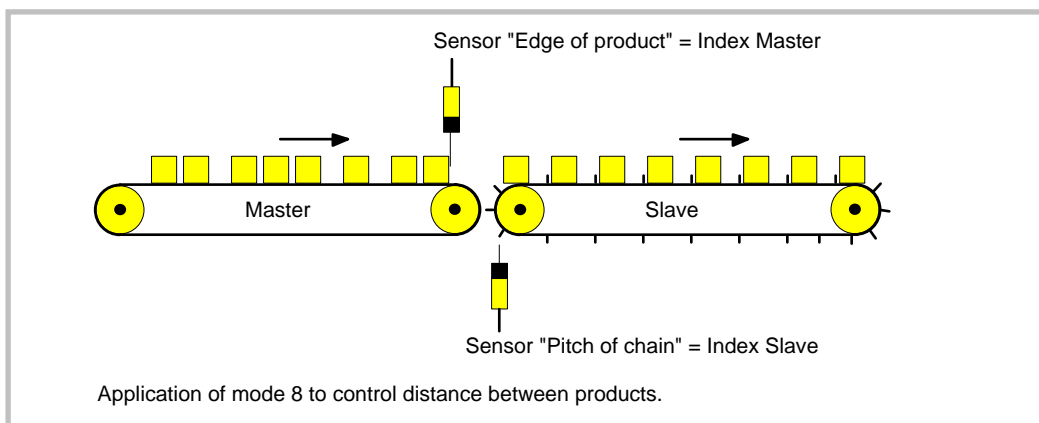

Fig. 7

7. Wiring and Screening

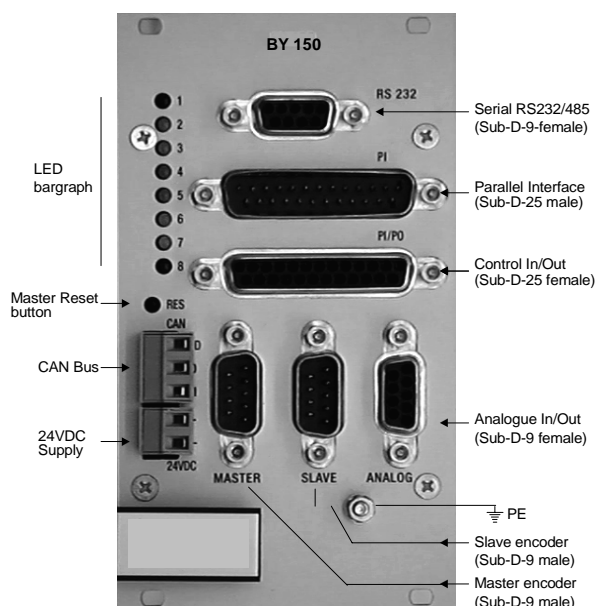

Fig. 8

Fig. 8 shows the connectors available on the front plate and Fig. 9 shows a minimum configuration with the BY 150 synchroniser.

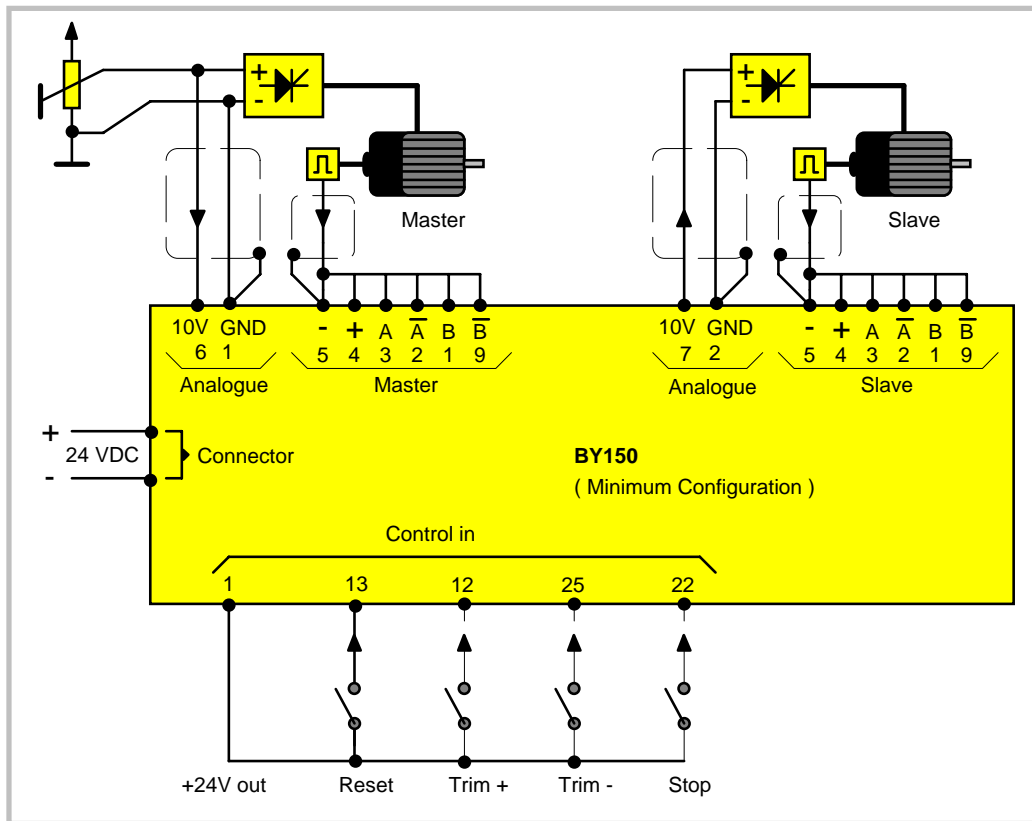

Fig. 9

For reasons of proper screening, it is a must to follow the subsequent instructions.

Where you don't exactly observe these grounding and screening rules, it is almost for sure that you will have problems later!

- The minus wire of the power supply must be connected to the grounding screw on the front plate of the BY150 controller with a short wire of at least 0.75 mm².

On site of the power supply, the minus output must be earthed.

Where the wires between power unit and BY150 controllers are longer than e.g. 1 meter, it is advisable to ground the front plate of the controller again by a separate wire, on the shortest way possible.

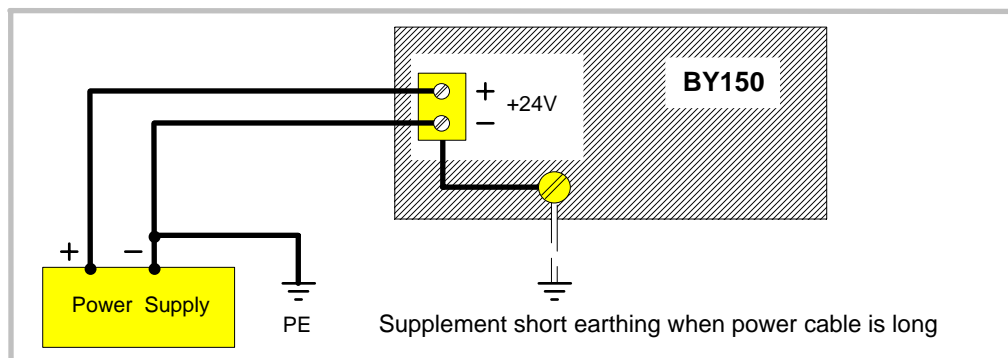

Fig.10

- b. All screens on the controller side must be connected to the housing of the corresponding Sub-D-connector. This is valid for encoder cables, analogue output and PI or PO lines. Where you use Sub-D-connectors with a plastic housing, you must solder the screen to the metallic frame of the connector. **At any time you must be sure the screen gets a proper contact to the front facia of the unit when connected to the controller.**

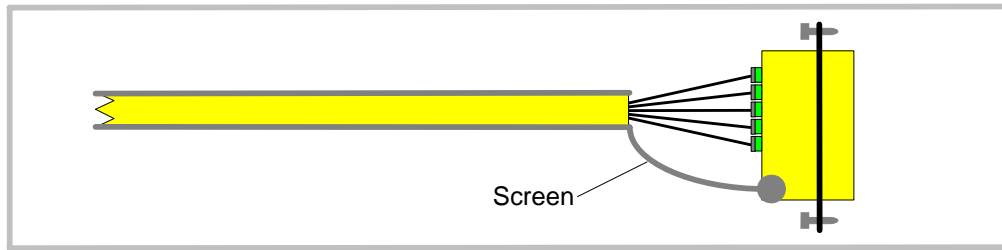

Fig.11

- c. When **encoder cables** are interrupted by terminal boxes or intermediate connectors on their way from the controller to the encoder, you must connect the screen to the Minus wire of the encoder supply there, but never to earth potential again!!.

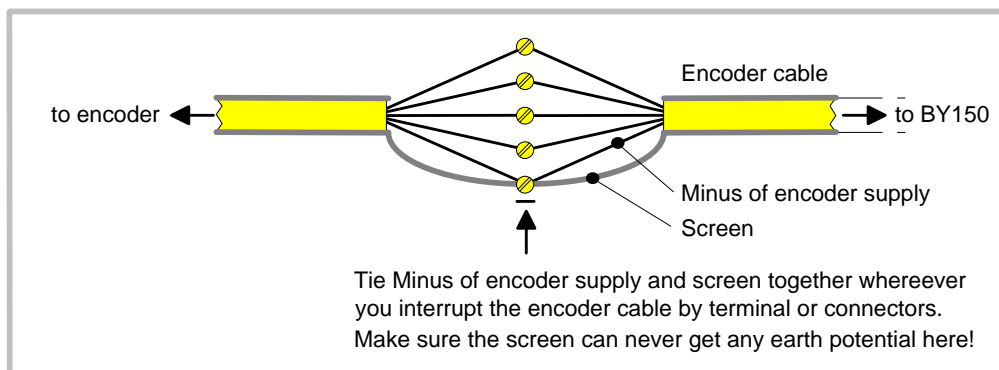

Fig.12

- d. When the cable arrives at the encoder site, the screen must again be connected to the Minus wire of the encoder supply, but not at all grounded to earth. In general, there are two types of encoder connections:

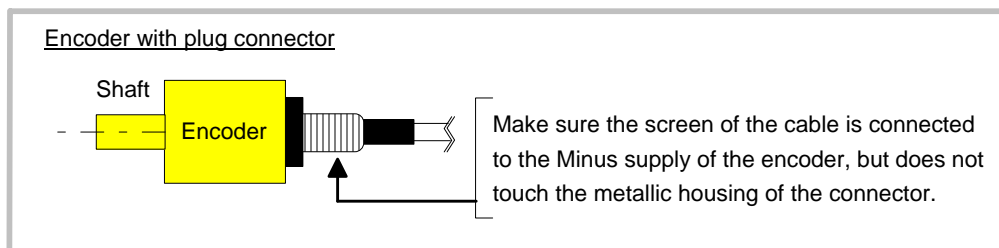

Fig.13

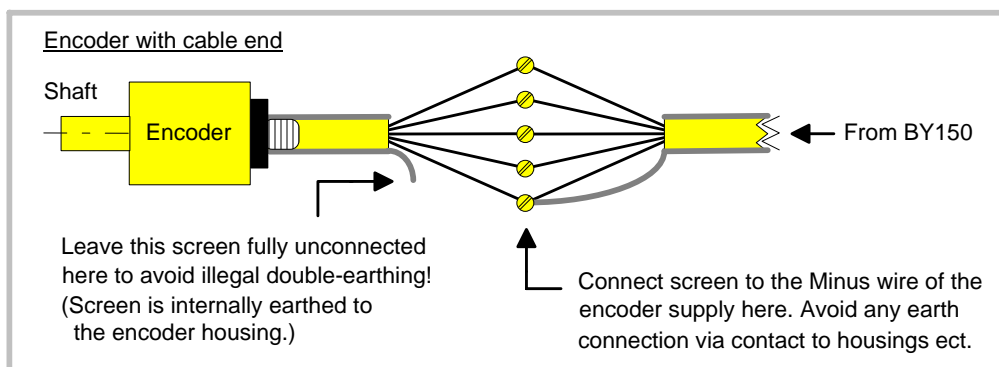

Fig.14

- e. With **all other cables** like analogue output, control or parallel output, put the screen to the metal connector housing on the BY150 side and leave it **unconnected on its peripheral side**. Again avoid double earthing. The only place where the screen is earthed must be the front plate of the unit!

Example : Analogue speed reference signal

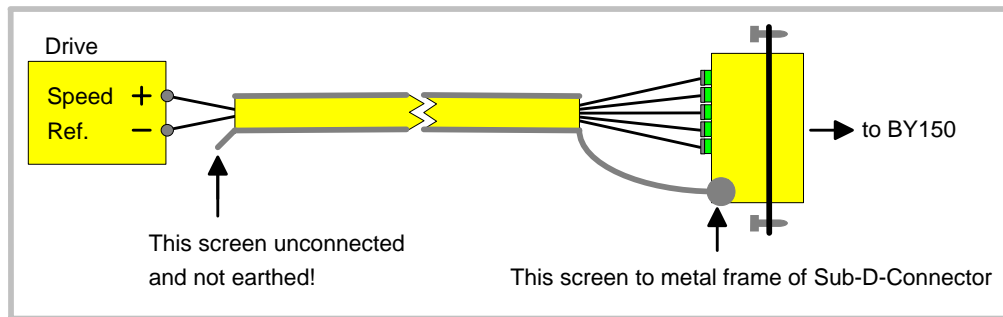

Fig.14

All cables connected to the BY150 should be separated from motor cables and other powers lines. It is indispensable to use screened motor cables.

7.1 Encoders

The unit only accepts TTL impulse signals (5V, RS 422) or similar from an encoder simulation (resolver). It is essential to connect the channels A, \bar{A} , B, \bar{B} . The Z and \bar{Z} marker inputs must only be connected when you use one of the index operation modes.

Where you find you are working with existing 10 - 30 Volt encoder signals which feature only A / B / Z signals, the PU 202 converter should be used to gain full complementary signals in line with RS 422 standards.

An auxiliary voltage of **5,0 V (max. 400 mA)** is available on the connector plugs “**Master**“ and “**Slave**“, for easy supply of the encoders. This voltage uses the same GND as the power supply, the digital inputs and the analogue output. Both encoder connectors on the unit are Sub - D - 9 pin, male.

Fig. 4 and Fig. 5 show the encoder connections and the principle of the input circuit. All impulse inputs are driven by high speed optocouplers.

When connecting the encoders it is not important to wire the A and B signals to produce the correct counting direction. The direction can be determined in the setup menu.

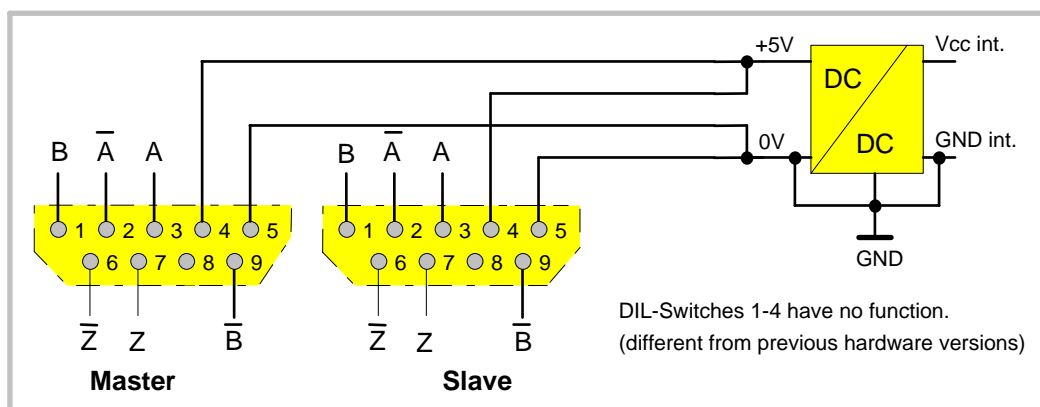

Fig.15

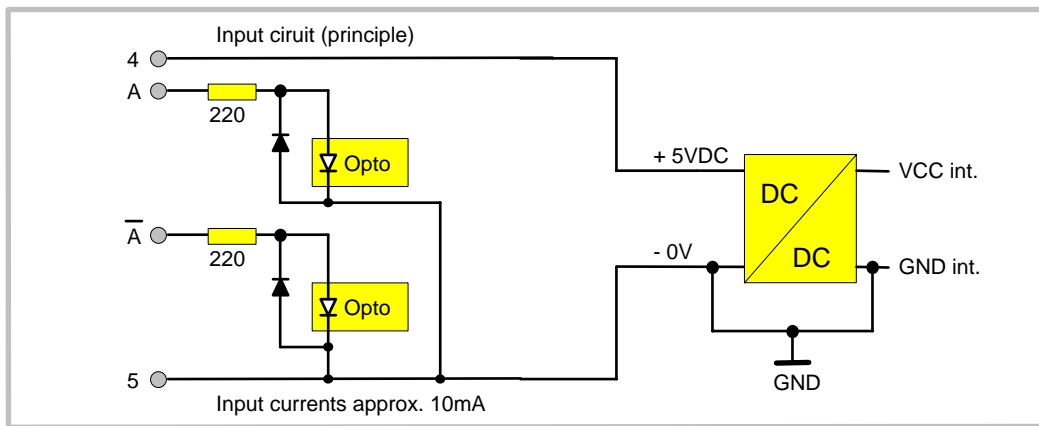

Fig.16

Important

- **With encoders, supplied by the BY 150:**
Connector pins 4 and 5 provide the encoder supply.
- **With encoders, supplied by an external source, or when an encoder simulation from the drive is used (Common GND operation)**
Use connector pin 5 as common zero Volt potential.
- For fully **potential-free operation:**
Connect **only** A, \bar{A} and B, \bar{B} and **leave terminal 5 (Common) unconnected.**

For reason of best noise immunity, we recommend to use potential- free operation wherever you have line driver signals with remote supply.

Warnings:

- **Pin 4 of the Master and Slave encoder connectors is a supply output and you must never apply external voltage to this pin. Serious damage of the controller would be the result!**
- Where you use one **common encoder for feedback of the drive and feedback for the BY150 at the same time**, there may come up interference problems. You can use a GV150 impulse splitter to eliminate any kind of problems. In most applications, the common encoder would also work fine when it is **supplied by the drive** and the BY150 operates in fully differential mode like shown.

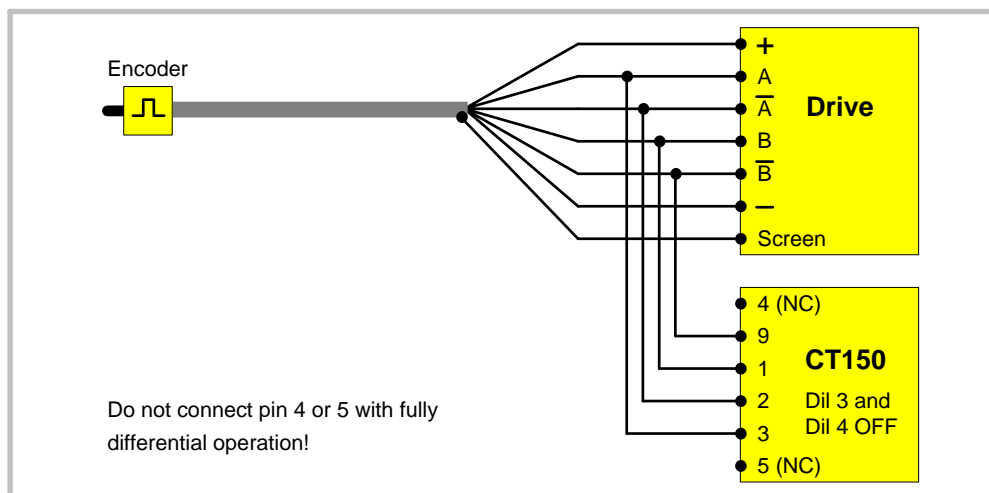

Fig.17

DIL switches S1 / 5 - 8 provide the selection of the encoder edge counting. It is possible with complementary signals to count with times 1, 2, or 4 without any fear of miscounting. The selection always applies separately to the master **and** the slave input signals.

Master:		
DIL-Pos. 5	DIL-Pos. 6	edge count
ON	ON	x1
OFF	ON	x2
ON	OFF	x4
OFF	OFF	counter disabled

Slave:		
DIL-Pos. 7	DIL-Pos. 8	edge count
ON	ON	x1
OFF	ON	x2
ON	OFF	x4
OFF	OFF	counter disabled

Please note, that

- the maximum frequency of the BY 150 refers to the total **number of edges** counted, i.e. 300 kHz (x1) or 150 kHz (x2) or 75 kHz (x4).
- impulse numbers, to be entered upon setup, also refer to the total **number of edges** counted, i. e. the entry data must be doubled with (x2) etc.
- When possible, you should set the switches in a way to produce approximately similar impulse numbers on Master and Slave side to achieve best operation. i.e. 4096 impulses x 1 on the Masterside and 1000 impulses x 4 on the Slave side.

7.2 Analogue Connections

All the analogue input and output signals can be found on the 9-Pin Sub-D connector (female) marked as "Analog" on the front plate. **The Analogue common GND is internally connected to the minus of the 24 VDC supply. All analogue levels are in range +/- 10 Volts.**

When you use the **digital feed- forward** mode, you must only connect **pin 7** which is the analogue output for the slave drive speed reference.

When you use the **analogue feed- forward** mode, you must apply a 0 - 10 V analogue signal proportional to the Master speed to **pin 6**.

Pin 4, 5, 8 and 9 are for special purpose and must normally remain unconnected.

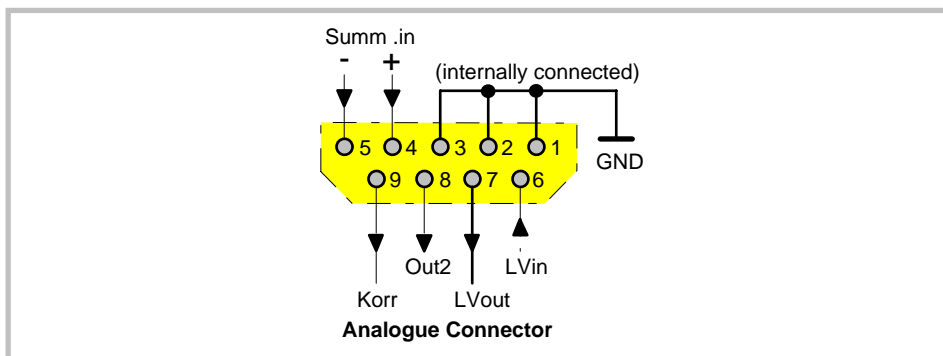

Fig 18

With a few applications it can be an advantage to wire the analogue speed reference in a balance mode like shown, where we do no more have a "Master" and a "Slave", but both drives are equal and support one another with inverse reaction when making corrections.

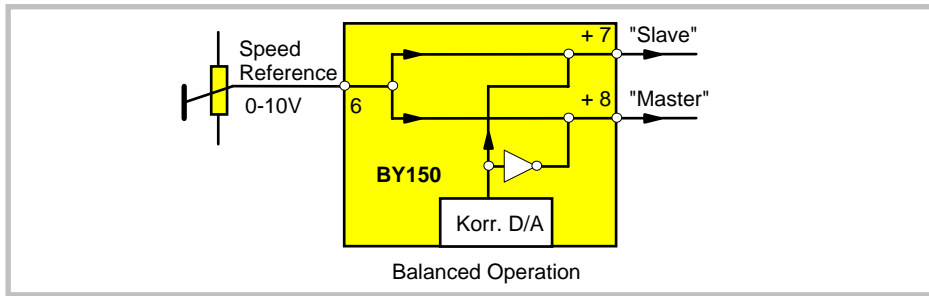

Fig. 19

This type of operation is ideally suited to synchronisation of drives with vastly differing loads. It is also useful for index pulse tracking when both drives move in the opposite direction to the synchronisation position. It also has advantages in hydraulic applications, when servo valves are used instead of electric drives.

7.3 Power Supply

The BY150 operates from an un stabilised 24 VDC supply (+/- 25%), however, the voltage including ripple should not exceed the following limits (18 V...30 V). The supply of the BY150 is both electrically and mechanically protected against wrong polarity misconnection by protection diodes and a special plug.

Warning:

At pin 1 of the "PI" connector and pin 1 of the "PI/PO" connector, a +24V output is available for easier wiring of input and output supplies. This voltage is taken from behind of a current limiting resistor. Short circuiting these outputs to GND can burn the resistor or internal printed lines.

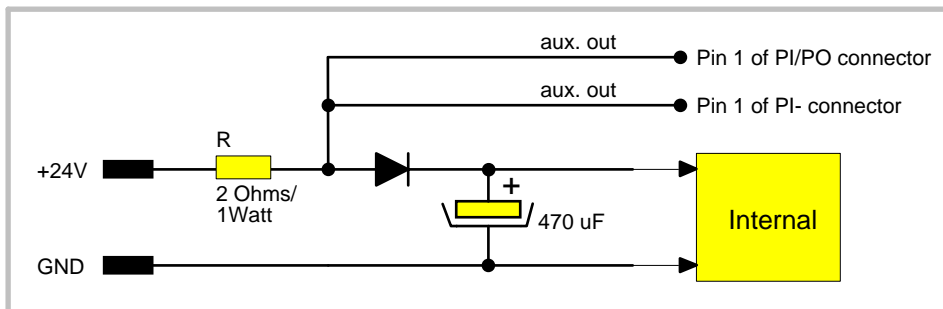

Fig.20

7.4 Parallel Interface

The interface provides remote setting of operational and configuration registers. It receives BCD or binary data (selectable) from a remote thumbwheel switch or PLC control. There are four binary coded select lines which provide up to 16 addresses being accessible, via 20 data lines. The register parameters are stored in the following manner:

- a. Store the parallel data upon a strobe pulse. The data is then latched into the internal buffer, without affecting the synchrocontrol operation at this point.
- b. Activate data upon an input pulse. All the data stored in the buffer is loaded and executed.

It is easy to see how 16 external registers may be easily loaded into the BY 150.

The connection of the parallel interface is a 25 pin Sub-D connector (male) which is marked as "PI" on the front facia.

All inputs are fully PLC compatible. All signals refer to GND and the minus potential of the supply.

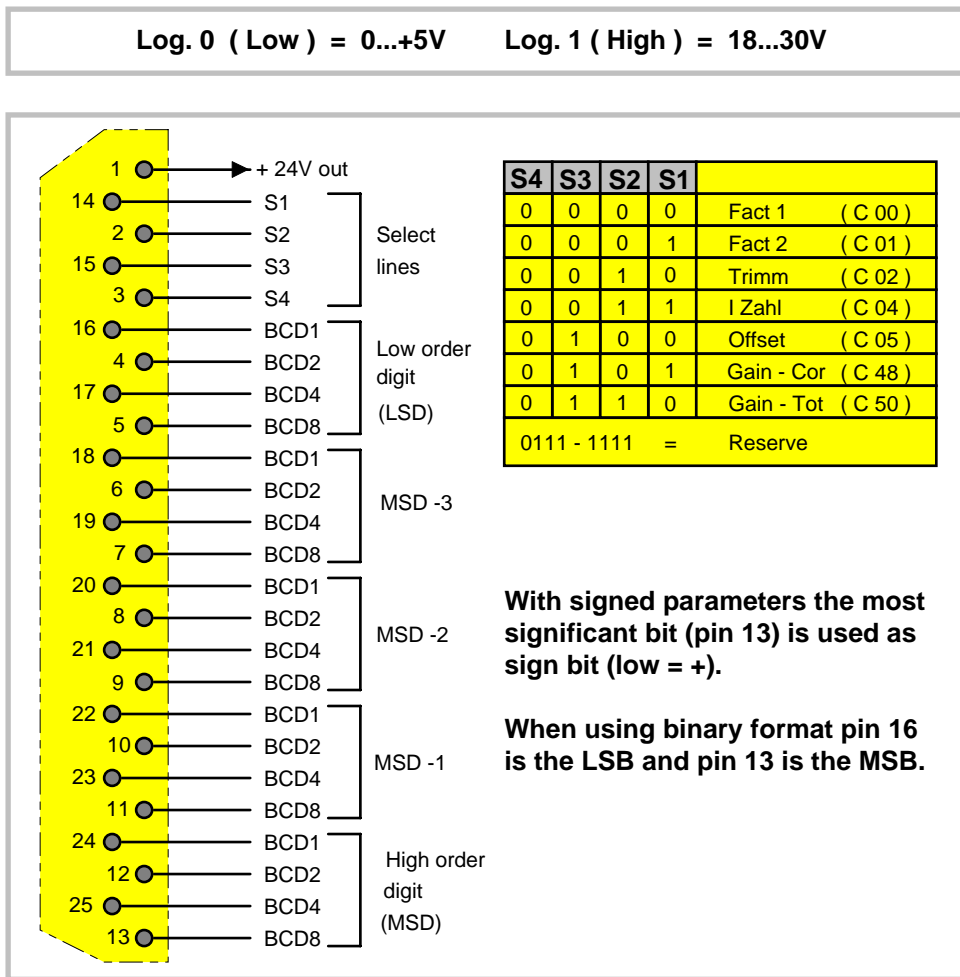

Fig. 21

Important Advice

Upon power up, the unit loads the full register set stored in its EEPROM. Data transmitted from the parallel and/or serial interface will overwrite the operational RAM-data, but not the corresponding EEPROM registers. As a result, when powering up, any parallel or serial data will be replaced by EEPROM data, until it is overwritten again.

The RAM data however can be restored to the EEPROM at any time by parallel or serial command.

Parallel interface operations must keep the following timing conditions:

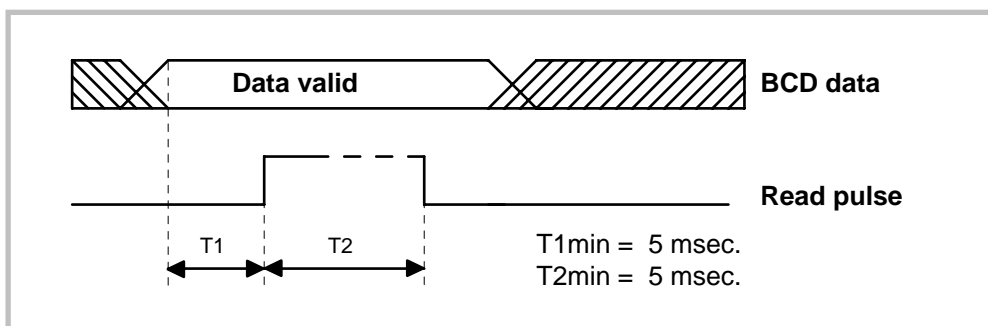

Fig. 22

Data latch occurs with the positive transition of the strobe pulse. Data lines must be in a valid state at least 5 msec prior to the strobe, and remain present for an additional 5 msec while the data is read. There is no upper limit for T1 and T2.

7.5 Control IN/OUT Port

There are 12 control input lines and 8 control output lines available on the 25 Pin Sub-D connector (female). This is marked on the fascia PI/PO. All the inputs are the same as the parallel inputs. All the outputs are opto-isolated transistor outputs which are PLC compatible.

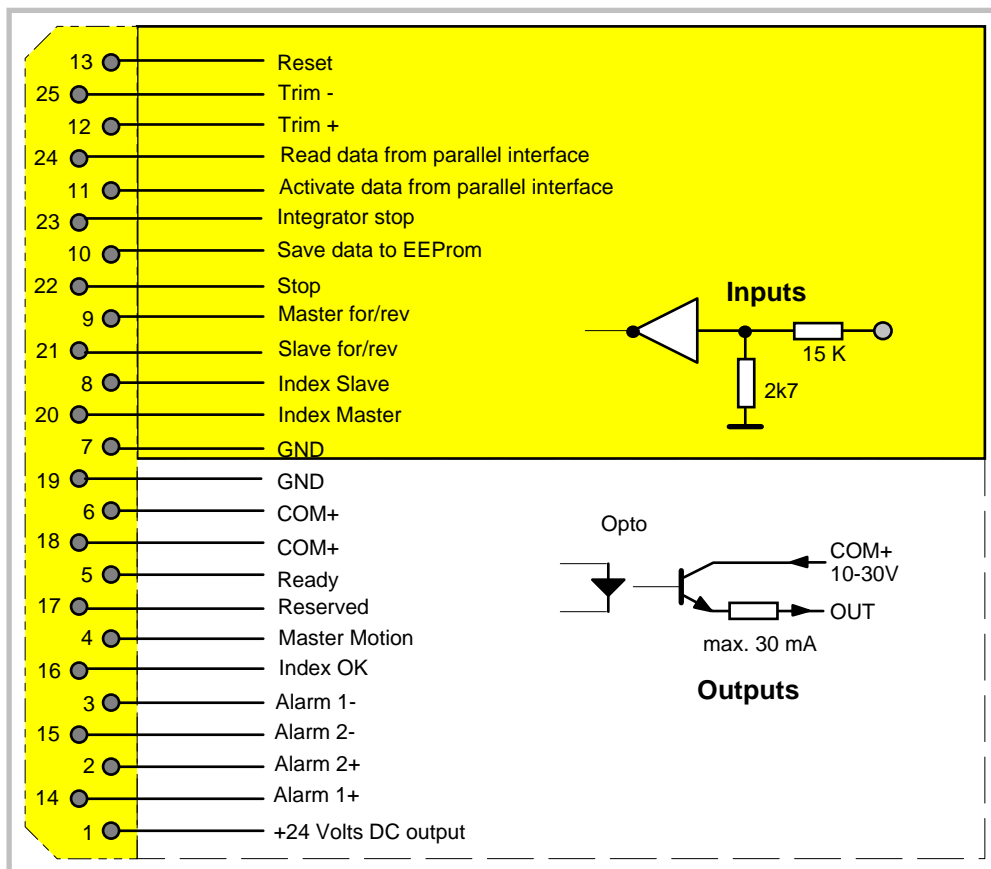

Fig. 23

Inputs:

Reset (13):

Sets the internal differential counter and the analogue correction signal to zero and holds the LED bar graph in its green centre position. Both drives run solely in analogue synchronisation whilst held. This is an operational reset, different from the general master reset on the front (see 21.)

Trim- (25):

Adjusts the angular position of the slave to lag the master, in the chosen direction. Provides static or dynamic operation (see 9. "Mode")

Trim+ (12):

As above but adjusts the slave to lead the master.

Read Data (24):

Reads values of BCD or Binary code on parallel input. These values are stored in 16 separate buffer memories, as selected. This data is not activated until the following input is made.

Activate Data (11):

A **rising** edge of this input transfers the data from the buffer memory to the operating memory.

N.B It is permissible to activate both "Read" and "Activate" inputs at the same time. Thus for instance, a common input can be used to enter a new F1 factor.

Integrator Stop (23):

This input sets the phase integrator to 0. This prevents the integrator from building up error when the drives are stopped, but not in a perfect synchronous position. This prevents any leap in speed on restart.

Restore data to EEPROM (10):

A rising edge on this input will restore all actual operating data to the EEPROM and upon next power-up the data set will be available again. **The BY 150 is out of operation for a time of 100 msec after activation of the restore command.**

Stop (22):

When going "High", the slave will leave the synchronous state and decelerate to standstill, following an **adjustable S-shape ramp**. When going "low" again, the motor uses the same ramp to restart and to synchronise again with the master. See parameter "Stop-Rmp."

Master for/rev (9), Slave for/rev (21):

These inputs must remain open, when **no reversals** are scheduled. They also remain unconnected, when both master and slave are **4-quadrant drives** with **common reversal** at a time (Both forward or both reverse). All other applications require to set these inputs in accordance to the actual direction of rotation and the BY 150 will automatically respect analogue polarity and digital counting sense.

Forward	=	Input "Low"
Reverse	=	Input "High"

This function needs a correct specification of the drive types in use (4- quadrant or switch reversal, see parameter "D-Config"). The drives then can individually operate in any direction of rotation.

After changing the signal state on inputs 9 and 21, the Reset input 13 must be cycled.

Index Slave (8), Index Master (20):

These 10-30 V inputs allow the use of marker pulses from proximity switches or photocells, when the encoder index pulses are not suitable. Depending on the "Mode" selected, they provide functions like **index registration**, **phase offset** actuation and **factor tuning** (increment or decrement Fact 1).

The inputs are edge-triggered (positive transition) and must be activated by setting the Index Mode register.

Control Outputs**Ready (5):**

This announces that the unit is ready to run. On power up, this output is "Low" for about three seconds to allow the power supply to settle, and then switches to "High".

Warning:

When "High", the unit could not detect a system fault itself, but this is not a guarantee for fault-free operation!

Master Motion (4):

Indicates that the Master moves (High) or stands still (Low), according to the standstill definition of the "MCFrequency" register.

Index o. k. (16):

When High the Slave index pulses are inside the window set by parameter "Index Window", with respect to the Master index pulse and the phase displacement set to "Phase Offset".

Alarm 1- (3), Alarm 1+(14):

The alarm output signals that the preset tolerance band has been exceeded in one direction or the other, as specified by the parameter "Alarm1".

Alarm 2- (15), Alarm 2+ (2):

As above, but with respect to the "Alarm2" preset. In general, Alarm 1 is used to indicate slight temporary phase errors, while the synchronisation is still fully active and Alarm 2 is used to signal "out of synchronisation". The reason for Alarm outputs can be sudden load changes, current limits or serious electrical, mechanical or peripheral problems.

If it is required to have isolated outputs, it is necessary to connect an external supply (+5...+30V) to one of the "Com +" inputs. For non-isolated outputs, it is possible to use the internal +24V supply (Pin 1) and connect this to "Com +" (Pin 6).

8. The Serial Port

The RS 232 serial link can be used for two purposes:

The unit includes a serial RS232 and a RS485 interface, both accessible by the Sub-D-9 connector marked „RS232“.

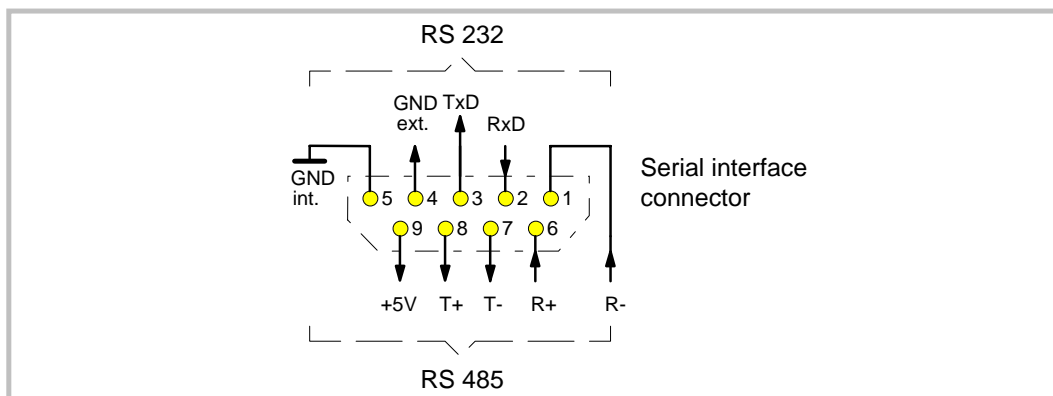

Fig.24

To run the OS 3.0 operator software with your PC by RS232, your PC must be connected to the BY150 unit like shown:

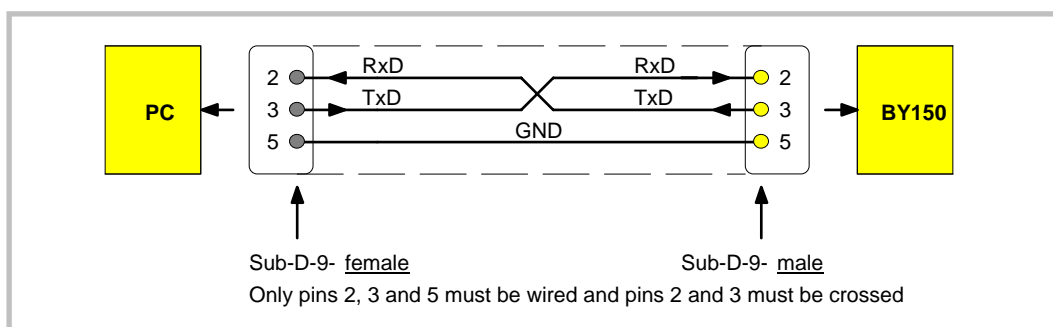

Fig.25

Please make sure your PC serial cable uses only the three pins shown. When also other pins are connected, this will cause interference with the RS485 pins and the PC communication will not work.

When using the RS485 interface, you can serve up to 32 different bus participants in either 2-wire or 4-wire transmissions mode. The subsequent figures show, as an example, how to run a TX720 operator terminal with a BY150 unit and other controllers.

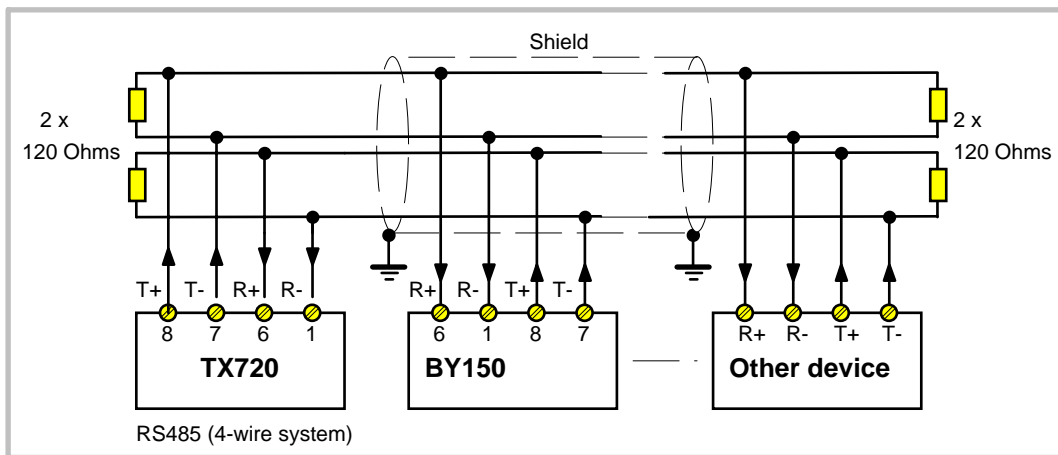

Fig.26

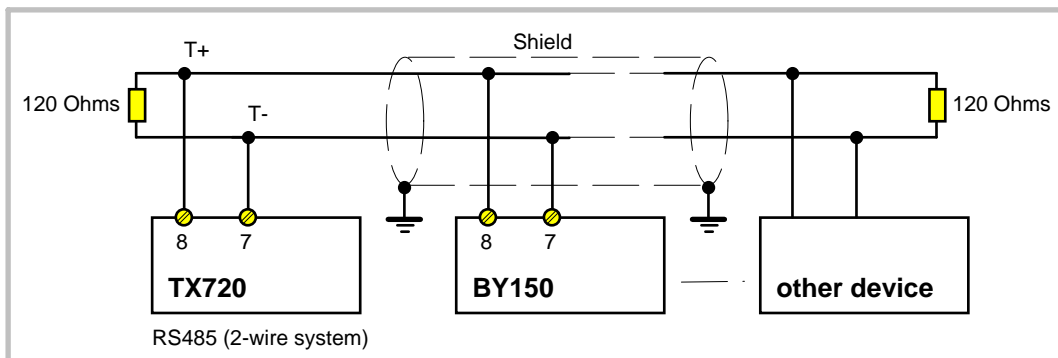

Fig.26

A detailed **description of the serial protocol** is available upon request or can be downloaded from the **DOWNLOAD** site of the motrona homepage (www.motrona.com, document name: „Serpro“)

9. How to operate the Keypad (not needed with PC setup)

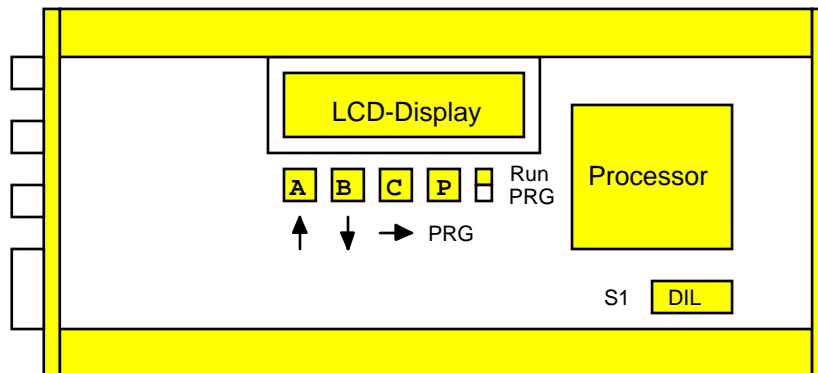

Fig.27

To access the operator PCB, remove right hand side plate.





The on board setting controls comprise an LCD display, 4 small buttons and a sliding switch. When the switch is selected to "Run", the LCD permanently displays the software version of the program and the buttons A, B, C and P have no function.

Programming by the on board setting controls requires the sliding switch to be slid to "PRG". For external PC setting it must however be in the „Run“ position.

The buttons have the following control functions (Cursor highlights the register):

- Button A:** Scrolls register down; scrolls menu forward and also increments the highlighted digit.
- Button B:** Scrolls registers up; scrolls menu backward and also decrements the highlighted digit.
- Button C:** Returns from register to menu titles; increments highlighted digits to the right, (or from full right to full left).
- Button P:** Enters from menu to registers; changes register from text to value and back to text again. Stores actual data to the EEPROM.

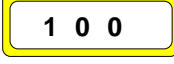
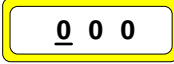
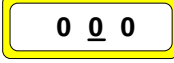
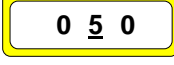
The following example shows how to set the "Trim" register of the Data IN menu (see register table).

Action	LCD
• Slide the switch to "PRG"	
• Select the Data IN Menu by pressing "P"	
• Press "A" several times until the LCD shows "Trimm"	
• Select the Trim register by P and read the actual setting (e.g.100)	
• Change setting to e.g. 50 msec like shown:	
• Key B decrements digit highlighted by cursor	
• Key C shifts cursor right	
• Key A increments highlighted digit. Press A 5 times.	
• Press P to store the new value	

When you slide the switch back to "RUN", you read again "BY15012A" and the unit is ready to operate.

When you press "C" instead, you come back to "DATA IN" etc.

Please note:

The unit is unable to operate or to make serial communication while the slide switch is in the "PRG" position!

		B ← → A					
		Data In	Set - up	Adjust	Testprog		
	C00	Fact 1	C40	Mode	Gain - Cor	Mast - Dir	
	C01	Fact 2	C41	LV - Calc	Gain - Tot	Slav - Dir	
	C02	Trimm	C42	D - Config		Offs - Cor	
	C03	Int - Time	C43	PI - Form		Gain - Cor	
	C04*	Imp-Ind.	C44	Add - Cor		Offs - Tot	
	C05	Offset	C90	Unit - Nr.		Gain - Tot	
	C06	Alarm 1	C91	Baud - Rat		LED - PO	
	C07	Alarm 2	C92	Ser - Form		Cont - IN	
	C08	Ramp	C93	Bus-Add		PI - IN	
	C09	Stop - Rmp	C94	Bus-Baud		Ind-Mast	
	C10	Cor - Divi	C95	Bus-Conf		Ind-Slav	
	C11*	Phaseadj	C96	BusTxPar		DAC-Cor	
	C12*	Ind - Divi	C97	BusRxPar		DAC-Tot	
	C13	F1 Scal	C45	Mast - Dir		Factory	
	C14	Fac1-min	C46	Slav - Dir			
	C15	Fac1-max	C47	Offs - Cor			
	C16*	Ind-Wind	C48	Gain - Cor			
	C17	Mast-MC	C49	Offs - Tot			
	C18*	Ind-Mode	C50	Gain - Tot			
	C19*	Max Corr					
C20	SampTime						

* Only relevant with Index operation

Fig. 28

10. Modes of Operation

Prior to explaining details about the registers and their functions, the various modes of operation are described first for better comprehension. There are eight modes selectable by the mode register, which specifically set up the function of the trim inputs and the index inputs.

General instructions have already been given in sections 5 and 6. The mode also allows scaling of the ratio setting in a +/- 99,99% format. All modes are listed in the table below:





Mode	Trim inputs	Index inputs	Impulse scaling
1	Phase trim by internal trim speed 	No function	Fact 1 : Fact 2
2	Phase trim by internal trim speed 	Index control with phase offset 	Fact 1 : 1,0000
3	Phase trim by internal trim speed 	Index Master $\int =$ Forward offset displacement Index Slave $\int =$ Reverse offset displacement	Fact 1 : Fact 2
4	Phase trim by internal trim speed 	Index Master  Increment Fact 1 Index Slave  Decrement Fact 1	Fact 1 : Fact 2
5	Phase trim by external pulse source 	No function	Fact 1 : Fact 2
6	Phase trim by external pulse source 	Index control with phase offset 	Fact 1 : 1,0000
7	Phase trim by internal trim speed 	No function	Fact 1 = +/- 99,99% 0 % \wedge 1,0000
8	Phase trim by internal trim speed 	Unlocked Index operation	Fact 1 : 1,0000

Fig. 29

11 Data In Menu

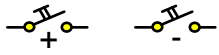
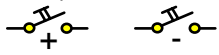
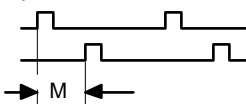
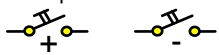
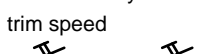
Fact 1:

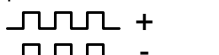
Pulse multiplication for the master encoder. Range 0.0001 - 9.9999 (In mode 7: +/- 99.99%, referring to a basic ratio of 1.0000 = 0%)

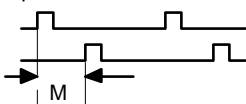
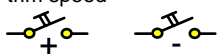
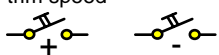
Fact 2:

Pulse multiplication for the slave encoder. Range 0.0001 - 9.9999. In modes 2 and 6, the setting is automatically replaced by a fixed 1.0000 scaling.

Trim:

Rate of change, to be entered as a number of software cycles (1 cycle = 100 µsec), for

- a. phase trimming, when the +/- trim inputs are activated in modes 1 - 4 and 7 – 8.
- b. factor tuning, i.e. speed for incrementing/decrementing Fact1 (mode 4)
- c. offset displacement, i.e. additional speed to change from previous to new phase position (mode 3).

Range of setting: 001 - 999 cycles per increment.

Example:

In mode 1, with Trim set to 001, each 100 µsec the phase will be displaced by one encoder increment (= 10.000 increments each second), and with Trim set to 050, the processor will take 50 cycles for one increment.

INT-Time:

Time constant for the phase integrator, which avoids positional errors, is also to be entered as a number of software cycles. Range 000 - 999

Setting 000: No integration, proportional control only **Setting 020:** Integrator needs 20 cycles (=2 msec) to compensate for one increment etc.

In mode 2, 6 and 8 (index control), the integrator is automatically switched off.

Imp-Ind:

For marker synchronisation only. Number N of pulses between slave markers (see 6.). Range 1 – 999.999. In mode 8, the maximum occurring index error must be set here.

Offset:

Number of slave encoder pulses that the slave should displace with respect to the master. With modes 2 and 6, this is equivalent to the phase displacement **M**, in mode 3 it defines the distance of displacement upon external command. Range: -999.999 ... +999.999.

Alarm 1:

Set tolerance window. Can be set between 0000 - 9999 bits of difference. Typical setting 30. Affects the Alarm 1 outputs when out of tolerance.

Alarm 2:

Normally used as "out of synchronisation" limit. Can be set between 0000 - 9999 and affects the Alarm 2 outputs: Typical setting at 1024, at which point the correction signal is saturated.

Ramp:

Ramp time for changes of speed ratio. Range 0 - 99,9 sec.. Setting Ramp to zero results in abrupt change of the slave speed. All other settings provide a sin² transition from one ratio to next within the preset time, independant of the difference between initial and final speed.

Stop-Ramp:

Ramp time when using the Stop input. Range 0 - 99.9 sec. Setting Stop-Ramp to zero results in abrupt deceleration or acceleration upon change of the stop signal. All other settings provide a sin² - transition from operating speed to zero or vice versa within the preset time.

Cor-Divi:

This setting function is active in all operation modes. Setting range 1-9. This provides a digital attenuation of the phase correction signal that is produced, when the drive on mechanical grounds (deadband or backlash) cannot respond. In such a case, it is not desirable to make corrections immediately. The "Cor-Divi" provides a window for the drive "backlash", within which the controller produces no correction, and a division of the incremental error count.

Value 1 = No window, Reaction to 1 error increment, no division.

Value 2 = Window +/- 1 Encoder increment, division :2

Value 3 = Window +/- 3 Encoder increments, division :4

Value 4 = Window +/- 7 Encoder increments, division :8

Value 5 = Window +/- 15 Encoder increments, division :16 etc.

Please note that parameters **Alarm 1** and **Alarm 2** refer to the reduced phase error resulting from the division by your Cor-Divi setting. This must be considered when setting the alarm thresholds.

Phase Adj:

Only for index operation. Digital attenuation of the response upon marker pulse errors.

1 = full correction with each index check, i.e. 100%

2 = correction by several steps with 50% of the residual error

3 = correction by several steps with 33% of the residual error

4 = correction by several steps with 25% of the residual error

5 = correction by several steps with 20% of the residual error etc.

Clarification:

The setting depends on the dynamics of the drive and the maximum speed.

Example: If a marker pulse arrives every 20 msec but the drive cannot correct the largest error in 20msec, then it will lead to instability if the next correction is executed before the previous is completed. In such a case the phase correction percentage must be reduced.

Ind-Divi:

Only for index operation. This is a programmable index divider for the master marker pulses, permitting different numbers of marker pulses from the master and the slave. See Section 6. Range 1 - 99. For the same reason as clarified above, we also recommend to use the divider with marker pulse frequencies higher than 10Hz..

F1-Scal:

This factor allows scaling of the remote Fact1 entry to "user units" resp. to adapt the numeric value of Fact1 to the application.

It is **essential**, for all steps of setup, to programm **F1-Scal** to **10000** first in order to avoid confusions with factor calculations.

(Only with this value, the setting corresponds to the real operative Fact1)!

Once the setup procedure is terminated, set F1-Scal to the numeric value that later should correspond to an operative value of 1.0000 for Fact1. Example: if the operator desires to set 3.5000 instead of 1.0000, set F1-Scal to 35000. For all factor calculations, please be aware if you operate with a proportional or a reciprocal characteristics of Fact1!

Fac1-min, Fac1-max:

These are limitations of the setting range of Fact1 and out of range settings will be overwritten by the appropriate min or max value. With Fac1-min set to 0.9500 and Fac1-max set to 1.0500, the operator is limited to a +/- 5% variation of the speed ratio.

Ind-Wind:

This parameter sets a window, where the master and slave index pulses should be within during operation. It is possible to set the value in a range from 1 to 9999 encoder increments. It affects the output "Index o.k.", when master and slave index pulses are out of range.

Mast-MC:

Defines “Standstill” of the Master drive by a minimum master encoder frequency (Hz). The master motion output is high when the feedback frequency exceeds this setting and goes low when underpassed.

Ind Mode:

This register selects the index source (i. e. the cutting pulse and the print mark pulse). You are free to use either the TTL inputs on the encoder connectors, or the HTL inputs at the control IN / OUT port PI / PO.

Index Mode	Slave index source	Master index source
0	HTL, pin 8 on PI / PO	HTL, pin 20 on PI / PO
1	TTL index pins 6 and 7 at Slave input	HTL, pin 20 on PI / PO
2	HTL, pin 8 on PI / PO	TTL index pins 6 and 7 at Master input
3	TTL index pins 6 and 7 at Slave input	TTL index pins 6 and 7 at Master input

Fig.30

Max Corr:

With index applications it may be desirable that corrections of index errors are limited to a certain amount (i.e. to avoid damage of the material). Set this register to the maximum number of encoder increments that should be corrected in one correction in several steps with limited pitch. Set the register to 000 to receive full correction at a time.

SampTime:

Provides digital filtering of the feed forward signal generated from the master encoder. Range 0001 - 1000 msec. Normal setting **1 msec** recommended.

In applications where the master speed is very unsteady, settings like 10 or even 100 msec can be advantageous for smoother motion of the slave. Please note that higher setting results in lower response with changes of the master speed.

12. Setup Menu**Mode:**

There are 8 modes of operation as shown in Fig. 19. Setting range 1 - 8.

LV-Calculation:

This parameter determines the relationship between the factor settings and the resulting slave speed. Also it selects analogue or digital feed forward operation.

With settings 1 - 4, an analogue signal proportional to the master speed must be applied to pin 6 of the analogue connector.

Settings 5 - 8 are similar to 1 - 4, but the feed forward signal is generated by the internal f/V converter and pin 6 of the analogue connector must remain unconnected.

LV-Calc = 1 or 5:

The slave speed changes **proportionally** to the Factor 1 setting, i. e. doubles motor speed when changing Factor 1 from 1.0000 to 2.0000. This setting is suitable for the majority of all synchronising applications.

LV-Calc = 2 or 6:

The slave speed is **reciprocal** to the Factor 1 setting, i. e. halves the motor speed when changing Factor 1 from 1.0000 to 2.0000. This setting is suitable for rotating cutter applications (Factor 1 represents the length preset) and all other applications where the engineering units are reciprocal to the motor speed.

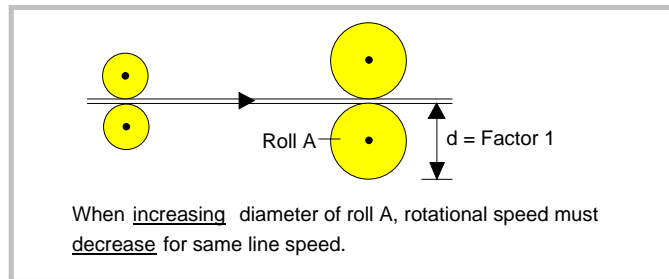

Fig. 31

LV-Calc = 3 or 7:

The slave speed changes **proportionally to Factor 1** and **reciprocally to Factor 2**. Suitable for various applications which need remote setting of both scaling factors.

LV-Calc = 4 or 8:

The slave reference voltage remains constant, independent of Factor 1 and Factor 2 settings.

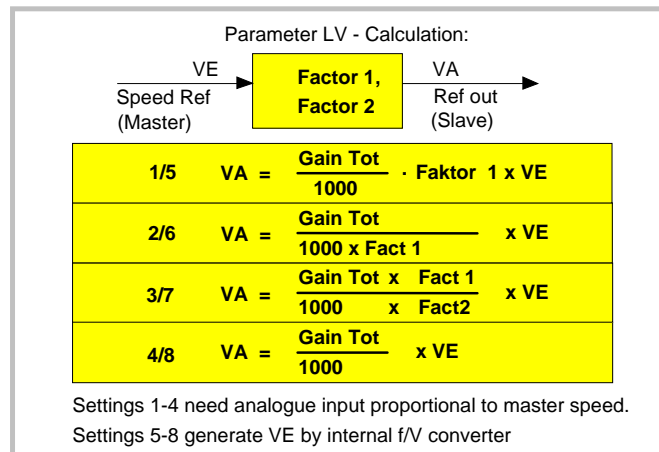

Fig. 32

Clarification When LV - Calc is set to 1, the output voltage will be equal to the input voltage with Fact 1 = 1.0000 and Gain Tot = 1000.

D-config:

Only with reversals of the master/slave rotation direction. See direction control inputs on page 19. As a definition of the drive types, the following table uses **4Q** for 4 quadrant drives, +/- 10V reference input, reversal by polarity of speed reference and **CONT** for switch reversal drive types, which always operate with a positive reference and the direction is selected by external contacts.

D - Config	Master	Slave
1	4 Q	4 Q
2	4 Q	Cont
3	Cont	4 Q
4	Cont	Cont

Fig. 33

PI-Form:

Selects the input code of the parallel interface (PI):

0 = data entry with BCD code (1-2-4-8)

1 = data entry with binary or hexadecimal code

Add-Cor:

Switches the internal summation of the analogue correction signal on/off.

0 = off, no correction added to the analogue output.

1 = on, correction superimposed on the slave reference.

Must always be set to 1 for normal operation.

Unit-Nr:

For serial operation only. Allows entry of a device address between 11 and 99. It is not allowed to use addresses containing a "0" (i. e. 20, 30, 40 etc.) as these are reserved for collective addressing of several units.

Baud-Rate: For serial operation only. The following transmission rates can be selected:

0	9600	Baud
1	4800	Baud
2	2400	Baud
3	1200	Baud
4	600	Baud
5	19200	Baud
6	38400	Baud

Fig. 34

Factory setting: 0

Ser-Form: For serial operation only. The following formats of serial data can be selected:

Ser-Form	Databits	Parity	Stopbits
0	7	Even	1
1	7	Even	2
2	7	Odd	1
3	7	Odd	2
4	7	None	1
5	7	None	2
6	8	Even	1
7	8	Odd	2
8	8	None	1
9	8	None	2

Fig. 35

Factory setting: 0

Bus-Add, Bus-Baud, Bus-Config, BusTxPar, BusRxPar:

Only relevant for units with option „field bus interface“ (CAN-Bus or PROFI-Bus DP). See supplementary instructions for further information.

Mast Dir:

Direction of phase of the master encoder. Settings can be changed from "0" to "1". When the master encoder is rotated "**forward**", the front LED's **go up**. If incorrect, change the A+B channels **or** this direction bit to get correct counting sense.

Slav Dir:

Direction of phase of the slave encoder. When the slave encoder is rotated "**forward**", the front LED's **go down**. If incorrect, change A+B channels **or** this direction bit to get correct counting sense.

Hint: The phase direction bits can also be easily set in the Testprog-Menu. When you select Master direction or Slave direction, the LCD display operates as an up/down counter. The LCD must always count up when you move the Master or the Slave forward. Counting sense can be inverted by pressing Key "A".

Off-Cor:

Digital setting of analogue offset on correction signal. Setting range +/- 99. Normal setting "0" *)

Gain-Cor:

Digital setting of gain control (proportional control) Range 0 - 9999. Setting to 9999 results in a response of 100 mV per error bit. Recommended setting: 30....300 (i. e. 0,3 mV....3mV per error bit).

Offs-Tot:

Digital setting of the offset on the slave speed reference output.
Range +/- 99. Normal setting "0" *)

Gain-Tot:

Digital setting of multiplication of analogue voltage signal. Range 0 - 400000.

*) **Remark:** BY 150 uses precision instrumental amplifiers which do not need an offset adjustment. In larger drive plants however, by balance currents between several devices, an external offset can build up, which can be compensated by the offset adjust. Also, offset settings different from zero may be used to compensate for deadbands which some inverter drives have with very low speed reference voltage.

13. Adjust Menu

There are only the parameters Gain-Cor and Gain-Tot accessible (the same as described above), but in this menu they can be changed continuously with the motors running. This allows easy adjustment of the analogue synchronisation and the intensity of correction while observing the LED bar graph and the drives. Keeping down key A continuously increments the values and key B decrements, while the LCD displays the current state. The PRG key stores the setting to the EEPROM and key C resets the LED bar graph to it's green centre position.

14. Testprg - Menu

This menu contains a couple of useful tests for the synchroniser itself and it's peripheral devices (encoders, remote lines etc.)

Mast-Dir: This is the same register as in the setup menu, but the LCD display operates as an up/down counter for the master encoder pulses, permitting full check of the encoder functions. When the encoder is rotated "**forward**", the counter counts **up**. If incorrect, press "A" to change the counting direction. Key "B" operates as a counter reset button. Key "PRG" automatically stores the direction in the Mast-Dir register.

Slave-Dir: Similar to Mast-Dir, but slave encoder. Counter must also count **up** with forward rotation.

Off-Cor: Similar to the setup menu, but continuous scroll up/down by keys "A" and "B" and 100x increased resolution (100 mV output correspond to 1 mV in reality) for better measuring.

Gain-Cor: Similar to the setup menu, but continuous scroll up/down by "A" and "B" and full scale correction output (1024 error bits are simulated).

Offs-Tot: Similar to setup menu, but scroll function with "A" and "B"

Gain-Tot: Similar to setup menu, but scroll function with "A" and "B"

LED+PO: Test for front LED`s and Control outputs PI/PO. Switches on and off all LED`s and outputs, one after the other.

Cont-In: Checks and displays the state of the PI/PO control inputs. The LCD display shows the inputs in hexadecimal code (0...9, a,b,c,d,e,f). Touching key "A" changes the code to "1 of 12" and the high state pin numbers of the connector appear in the display. In this code, only **one** pin can be displayed.

PI-IN: Displays the state of all data and select lines in a BCD or hexadecimal code. Suited best to check data transmission from a remote switch or a PLC.

Factory: Hidden registers, factory accessible only.

15. The LED Display

The 8 LED's mounted on front of the module indicate the instantaneous angular difference between the two drives. The display provides information for commissioning and fault monitoring, in a very simple form.

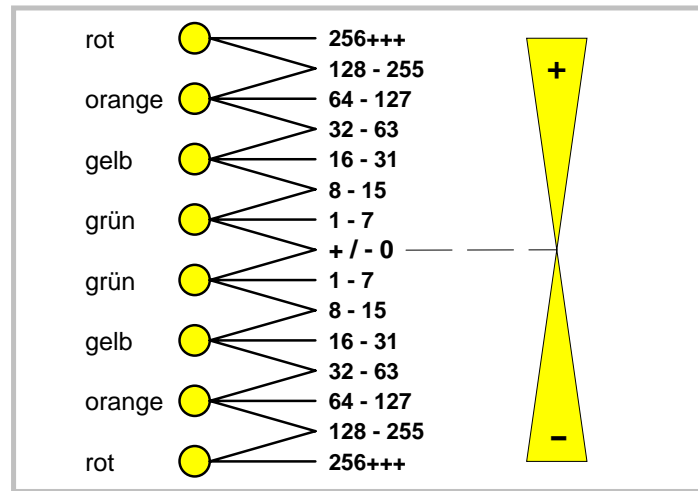

Fig. 36

When both green LED's in the centre are lit, the phase error is absolutely zero.

When either of the green LED's is lit alone, the error lies between 1 to 7 bits. When one green and one yellow LED is lit, the phase error lies between 8 to 15 bits, etc.

When the lights are up, this indicates positive correction (Master is ahead, increase Gain-Tot). When the lights are down, this indicates negative correction (Slave ahead, decrease Gain-Tot).

The above notes hold for positive reference giving forward rotation. Everything is reversed for negative reference giving forward rotation.

16. Analogue Signal Guide

The following block diagram shows the full internal treatment of the analogue line signal and the registers involved. Some signal inversions, under control of the direction inputs and the D-Config register, have been omitted for easier comprehension.

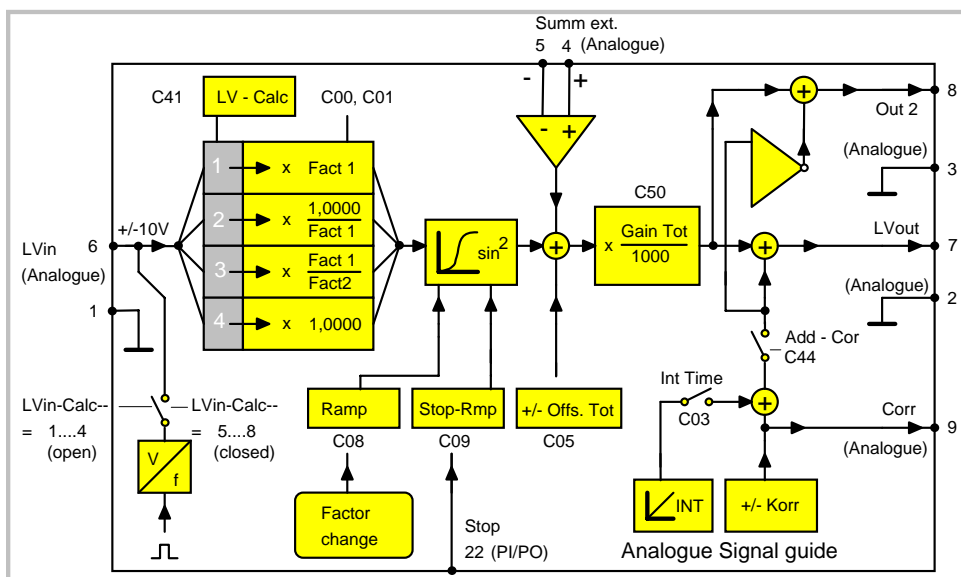

Fig. 37

17. Digital Signal Guide

The following block diagram refers to all essential impulse processing necessary to create the analogue correction signal. For easier comprehension, unimportant details have been omitted.

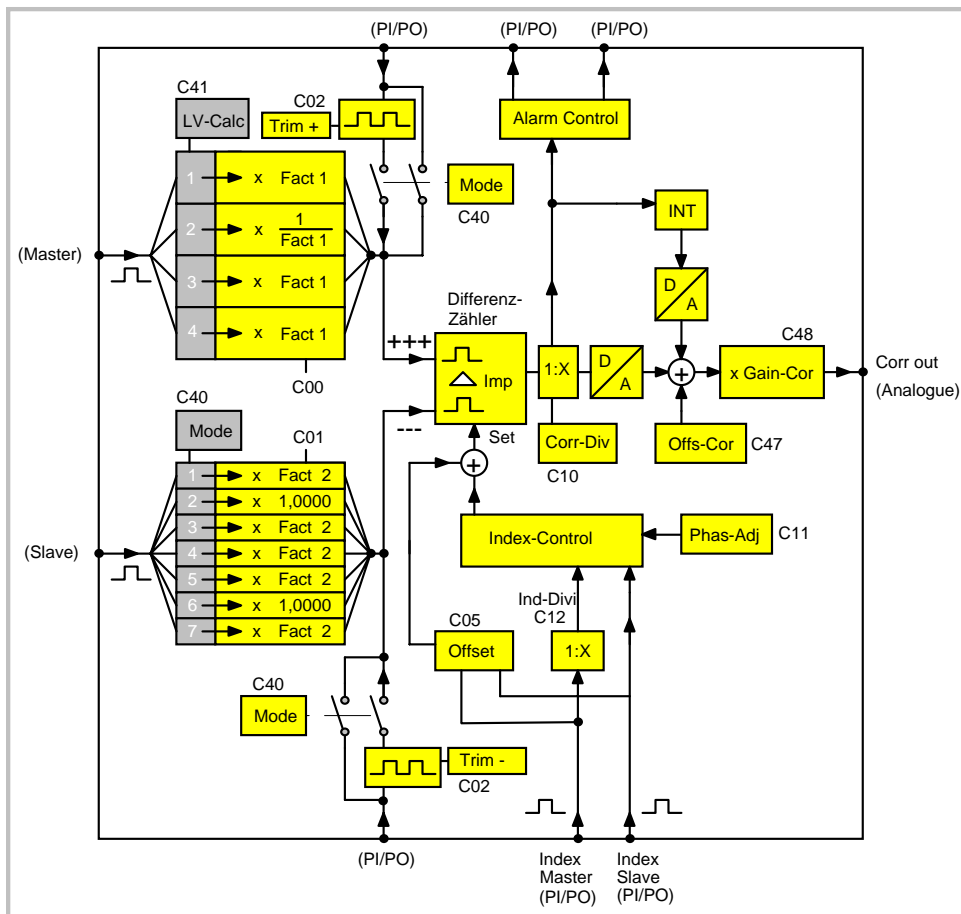

Fig. 3828

The total analogue correction output can be calculated as follows:

$$\text{Korr} = \frac{\Delta \text{ Imp}}{\text{Corr- Div}} \times \frac{\text{Gain-Cor} \times 10 \text{ mV}}{1024} \quad (\text{m V})$$

An analogue saturation comes up with 1024 error bits, but the counter itself will memorise and compensate for up to 32000 error bits.

18. Remarks about Drives, Encoders, Cables, Installation

- 18.1 The **drives** in use must be dimensioned correctly with respect to power and dynamics required. **The BY 150 can never provide synchronisation outside the physical limits of the drives.** Prior to connecting the master and the slave to the synchroniser, they must be adjusted for a proper stand-alone operation with no oscillation, by means of a remote speed reference voltage. The reference inputs must be potential free. The slave must be set to a maximum dynamic operation. You must set all internal ramps to zero or minimum. Where your slave drive allows to adjust the proportional gain, use the highest settings possible with regard to a stable operation.

Avoid ground loops, i. e. between the power supply source and the minus potential of the speed reference input which might be grounded also.

- 18.2** The resolution of the TTL-**encoders**, in principle, should be as high as possible, in order to keep the mechanical phase error as small as possible when the synchroniser "plays" a few encoder increments around the zero error position. However it would be nonsense to choose the number of ppr much higher than needed or reasonable. If, for example, a gear box with several 0.1 mm of clearance is installed, a 0.01 mm resolution of the encoder could cause stability problems, which needed to be removed by the "Corr-Div" error divider again.

The BY 150 loads each encoder channel with a current of 12 mA. For this reason, one encoder could be unable to supply the impulse inputs of several synchronisers at a time, as needed with some multi drive systems. In such applications, our impulse distributor type GV 150 must be used to feed several synchronisers from one encoder.

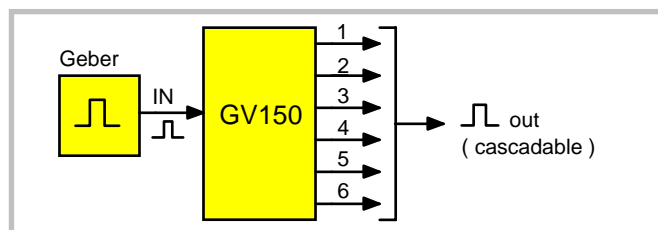

Fig. 39

Please note, that **not all types of cables** are suited to transmit frequencies as high as **300 kHz!** However, with proper installation and screening, the RS 422 lines provide perfect transmission even over long distances.

The **cross section** of encoder cables must be chosen with consideration of voltage drop on the line. The BY 150 provides a 5.5 V encoder supply and at the other end the encoder must at least receive it's minimum supply voltage! (See encoder specifications).

- 18.4 All cables should be installed separately from motor cables and other power lines!** Use normal filtering methods for all inductive equipment installed close to the synchroniser (i. e. RC filters for AC contactors and diodes for DC inductive circuits). Observe all standards and precautions usual for wiring and environment conditions with industrial electronic equipment.
- 18.5** If you need to switch electronic signals by relay contacts, it is **necessary** to use relays with **gold contacts**. For impulse or analogue switching, we recommend the use of our electronic matrix switch type GV 155.

19. Steps for Commissioning when using a PC and the OS3.2 software

This section describes, step by step how to set up the BY150 synchro controller with a PC. We recommend to use a PC because it makes everything much easier where you do not have a PC, please follow the subsequent steps by using the LCD and the keys for entry of data.

Make sure that the drives are properly adjusted to run the speeds needed for later synchronisation. When using analogue feed forward, the internal acceleration ramps of Master and Slave must be set to minimum. With digital feed forward, the Master may use internal ramps, but the Slave ramps must be set to zero or minimum.

Observe all remarks and hints given in this manual and the drive's manual. In case of any problems, a digital multimeter and an oscilloscope should be available.

- 19.1** Remove right hand side plate and adjust carefully DIL switch S1, as shown in section 4.
- 19.2** Verify that all connections are correct. Disconnect first all connectors from the front, except the power supply connector. Switch power on. After a short delay, both LED's on the front will begin to blink.
- 19.3** Connect your PC to the BY150 unit like shown previously.

19.4 Start the OS3.2 operator software.

You must see the following main screen now.

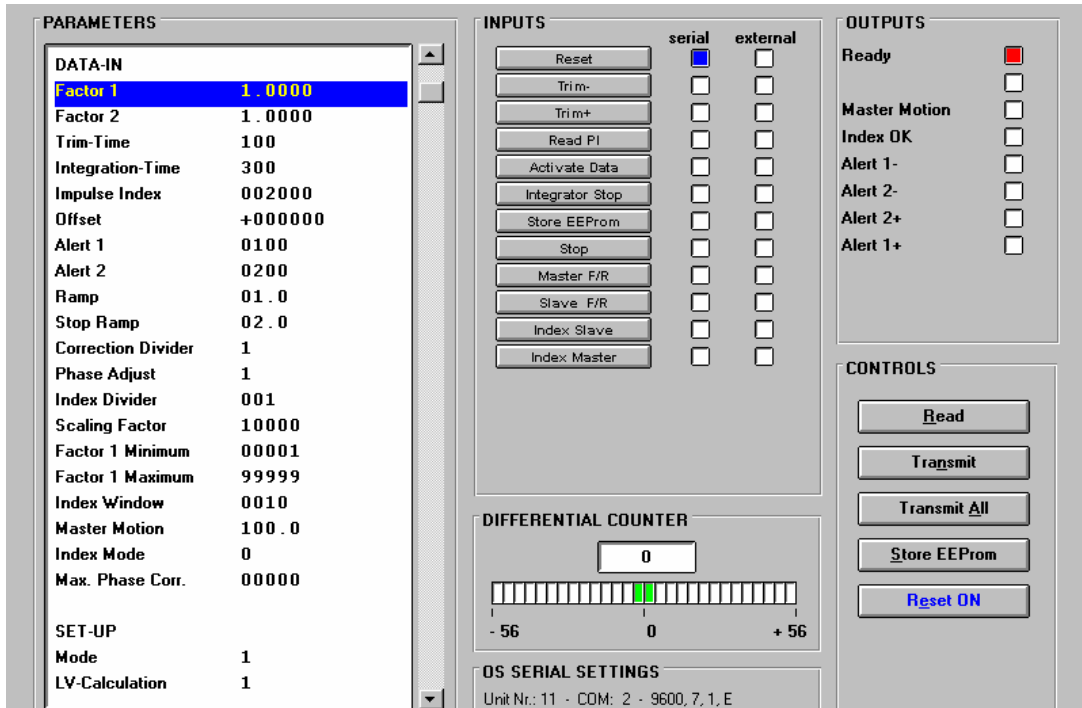

Where you find an empty mask with the indication "OFFLINE". click to the **Comms** menu and verify the serial settings.

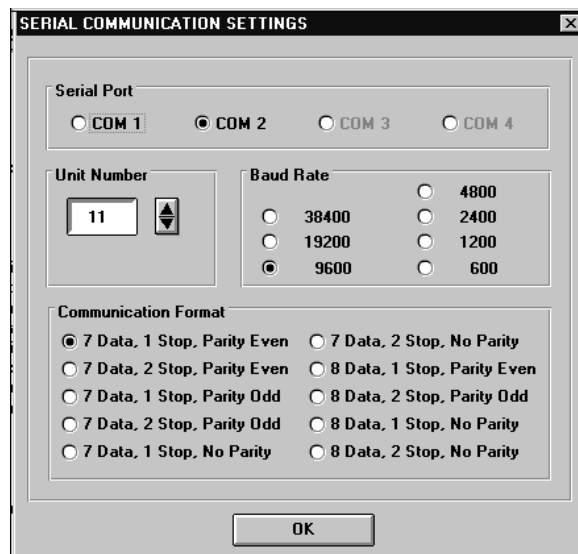

Ex factory, the BY150 is set like shown on the screen and you must set the COM number of your PC which you use for communication. Where you do not know the actual settings of your BY150 unit, you can use the **SCAN** function in the **Tools** menu to find out.

- 19.5 When serial communication is o.k., **enter all variables** according to your application. The following registers must be set to fixed values for the first steps of commissioning, like shown in table. (You can change these settings later when the first steps have been completed successfully.)

Integration Time	:	000
Correction Divider	:	1
F1 Scaling Factor	:	10000
Factor 1 Minimum	:	00001
Factor 1 Maximum	:	99999
Mode	:	1
LV- Calculation	:	a) 1 with analogue feed forward b) 5 when you use the internal f/V converter (digital feed forward)
Gain Correction	:	100
Gain Total	:	a) 1000 with analogue feed forward b) see table for digital feed forward

Fig. 40

With digital feed forward, the initial "Gain Total" setting depends on the master encoder frequency at maximum master speed.

fmax	Gain Total
1 kHz	250000
3 kHz	83000
10 kHz	25000
30 kHz	8300
100 kHz	2500

Fig. 41

Settings shown are approximate and values between can be interpolated. Some other settings are unknown and not important at this time (e.g. Master direction)

When you have entered all variables, click the **Transmit All** button and then the **Store EEPROM** key to transmit and store data to the BY150 synchroniser.

Remark: Where you find letters undersigned, you can get the same function also by keypad, pressing **ALT** and the corresponding key (ex. **ALT** + **S** = Store EEPROM).

19.6 It is recommendable to check the correct function of the external control signals you have connected to the unit. When you switch ON and OFF the remote signals, you can see the input state in the corresponding indicator box of the "external" column of the INPUTS field on your screen.

19.7 With the next step we need to find out the **direction bits** of Master and Slave. At this time we must be absolutely sure about the direction of rotation and our forward/reverse definition.

- Where we use analogue feed forward system (LV-Calculation = 1...4), the **forward** direction for both, Master and Slave, is the direction which the drives take when **positive speed reference** (o...+10V) is applied.
- Where we use digital feed forward system (LV-Calculation = 5...8), the polarity assignment is not important for the Master. But at any time, the **forward** definition for the Slave is again the direction it moves **with positive speed reference**.
- When in later operation no reversals are planned, set up your drives in a way that you **always use positive speed reference**. Where you later need to operate the drives in both directions, make sure you use always the "forward" direction for the following steps (like defined by a) and b).

The subsequent steps will fail upon non-observance!

Select the **Test** function of the **Tools** menu

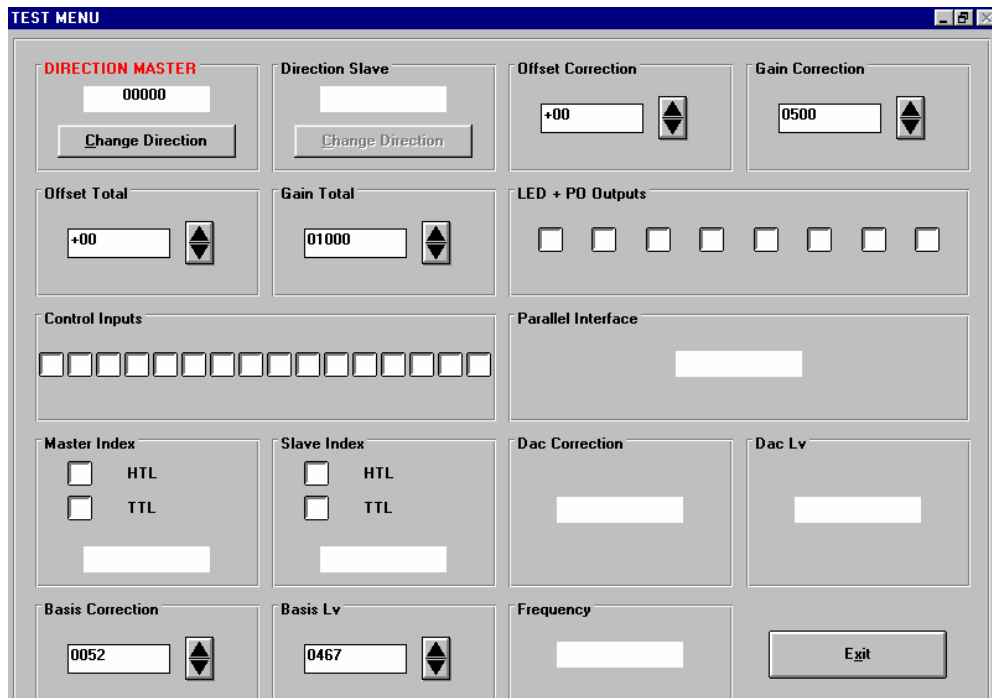

- Click to the "Master Direction" box and you will find an up/down counter for the master encoder. This counter must **count up** (increment) when you rotate the master encoder **forward**. If it counts down, click "Change direction" to reverse the counting sense. If it counts up, change over to the "Direction Slave" box.
- The "Direction Slave" counter again must **count up** when you rotate the Slave encoder **forward**. If necessary, change direction. If it counts up, click to any other box to exit the direction settings.

This procedure has automatically set our Master and Slave direction bits to either 0 or 1 according to need.

Hint: You can use the previous procedure also to check the proper function of your encoders and wiring. While you rotate the encoder forward by exactly one or several turns, we must find the ppr number (or multiple) in our display window. When we rotate back by the same amount, our counter must again have reached zero. Any other result would indicate a problem like wrong wiring of encoder channels or slip of the coupling or interference due to bad screening etc.

19.8 When you use the parallel interface (PI), click to the Parallel Interface box and verify that your parallel data appear correctly on the screen. You can easily detect wiring faults or transmission problems when the figures shown in the indicator box do not match the data transmit.

19.9 When, in final operation, we do not use one of the Index operation modes, we can **exit** the Test Menu now. Where **Index functions** will be needed later, click to the "Master Index" and the "Slave Index" boxes to execute the following tests:

- When you move the corresponding axis forward, you will find the number of encoder pulses between two index pulses in the display window. Where the index comes from the encoder itself, this is the ppr number of the encoder. Many times, when using external index pulses from a proximity, the accurate number of pulses between two markers is not exactly known and you can find it out by this test (see "N", "K" and "Factor1" in section 6. which is important for successful index operation!).

- When we move slow enough, we can also see the index pulses blinking in one of the indicator boxes (Upper = HTL-index, Lower = TTL-index).
- When we rotate to reverse direction, the display will not show our impulse number, but it's 16 bit complement which is "65536 - impulse number".

After performing the index tests, exit the test menu and get back to the main screen.

19.10 We must now adjust our **Gain Total** setting. This is to ensure the Slave drive receives the correct speed reference voltage for the speeds it should run.

Select the **Adjust** function of the **Tools** menu.

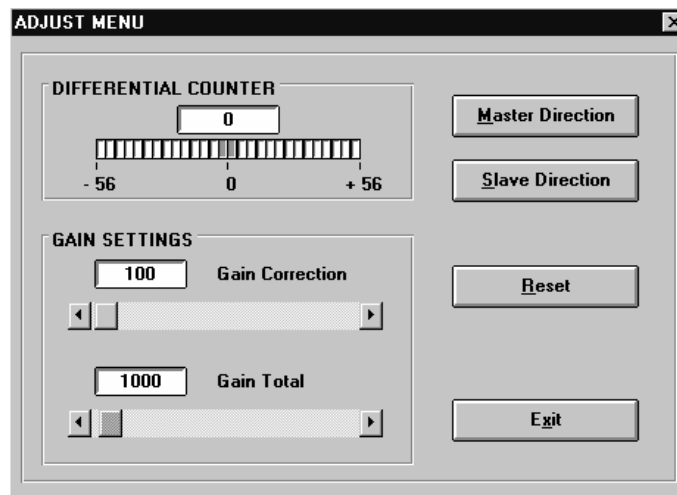

The subsequent procedure assumes our Gain Correction is set to 100 and you do not touch Gain correction before we have set Gain Total.

- Enable both, Master and Slave drive and run the Master **forward** at slow speed (e.g. 10-20% of max. speed). The Slave will follow the Master.
- Set the DIFFERENTIAL COUNTER to zero and the Colour bar graph to the green center by switching Reset to ON.
- Watch the colour bar while you switch Reset OFF. It will deviate to right or left while the DIFFERENTIAL COUNTER counts to positive or negative. Please note, with very wrong initial setting we can swap over the opposite side after some time. Then please observe only to where we deviate immediately after releasing RESET.
- When we deviate to right (positive), our Gain Total setting is too low and must be increased.
- When we deviate to left (negative), our Gain Total setting is too high and must be reduced.
- Find the Gain Total setting that keeps the DIFFERENTIAL COUNTER around zero and the colour bar around the green center zone.
- For rough adjusting, use the slide button in the Gain Total field. For fine tuning, use the ◀ ▶ keys.

19.11 When Gain Total is set to keep the bar around zero, we adjust **Gain Correction** now. The general rule is to increase the setting to values **as high as possible**, but still ensure stable operation. Typical settings are between 300 and 2000. Depending on drive, inertia and gearing you can get stability problems when Gain-Correction is too high (rough or noisy motion of the drive and visible oscillation of the bar graph and the differential counter). If so, reduce Gain Correction until we are stable again. When you have observed stability problems, you should also try to suddenly stop and restart the master and ensure the slave does not tend to oscillate after this action also.

To change the Gain Correction settings use again the slide button and the ◀ ▶ keys like with Gain-Total.

19.12 Change the speed between standstill and maximum speed, observe the differential counter and the colour bar and **optimise** the Gain settings if necessary. Exit the ADJUST MENU when you feel your settings are o.k. This will automatically store your settings to the EEprom of the BY150 synchroniser.

This concludes the general setup procedure which needs to be done with every application. At this time your drives operate in a closed loop digital synchronisation and the next section will show you some hints how you could still improve performance with some applications.

20. Hints for Final Operation

20.1 Integrator

When, for stability reasons, you needed to keep your "Gain Correction" value low, any important non linearity in your drive system could cause changing phase errors* with changing speed (e.g. colour bar deviates to down at low speed, stays in center at medium speed and deviates to up at maximum, speed).

* Please note that a deviation of the colour bar does not indicate a speed error at all, unless the differential counter shows figures outside a +/- 1024 error increment range. Inside this range, the speed always is error-free and deviations only refer to the constant number of encoder increments that the Master leads or lags the Slave position.

Where your differential counter remains in an acceptable range around zero (e.g. -5....0....+5) at any speed, there is no need to use the Integrator and you can leave the "Integration Time" at 000.

Where you feel your phase accuracy should be better, set Integration Time to 50....40....30 20....10 or even lower. The Integrator will move the phase error always into a +/- 6 increments error window and the lower the setting, the faster the speed of compensation. Too low settings (= too high integration speeds) can result in oscillation, depending on individual inertia/friction/dynamic conditions of your system.

With Index operation, the Integrator is automatically switched off, because the marker pulses will compensate for phase errors.

20.2 Correction Divider

Where you find your colour bar oscillates quickly around zero over several fields, this indicates your encoder resolution is high with respect to mechanical clearance and backlash. Set the correction divider to 2 or 3 to get more stable operation.

20.3 Offset voltage

Some low cost AC inverter drives have a deadband around zero. e.g. they would not respond to small speed references like 50mV. This can cause the slave to lag the Master with very low speed. You are free to use the Offset Correction register and set it to a negative value like ""-50". This will result in a small positive output voltage like +50mV at standstill and the drive is kept at the threshold of it's deadband from where it can break off immediately.

20.4 Other settings

Up to now, we have operated in mode 1 with a couple of initial settings, in order to make commissioning easier. You are free now to set all variables to their final values, like required for your application.

20.5 It can be useful to observe the performance of synchronising by the oscilloscope function, which you can find in the **Tools** menu. You can record all the variables and registers by entering their serial access codes.

The following supplementary codes are available for readout and record:

:1	Synchronising error (Differential Counter)
:7	Integration register
:6	Index error: Difference between actual and desired position of the slave-index. Unit: slave encoder increments (register is only in use when index operation is activated).
:9	actual Master speed (1Bit = 5 Hz of master encoder frequency)

Fig 42

The following example shows the error register (channel 1) and the line speed (channel 2) while we accelerate the drives, an the peak shows how the unit corrected the position after an index check.

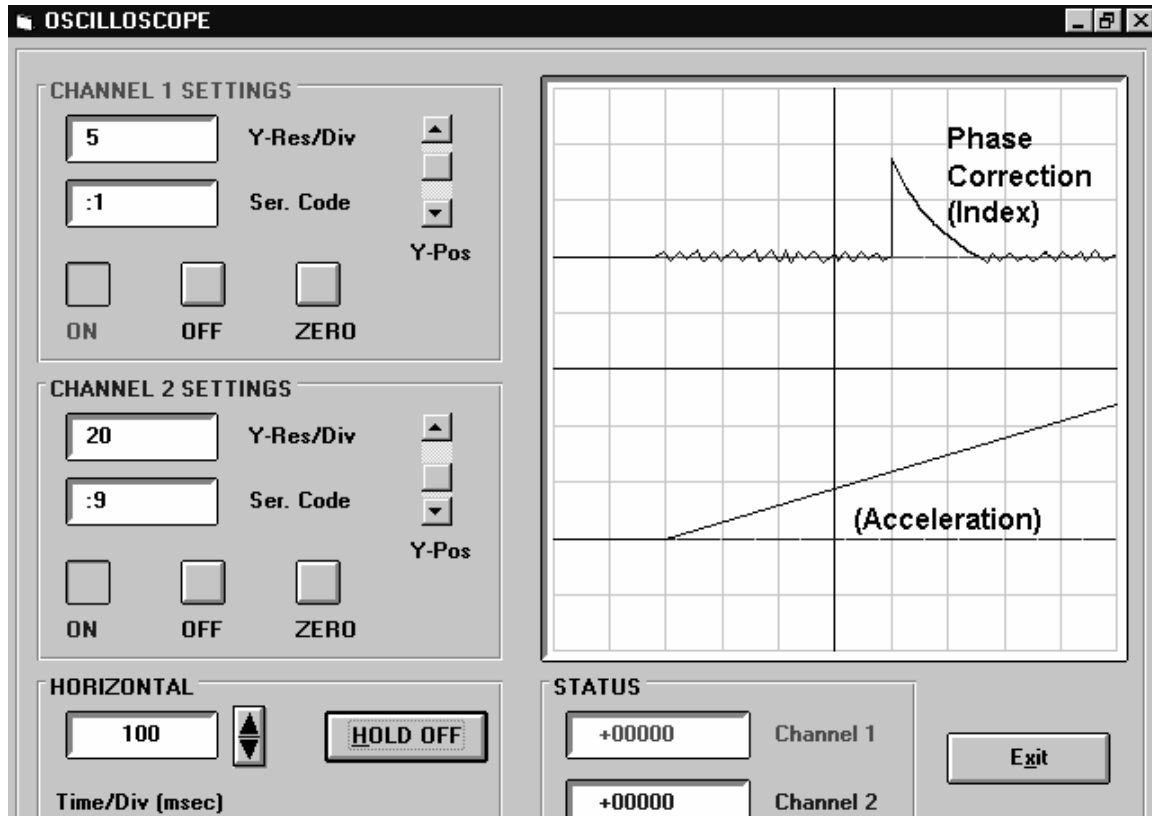

21. Serial Codes

Beside the serial access codes shown in this manual, the subsequent codes are available to execute the same commands that can be activated by the hardware inputs also:

Ser. Code	Bit of control word (C86)	Function	Type
55	14	Slave F/R	S
56	4	Read PI	D
57	2	Integrator Stop	S
58	0	Stop	S
59	15	Master F/R	S
60	7	Reset	S
61	13	Index Slave	S
62	12	Index Master	S
65	6	Trim -	S
66	5	Trim +	S
67	3	Activate Data	D
68	1	Store EEPROM	D

S = Static command, must be set to 1 to activate command and must be reset to 0 to deactivate command.
D = Dynamic command, must be set to 1 to activate command. Is automatically reset to 0 after execution.

Fig 43

All commands can be activated either by its serial access code or by setting the corresponding bit of the **control word (Ser. Access code 86)**.

Please note that all serial commands are logical ORed to hardware commands (control inputs) and hence a command is ON whenever set by serial command or hardware input or both at a time.

The state of the control outputs can be read out by the **status word (Ser. Access code 85)** via serial interface. Bit 7, 6, 5, ..., 1, 0 of the status word correspond to control outputs PI/PO pin 5, 17, 4, 16, 3, 15, 2, 14.

For more details please refer to the manual of the Drivcom protocol which is available on request.

22. General Master Reset and Erase of EEPROM

The unit carefully checks all entry data for validity and correctness within their permitted numeric range. If, as an extreme exception, invalid data should intrude into the register range, bad function or even a full hang-up could be the result. If this should ever happen

- push the Reset button on the unit's front (accessible by a small screw driver only)
or
- power down the unit and power up again after a few seconds.

Both measures result in a complete reconfiguration of all ports and registers. **RAM and buffer data** will be **lost** and the unit restores all data from the EEPROM.

If, however, invalid data should have penetrated to the EEPROM, even the previous steps will not help. In this case:

- switch off the unit
- set the slide switch PRG/RUN to the PRG position
- keep key A down while powering on the unit and keep it down for at least another 5 sec.

This will clear up all the EEPROM to its minimum values, and all registers need to be setup once more.

Above steps represent an emergency procedure that you will never have to apply under regular conditions. In an extreme case however (i. e. lightning-strike in the factory etc.) they could help to get the unit working again.

Please note that you must always use the EEPROM Erase Procedure when you have changed the processor for reasons of firmware upgrade !

23. The BY 106-X Remote Thumbwheel Switch

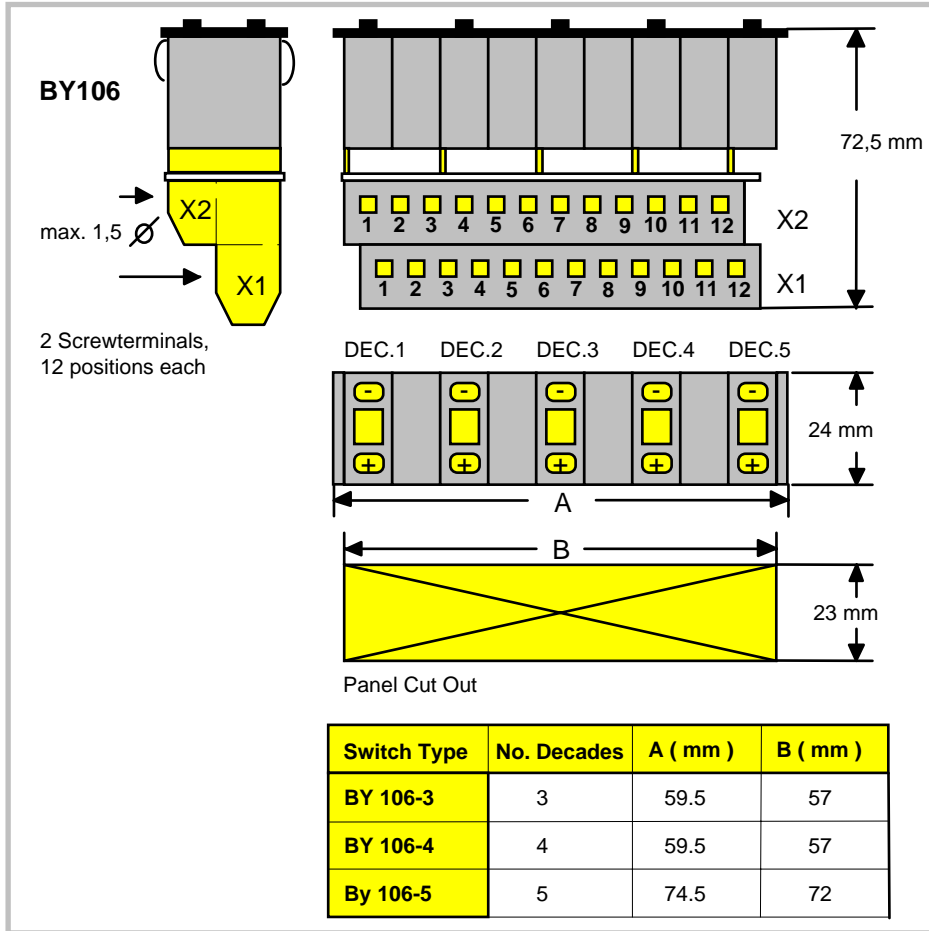

Fig.44

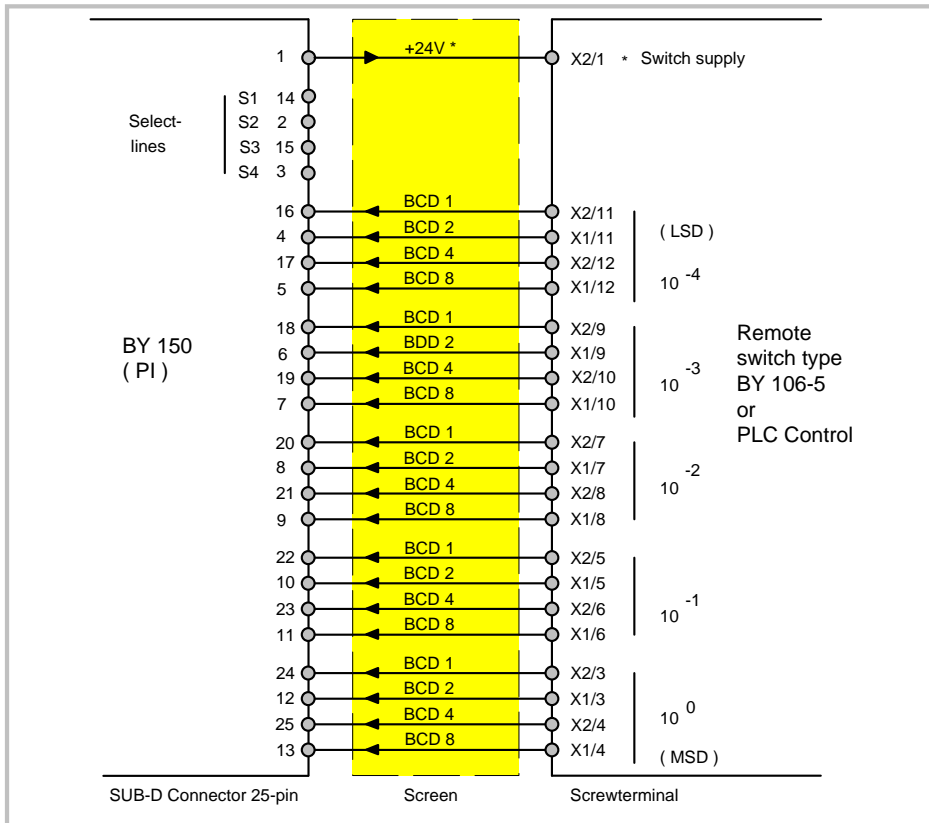
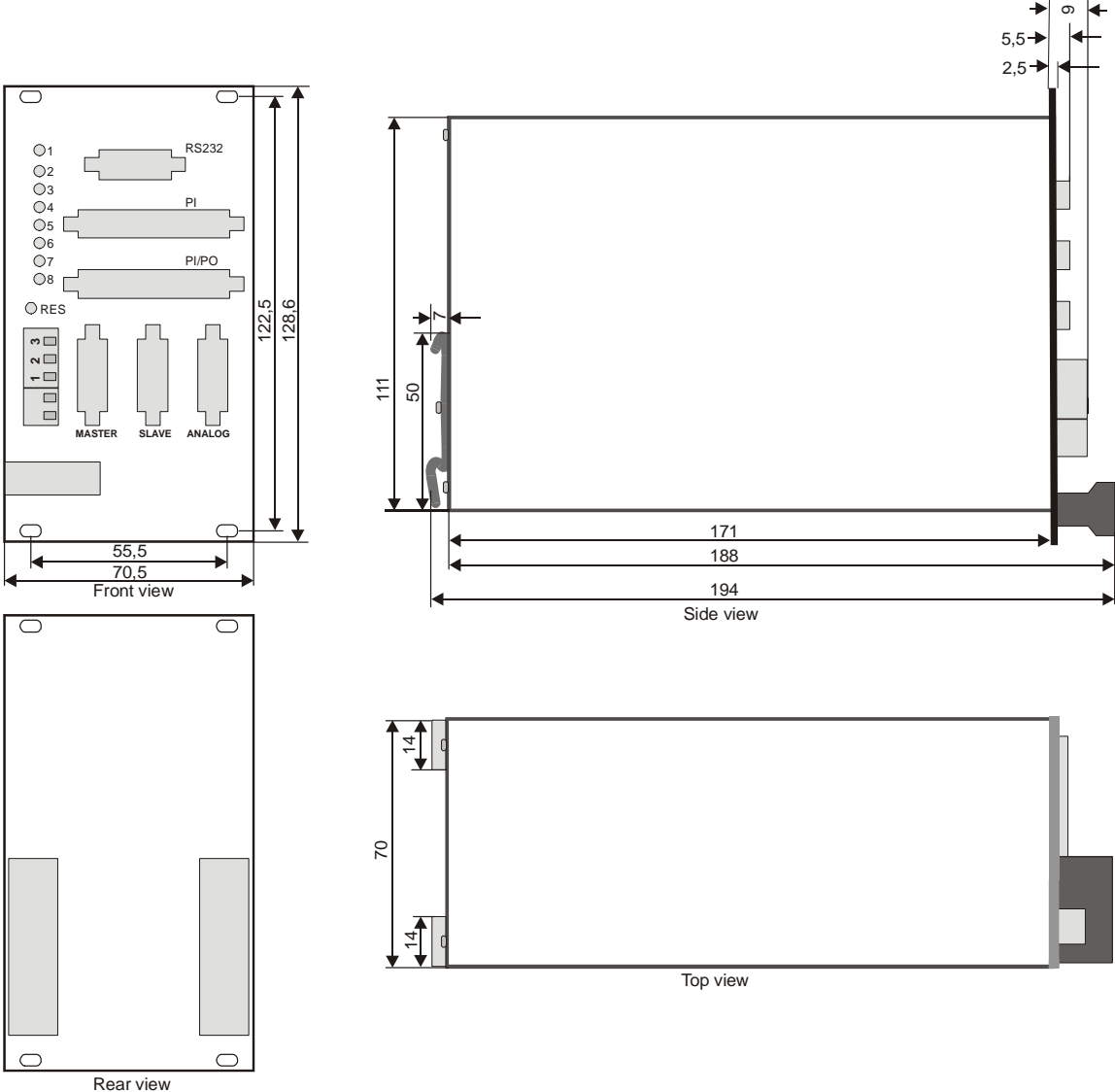

Fig. 45

24. Dimensions and Specification



Power supply	: 18...30 V un stabilised
Consumption	: approx. 300 mA (plus 25% of the encoder supply currents, if internal encoder supply used)
Encoder Supply	: Aux. voltage 5,5 V, max. 500 mA installed
Processor	: H8/532 with 20 MHz clock frequency
PCB and Technology	: SMD, Multiplayer PCB`s, High speed logic 74 HCT
Encoder Inputs	: Two A, A', B, B', Z, Z' (5 V TTL opto-isolated) Low < 0.8 V, High > 3.0 V (4.0 V with differential input signals)
Other Inputs	: 1 parallel port PI (24 lines) 1 control port (12 lines) all PNP with 10 - 30 V level.
Serial link	: RS 232 and RS485, CAN optional, Profibus u. d.
Absolute max. frequency	: 325 kHz
Response time	: approx. 100 µsec
Analogue In/Out	: 3 inputs +/- 10 V (Ri = 100 kOhms) 3 outputs +/- 10 V (Imax = 5 mA) Resolution: 12 Bit (= 4096 steps)
Analogue Correction	: 10 Bit = 1024 error increments
Error memory	: 32 000 error increments
Control Outputs	: 8 transistor outputs (opto-coupler 30V/30 mA max)
Speed error	: +/- 0,00 (absolute)
Operating temperature	: 0...45 °C
Dimensions	: see drawing
Weight	: Approx. 850 g

25. History

Version	Name	Date:	Page:	Changes / Supplements:
BY15014	TJ	Sept. 03	39	Serial access to control word and status word
N			42	Encoder inputs levels and max. frequency

Parameter List

Parameter	Dimension	Format	Serial Code	Minimum	Maximum	Default
Fact1	-	x.xxxx	C00	0.0001	9.9999	1.0000
Fact2	-	x.xxxx	C01	0.0001	9.9999	1.0000
Trimm	Program Cycles	xxx	C02	1	999	100
Int-Time	Program Cycles	xxx	C03	0	999	0
Imp-Ind	Slave Impulses	xxxxxx	C04	1	999999	2000
Offset	Slave Impulses	+xxxxxx	C05	-999999	+999999	0
Alarm 1	Slave Impulses	xxxx	C06	0	9999	100
Alarm 2	Slave Impulses	xxxx	C07	0	9999	200
Ramp	sec.	xx.x	C08	00.0	99.9	00.0
Stop-Rmp	sec.	xx.x	C09	00.0	99.9	00.0
Cor-Divi	-	x	C10	1	9	1
Phaseadj	-	x	C11	1	9	1
Ind-Divi	-	xxx	C12	1	255	1
F1 Scal	-	x.xxxx	C13	0.0001	9.9999	10000
Fac1-min	-	x.xxxx	C14	0.0000	9.9999	0.0001
Fac1-max	-	x.xxxx	C15	0.0000	9.9999	9.9999
Ind-Wind	Slave Impulses	xxxx	C16	0	9999	10
Mast-MC	Hz	xxx.x	C17	000.1	499.9	100.0
Ind-Mode	-	x	C18	0	3	0
Max Corr	Slave Impulses	xxxxx	C19	0	65535	0
Samp Time	msec.	xxxx	C20	1	1000	1

Parameter	Dimension	Format	Serial Code	Minimum	Maximum	Default
Mode	-	x	C40	1	8	1
LV-Calc	-	x	C41	1	8	1
D-Config	-	x	C42	1	4	1
PI-Form	-	x	C43	0	1	0
Add-cor	-	x	C44	0	1	1
Unit-Nr.	-	xx	C90	11	99	11
Baud-Rat	-	x	C91	0	6	0
Ser Form	-	x	C92	0	9	0
Bus-Add	-	xxx	C93	1	127	1
Bus-Baud	-	x	C94	0	7	1
Bus-config	-	xxx	C95	0	255	1
BusTxPar	-	xxx	C96	0	255	0
BusRxPar	-	xxx	C97	0	255	0
Mast-Dir	-	x	C45	0	1	0
Slav-Dir	-	x	C46	0	1	0
Offs.Cor	-	+xx	C47	-99	+99	0
Gain-Cor	-	xxxx	C48	0000	9999	100
Offs-Tot	-	+xx	C49	-99	+99	0
Gain-Tot	-	xxxxxx	C50	0	400000	1000

List of Commands

Command	Serial Code	Bit pattern (hex) of control word C86	Input
Reset	60	0x0080	PI/PO Pin 13
Trim-	65	0x0040	PI/PO Pin 25
Trim+	66	0x0020	PI/PO Pin 12
Read PI	56	0x0010	PI/PO Pin 24
Activate Data	67	0x0008	PI/PO Pin 11
Integrator Stop	57	0x0004	PI/PO Pin 23
Store EEPROM	68	0x0002	PI/PO Pin 10
Stop	58	0x0001	PI/PO Pin 22
Master V/R	59	0x8000	PI/PO Pin 9
Slave V/R	55	0x4000	PI/PO Pin 21
Index Slave	61	0x2000	PI/PO Pin 8
Index Master	62	0x1000	PI/PO Pin 20

List of Actual Values

Serial Code	Description	Scaling
:0		
:1	Diff. Count (divided)	Increments (scaled)
:2	LV value	Increments of DAC
:3		
:4		
:5		
:6	Phase error	Slave Increments
:7	Phase integrator	
:8	Phase counter	Master Increments
:9	Master frequency	5 Hz
;0		
;1	CAN Status byte	
;2		
;3		
;4		
;5		
;6		
;7	Diff. counter (undivided)	
;8	Dual-Port-RAM, Status byte	
;9		

The values shown above are available for readout and for display by means of the scope function.