

**Series
TM**

**Absolute mechanic multiturn shaft encoder
24bit (ø90mm)**

Utilise a very modern technology; a particular code-reading method allows to eliminate every mechanic action of gears to assure a real absolute value of the recording. Furthermore it permits to choose the code and the increment direction having in basic configuration as gray code as binary code as up/down discriminate.

Mechanics Data

Cover:	Lacquered aluminium
Body:	Aluminium
Solid shaft:	Stainless steel
Bearings:	2, ballraces
Weight:	Approx.800gr.
Protection:	IP65
Rpm:	3000 Max
Torque:	5Ncm
Inertia:	270gcm ²
Shaft loading:	Axial 50N - Radial 50N



Dimension in mm.

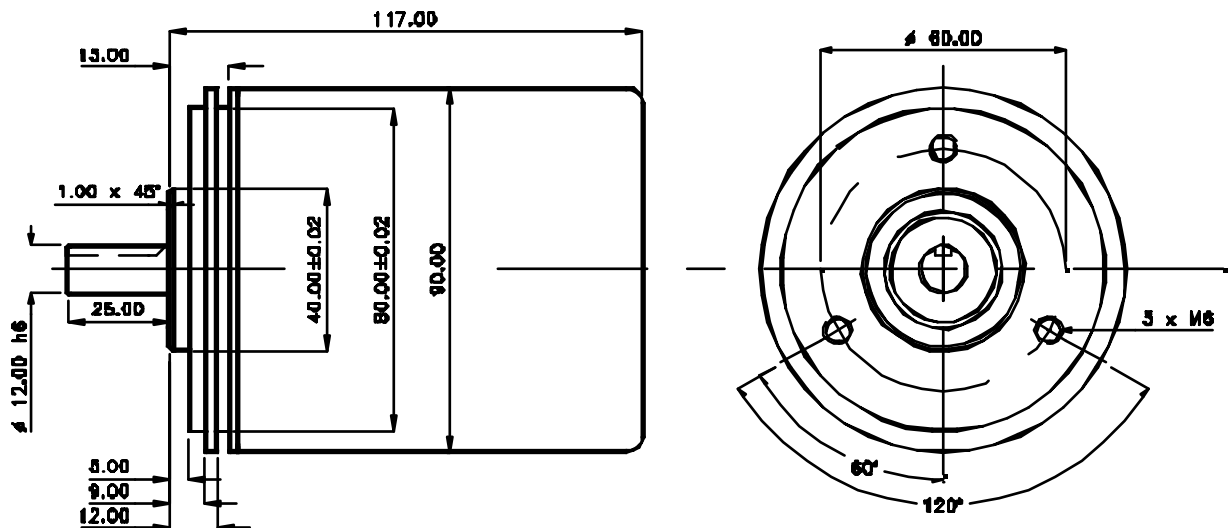

Series TM

Electronics Data

Power supply: from 5 to 24V depends on the electronics circuit
 Current consumption: 150/300mA depends on the electronics circuit
 Permissible load: 20mA
 Frequency: 10KHz (standard in LSB)
 Protections: Against short circuit, reversal polarity
 Operating Temp.: 0/+60°C

Ordering code

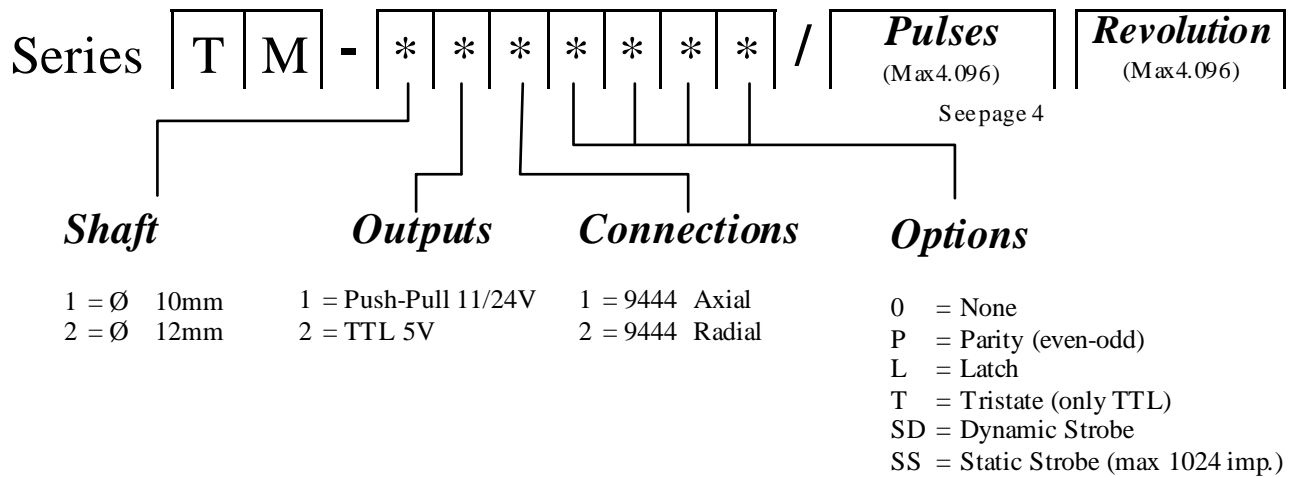

Connector 9444	0 Volt	+ Volt	0 2	1 2	2 2	3 2	4 2	5 2	6 2	7 2	8 2	9 2	10 2
	P1	P2	P3	P4	P5	P6	P7	P8	P9	P10	P11	P12	P13
	11 2	12 2	13 2	14 2	15 2	16 2	17 2	18 2	19 2	20 2	21 2	22 2	23 2
	P14	P15	P16	P17	P18	P19	P20	P21	P22	P23	P24	P25	P26
	GRAY BINARY		UP DOWN		PARITY EVEN		PARITY ODD		LATCH		TRI-STATE		STROBE
	P38		P39		P40		P41		P42		P43		P44

Encoder inputs are internally connected to logical "ONE".

Standard configuration:

- Output code GRAY
- increase (UP) clockwise
- High impedance output (TRI-STATE active)
- LATCH deactivate

Connecting input to logical "ZERO" the configuration change:

- Output code binary ;
- Decrease (UP) anticlockwise;
- True output (TRI-STATE) deactivate;
- LATCH active