

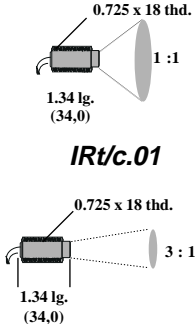





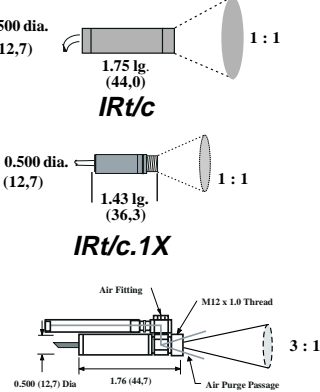

Pre-Calibrated Models

Factory-calibrated to match thermocouple signals over selected temperature ranges • For non-metal surfaces (coated metals are acceptable) • For use with “thermocouple input” controllers, PLCs, transmitters, and recorders available worldwide • All sensors exceed NEMA 4, 4X; IP65, 67; and are intrinsically safe.

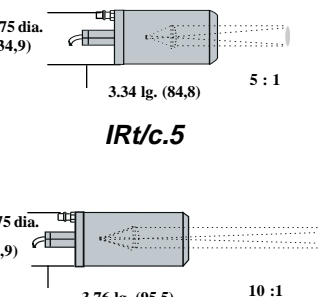
 <p>IRt/c.01</p> <p>IRt/c.03</p>	<h2 style="text-align: center;">Light-duty Models</h2> <p>Excellent for light-duty OEM equipment • High-strength ABS housing with mounting/lock nuts • Extension grade thermocouple wire with PVC jacket, unshielded • Rated for up to 160 F(70 C) ambient. • Small size allows easy design into existing OEM products • Target temperatures from -50 to 550F (-45 to 290C)</p>	
---	---	---

 <p>IRt/c</p> <p>IRt/c.1X</p> <p>IRt/c.3X</p>	<h2 style="text-align: center;">Stainless Steel Models</h2> <p>Rated for up to 212 F (100 C) ambient • Cooling jackets available for up ambients to 1000 F (540 C) • Tiny sizes allow easy installation in tight spaces • Twisted shielded base thermocouple wire, Teflon sheathed, rated to 392 F (200 C) • IRt/c.1X and .3X include threaded nose, lock-nuts, and mounting bracket • IRt/c.3X includes very high efficiency air-purge for dusty, misty, or dirty environs • Target temperatures from -50 to 1200F (-45 to 650C)</p>	
--	---	--

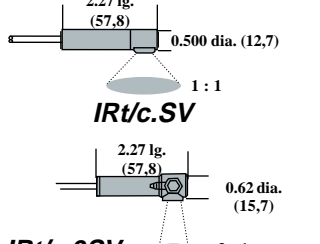
 <p>IRt/c.5</p> <p>IRt/c.10</p>	<h2 style="text-align: center;">Stainless Steel, Lensed Models</h2> <p>5:1 and 10:1 fields of view • Ideal for use at longer distances • Twisted shielded base thermocouple wire, Teflon sheathed, rated to 392 F (200 C) • Rated for up to 212 F(100 C) ambient • Built-in air purging/air cooling to 500 F(260 C) • Target temperatures from -50 to 1200F (-45 to 650C)</p>	
--	---	---

 <p>IRt/c.SV</p> <p>IRt/c.3SV</p>	<h2 style="text-align: center;">Stainless Steel “Side View” Models</h2> <p>Easily mounted in narrow spaces • Rated for up to 212 F(100 C) ambient • Twisted shielded base thermocouple wire, Teflon sheathed, rated to 392 F (200 C) • IRt/c.3SV includes built-in air purge for dusty, misty or dirty environs • Target temperatures from -50 to 1200F (-45 to 650C)</p>	
--	---	---

Signal Output	Thermocouple type J,K,E,T over temperature range specified (IRt/c.10, Type K only)
Power requirements	None
Cold Junction Compensation	By measuring instrument, as with conventional thermocouples
Emissivity	0.9, for non-metal surfaces
Repeatability	0.01°C
Ambient Temperature Coefficient	0.02% of reading/°F (0.04% /°C) (See Tech Note #90)
Response Time Constant	0.1 seconds approximately
Resolution	0.0001°C approximately
Spectral Response	6.5 to 14 microns
Output Cable	Twisted shielded pair of base thermocouple material (J,K,etc.), 3 ft (.9 m) std length, Teflon sheathed rated to 392°F (200°C) continuous service. (Except IRt/c.01 and IRt/c.03)

Selecting a Pre-Calibrated IRt/c

Ordering information: (Model) - (Thermocouple Type) - (Pre-Calibrated Temperature Range)

1. Select IRt/c(*) model. Example: IRt/c.3X
2. Select the thermocouple type (**) desired (J, K, etc.), add it to the model name.
Example: IRt/c.3X-K
3. Select the target temperature range. For example, to control a lamination process at 200 F (93 C), look at the following target temperature table for 200 F (93 C). Note the black area in the table indicates the "180F/90C" pre-calibrated range. Add this to complete your selection.

Example: IRt/c.3X - K - 180F/90C.

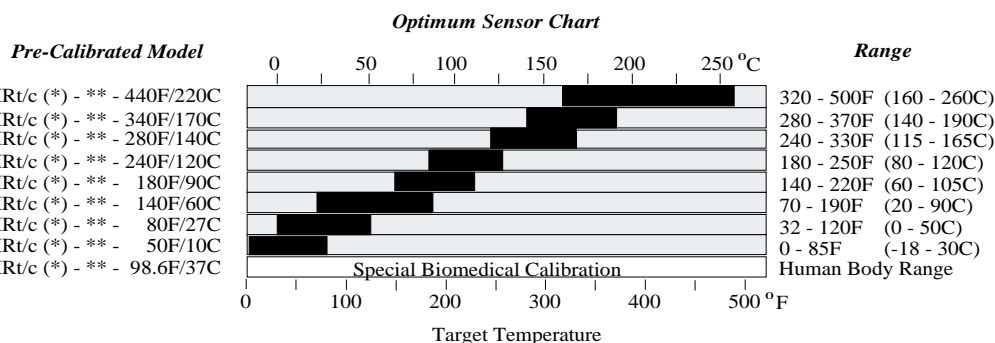

Additional note: The above table indicates the temperature ranges where the IRt/c's match standard thermocouple signals. This allows for highly accurate measurement and control in the ranges selected. IRt/c's require no power supply and can be connected directly to thermocouple inputs of controllers, PLC's, transmitters, and other t/c devices.

In addition, all IRt/c sensors are useable over the entire specified target temperature range for each sensor. Signal output tables and polynomials are available from Exergen.

Pre-Calibrated Models

ACCURACY

IRt/c's are pre-calibrated at the factory for typical target material emissive properties, but actual emissivities may differ. The accuracies specified assume that the precalibrated value is correct for your installation, or that the single point set up of Tech Note #1 has been performed to reduce the error to zero at the calibration point (which is normally the set point for a temperature control system).

1. Using Non-Programmable Thermocouple Interface Devices

Standard non-programmable thermocouple input devices deliver a high level of accuracy and repeatability with IRt/c's for most temperature measurement and control of factory automation, process control and OEM machinery. For example, if an IRt/c is calibrated to measure and control a non-metal target at 200°F (90°C) set point, the error will be $\pm 0\%$ or $\pm 0.02^\circ\text{F}$ (0.01°C) at the set point. As the target temperature varies from the original set point temperature, the error increases slightly according to the Accuracy Table (below). For example, if the interface device is set for 0% error at 200°F (90°C), then at the extremes of the temperature range of 190°F to 210°F (87°C to 99°C), the error would be $\pm 0.4\%$ or 1°F (0.6°C). This gradual error is caused by a difference in linearity between the output of the IRt/c compared to standard thermocouples. For detailed explanation, consult Tech Note #89.

2. Using Programmable Thermocouple Interface Devices, OEM, PLC, Computers

With programmable controllers, microprocessors, PLC, or computer interface, the error can be reduced to a small value even over a very wide temperature range. As shown in the Accuracy Table, IRt/c's produce high accuracies over a wide temperature range when the application requires it. For programming, contact Exergen for output signal tables.

Accuracy Table

Target Temperature Variation	Non-Programmable Thermocouple Interface Error* (greater of)	Programmable Thermocouple Interface
0°F (0°C)	0% or 0.02°F (0.01°C)	0% or 0.02°F (0.01°C)
±5°F (± 3°C)	± 0.2% or 0.5°F (0.3°C)	0% or 0.02°F (0.01°C)
±10°F (± 6°C)	± 0.4% or 1.0°F (0.6°C)	± 0.1% or 0.3°F (0.2°C)
±20°F (± 12°C)	± 1% or 2°F (1°C)	± 0.2% or 0.5°F (0.3°C)
±40°F (± 24°C)	± 2% or 4°F (2°C)	± 0.3% or 0.8°F (0.5°C)
±75°F (± 42°C)	± 5% or 8°F (5°C) approx.	± 0.5% or 1.2°F (0.3°C)
±180°F (± 100°C)	> 5% or 8°F (5°C)	± 1% or 2°F (1°C)
±540°F (±300°C) or full range	> 5% or 8°F (5°C)	± 2% or 4°F (2°C)

*Percent is of reading. For wide target temperature variations, target emissivity variations may cause greater errors. Multipoint calibration is recommended in such cases, and can reduce errors to less than 0.1%.

3. Repeatability Error is < 0.01°C (0.02°F)

Repeatability error, defined as the ability of the IRt/c to reproduce a reading under the identical conditions, is extraordinarily small. There are no active electronics to shift, and no source of spurious signals until the limit of resolution is reached, which is 0.0001°C, due to Johnson noise.

4. Interchangeability Error is ± 1% or 0.5 °C (1 °F)

Interchangeability error, defined as the difference in reading between any two IRt/c's of the same model making identical measurements, is of particular importance to users of multiple IRt/c's such as OEM's, or when an IRt/c must be replaced. The unit-to-unit consistency of IRt/c's permits the same calibration settings to be used for all subsequent installations for the same target material and temperatures. Interchangeability specification applies only to the signal generated by the IRt/c in its precalibrated range.

Adjustable IRt/c Models

These models allow users to calibrate the IRt/c sensors to match a thermocouple output in whatever temperature range desired. For example: if the requirement is to measure and control a non-metal target in the 1000 F to 1100 F (540 C to 590 C) range, an IRt/c.10A-K-HiE sensor can be selected. It is then installed and calibrated, in place, to generate a type K signal for that temperature range.

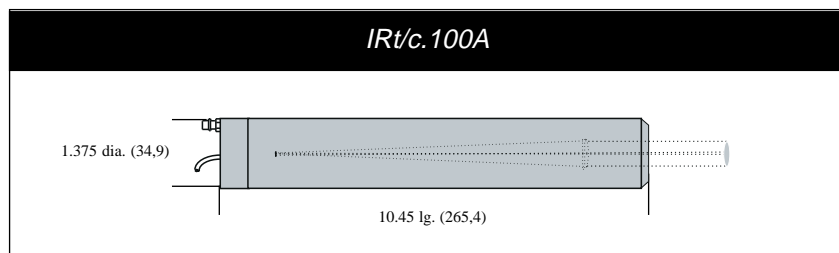
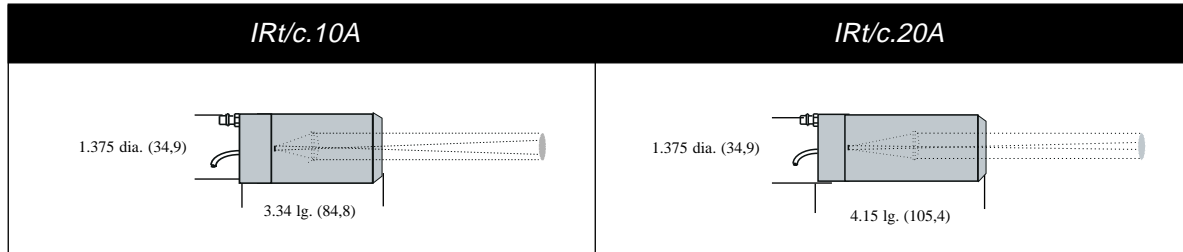

Approximate scale 1:5 dimensions in inches (mm).

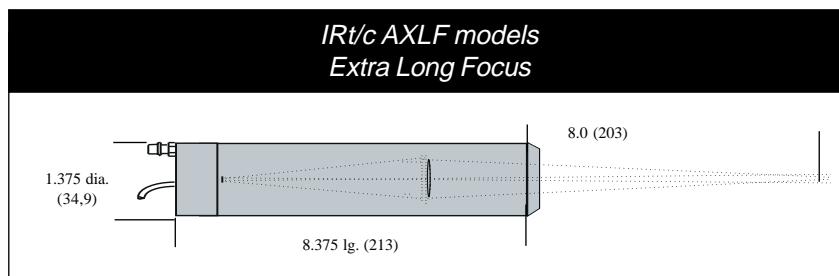
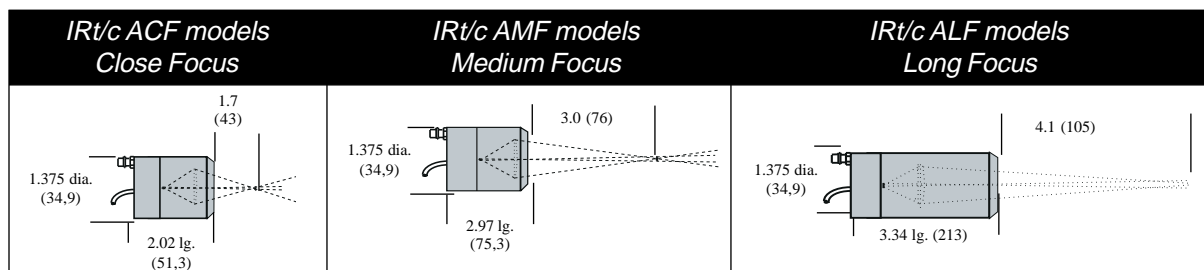

Ordering information: (Model) - (Thermocouple Type) - (HiE or LoE)

Use the Selection Table. Select the model for (1) temperature range (2) spot size, and (3) target surface material (nonmetal or metal, uncoated). Then finally, (4) select the thermocouple type (J,K, R or S).

Example: **IRt/c.10A -K- HiE**

Adjustable IRt/c Options

Adjustable IRt/c models are also available, Pre-Calibrated, from Exergen with NIST traceability for quick multiple same sensor installations for factory automation and OEMs. Also, millivolt signal output curves and mv tables are available for all sensor models for special calibrations.

Adjustable Models Selection Table

Model	T/C Types	Temperature Range		Spot Size	Target Surface
		°F	°C		
.10A-HiE	J, K	-50 to 2500	-45 to 1370	Distance ÷ 10	Nonmetal
.10A-LoE	J, K	500 to 2500	260 to 1370	Distance ÷ 10	Metal
.20A-HiE	J, K	500 to 3000	260 to 1650	Distance ÷ 20	Nonmetal
.20A-LoE	J, K	1000 to 3500	540 to 1930	Distance ÷ 20	Metal
.100A-HiE	R, S	1000 to 5000	540 to 2760	Distance ÷ 100	Nonmetal
.100A-LoE	R, S	1500 to 5000	820 to 2760	Distance ÷ 100	Metal
.2ACF-HiE	J, K	500 to 2500	260 to 1370	2.9 mm	Nonmetal
.2ACF-LoE	J, K	1000 to 2500	540 to 1370	2.9 mm	Metal
.2/15ACF-HiE	J, K	0 to 2500	-18 to 1370	2.9 x 8.7 mm	Nonmetal
.2/15ACF-LoE	J, K	500 to 2500	260 to 1370	2.9 x 8.7 mm	Metal
.3AMF-Hi E	J, K	500 to 2500	260 to 1370	3.7 mm	Nonmetal
.3AMF-LoE	J, K	1100 to 2500	590 to 1370	3.7 mm	Metal
.4ACF-HiE	J, K	0 to 2500	-18 to 1370	5.0 mm	Nonmetal
.4ACF-LoE	J, K	600 to 2500	320 to 1370	5.0 mm	Metal
.8ACF-LoE	J, K	300 to 2500	150 to 1370	8.5 mm	Metal
.2/18AMF-HiE	J, K	0 to 2500	-18 to 1370	4.5 x 12.8 mm	Nonmetal
.2/18AMF-LoE	J, K	600 to 2500	320 to 1370	4.5 x 12.8 mm	Metal
.6AMF-HiE	J, K	0 to 2500	-18 to 1370	6.5 mm	Nonmetal
.6AMF-LoE	J, K	700 to 2500	370 to 1370	6.5 mm	Metal
.12AMF-LoE	J, K	400 to 2500	200 to 1370	11.1 mm	Metal
.2/15ALF-HiE	J, K	700 to 3000	370 to 1650	3.0 x 7.2 mm	Nonmetal
.2/15ALF-LoE	J, K	1200 to 3500	650 to 1930	3.0 x 7.2 mm	Metal
.4ALF-HiE	J, K	700 to 3000	370 to 1650	4 mm	Nonmetal
.4ALF-LoE	J, K	1300 to 3500	700 to 1930	4 mm	Metal
.7ALF-HiE	J, K	300 to 3000	150 to 1650	7.2 mm	Nonmetal
.7ALF-LoE	J, K	900 to 3500	480 to 1930	7.2 mm	Metal
.2AXLF-HiE	R, S	1100 to 3500	590 to 1930	1.8 mm	Nonmetal
.2AXLF-LoE	R, S	2200 to 3500	1200 to 1930	1.8 mm	Metal
.4AXLF-HiE	R, S	900 to 3500	480 to 1930	4.8 mm	Nonmetal
.4AXLF-LoE	R, S	1700 to 3500	930 to 1930	4.8 mm	Metal

The part number of an IRt/c sensor is made up of three parts:

Model Number - Thermocouple Type - Temperature Range,

for pre-calibrated sensors
e.g. IRt/c.3X - J - 440F1220C

Model Number - Thermocouple Type - HiE or LoE,

for adjustable models
e.g. IRt/c.20A - K - LoE

To select a model for an application, answer the following five points in order. You should then be in a position to select the optimum sensor.

1. Type of Controller /Transmitter / Input

Most sensors are available in J, K, E or T types. The thermocouple type should be the same as the readout/controller input type.

2. Target Material

Virtually all non-metal surfaces are good emitters and work well with IRt/c sensors (Tech Note #31). If a target is to be viewed and it cannot be coated or an uncoated metal masked, a LoE model must be selected (Tech Note #21).

3. Target Temperature

Exergen offers 8 pre-calibrated temperature ranges for convenience (Tech Note #49). The sensors can be used outside their calibrated ranges, up to the temperature limit;with stated repeatability:

550°F limit: IRt/c.01 and IRt/c.03
1200°F limit: IRt/c, IRt/c.1X, IRt/c.3X,
IRt/c.5 and IRt/c.10

4. Target Size and Distance Between Sensor and Target

The target should completely fill the field of view (Tech Note #55). As an example, the IRt/c.3X has a 3:1 field of view, this means that at a distance of 24" from the target the sensor will view a 8" diameter spot (spot size = distance ÷ 3). All of the IRt/c sensors have a minimum spot size (this minimum spot size varies with model type). It is not recommended that a sensor be used with a target smaller than the minimum spot size. Based on the minimum spot size:

For a target <0.3" (8mm),
select a focused unit

Additional Selection Explanations

For a target 0.3-0.8" (8-20mm),
select IRt/c, IRt/c.01, IRt/c.03,
IRt/c.1X or IRt/c.3X

For a target >0.8" (20mm),
select any sensor.

5. Ambient Temperature and Environment

The IRt/c.01 and IRt/c.03 can be used in ambient temperatures up to 160°F (70°C). All of the other sensors can be used in ambient temperatures up to 212°F (100°C) without any external cooling.

Above 212°F the IRt/c can be used with the CJK-1 cooling jacket and the IRt/c.3X can be used with the CJK-2 cooling jacket (see accessories). The IRt/c.5, IRt/c.10 and all of the adjustable sensors have a built in air purge that can be used to cool to ambient temperatures up to 450°F (230°C). If the environment where the sensor is placed is prone to be dusty or otherwise dirty, it is good practice to select a sensor with an air purge.

If linearization software can be employed in the readout device, HiE and LoE models can be supplied in a pre-calibrated form (see Tech Note #96). This allows for the convenience of a pre-calibrated range and security from accidental sensor adjustment after installation.

Example

For the following situation:

- 1) K-type readout
- 2) Target Material; black conveyer belt
- 3) Target temperature; 300°F (150°C)
- 4) Target size and distance; belt 24" (61 cm) wide, sensor 1.5" (3.8 cm) away.
- 5) Ambient temperature and environment; ambient 80°F, (27°C) oil vapors present

For this application the best sensor to select would be an IRt/c.3X-K-280°F/140°C. The sensor type must be a K-type to match the readout. The target material is highly emissive. The temperature range is converted easily by this sensor and the 280°F/140°C calibration range from the temperature selection guide is the best one for 300°F (150°C). The IRt/c.3X has a 3:1 field of view, at 1.5" (3.8 cm) distance it will have a spot size of 0.5" (1.3 cm); this sensor has a built-in air purge which would be useful to keep the lens clean from oil vapor.



IRt/c.01HH-K-RF Infrared Probe

For Refrigerated Foods Temperature Inspection

Based on the IRt/c.01 family of models, the **IRt/c.01HH-K-RF** is an accurate but inexpensive infrared probe designed to be used with all common type K thermocouple meters. It provides the user with the following advantages over contact food probes:

- Non-contact, sanitary, no cross-contamination.
- Reduces inspection costs.
- Valuable food is not discarded.
- Much faster measurement results in less inspector time.
- Much higher repeatability than contact devices for surface temperature.
- No contact error.
- No heat-sinking error, both internal and external.
- Rugged and durable, and does not require regular replacement due to wear.
- Establishes true, repeatable standards for food temperature measurement.
- Plugs directly into t/c handheld meters, data acquisition systems, etc.

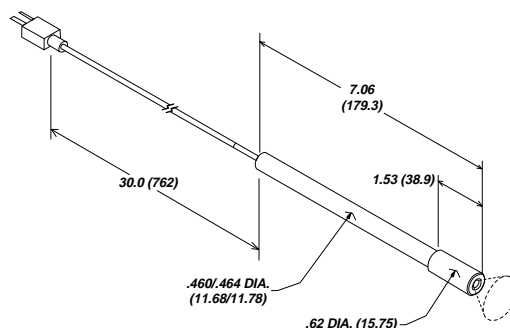
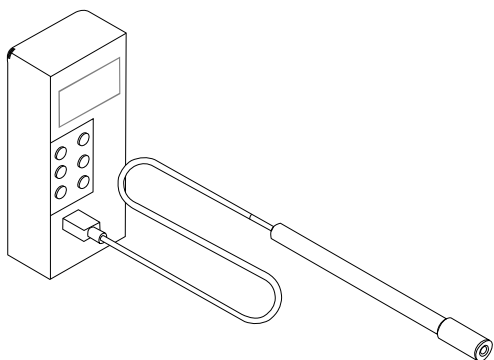

Food Temperature Range	0 to 80°F (-18 to 27°C)
Field-of-View	1:1 approximately
Speed of Response	0.1 second approx.
Construction	ABS plastic housing and handle, hermetically sealed, immersible for cleaning.
Cable	30 in. (0.76 m) type K with molded plug connector

IRt/c.01HH Infrared Probe

**Plugs Into Any Portable
Thermocouple Meter for Low Cost
Non-contact Hand-held Temperature
Inspection System**



Based on the IRt/c.01 family of models, the **IRt/c.01HH is an accurate but inexpensive infrared probe designed to be used with all common type K thermocouple meters. It provides the user with the following advantages over contact probes:**

- Non-contact, sanitary, no cross-contamination.
- Reduces inspection costs, due to preservation of test sample and much higher speeds.
- Much higher repeatability than contact devices for surface temperature.
- No contact error.
- No heat-sinking error, both internal and external.
- Rugged and durable, and does not require regular replacement due to wear.

