



The swivelling crane control unit KST 5 is ergonomically designed and provides a high degree of comfort.

The standard design includes following:

Equipment boxes: Sheet steel. The top panel of the equipment boxes with the devices can be raised and locked in position. The terminal strip is easily accessible via an opening on the inside that can be closed with a lockable cover.

Seat: Comfortable spring mounted seat KFS 9, with an oilhydraulic vibration absorption system, weight adjustment and air-permeable artificial-Leather or textil material.

Adjusting possibilities: Seat horizontally and vertically, Inclination of cushion, backrest and armrest also adjustable. Weight setting for optimum spring suspension.

Cross-member: Steel section, top of which can be raised to lay cabling. The seat can be tilted backwards so that the cable duct in the crossmember is accessible.

Swivel base: zero-end-float spring-loaded bearing  
Rotational movement 180° right, 90° left, stopped by friction-brake.

Surface treatment: Anti-corrosion primer, top coat: 2 coats of epoxy-resin paint, standard colour RAL 7032 pebble-gray. All non-painted metal parts are electrogalvanized and chromed.

Permissible ambient temperature                      Operation -40° C to + 60° C  
Storage -50° C to + 80° C

Climate resistance  
Damp heat constant                                      DIN IEC 68 part 2-3  
Damp heat cyclic    DIN IEC 68 part 2-30  
Degree of protection                                    IP 54 IEC 529 DIN 40050

Description data look catalog 5/003/004

Pos.		Type	Weight kg	Price EURO
1	Crane control unit standard design	Equipment boxes 200 x 580 mm	KST 51	84
2	Crane control unit standard design	Equipment boxes 270 x 580 mm	KST 52	88
3				
4	Crane control unit standard design	Equipment boxes 320 x 580 mm	KST 54	92
5	Crane control unit standard design	Equipment boxes special dimensions	KST 5x	enquiry
6	Headrest for driver's seat KFS 9			
7	additional variations for driver's seat KFS 9 look catalog 2/140			
8	Driver's seat KFS 10 look catalog 2/142	KFS 10		
9	Monitor mounting support left or right T 478		10	
10	Foot rest mounted onto swivel base adjustable ± 15 mm		8	
11				
12	Manual adjustment of equipment boxes horizontal adjustable ± 75 mm			
13	Plate for horizontal manual adjustment of control unit adjustable ± 250 mm		95	
14	Manual adjustment of control unit vertical (gas loaded spring) adjustable 80 mm		25	
15				
16				
17				
18	Motorized adjustment of control unit swivelling (drive 24 V DC seat height + 30 mm)		8	
19				
20	Multi-axis controller	look catalog 1/100		
21	Single-axis controller	look catalog 1/200		
22	Double handle controller	look catalog 1/160		
23	Control-switch	look catalog 1/220		
24	Command and indicating devices	look catalog 1/360		
30	Terminal block 4 mm <sup>2</sup> without wiring each terminal		KL	
31	Terminal block 4 mm <sup>2</sup> with wiring wire 1,5 mm <sup>2</sup> each terminal		KL	
32	External wiring single wire highly flexible 1,5 mm <sup>2</sup> 5 metre long			
33	Additional or subtract price each metre			
40	Special painted			
41	Indicating labels not engraved with 2 or 4 arrows			
42	Engraved each 10 characters			



**GESSMANN**

Elektro-Trading sp. z o.o.  
tel. (032) 734-55-72  
et@elektro-trading.com.pl

**Crane control unit KST 5 swivelling  
manual adjustment**

2/051  
2002

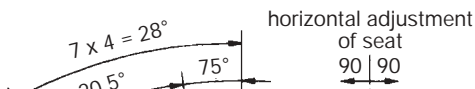
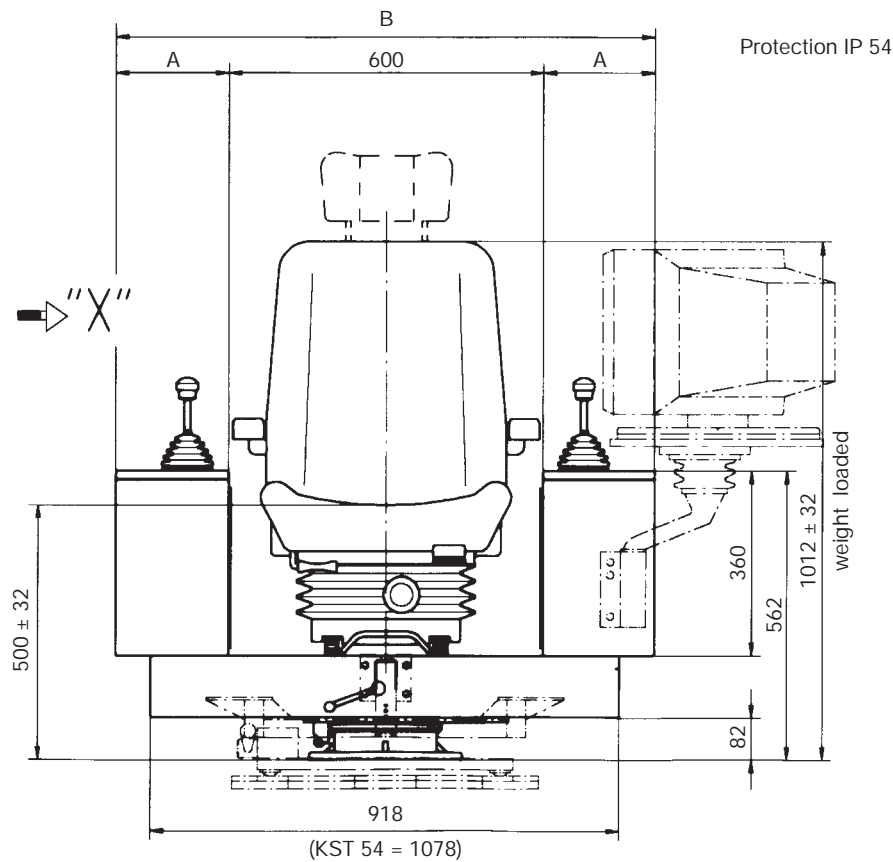

Type	Dimension A	Dimension B	Dimension C
KST 51	200	1000	580
KST 52	270	1140	640
KST 54	320	1240	690

view „X“

