



**GESSMANN**

Elektro-Trading sp. z o.o.  
tel. (032) 734-55-72  
et@elektro-trading.com.pl

## Crane control unit KST 15 swivelling manual and/or motorized adjustment

2/102

2002



The swivelling crane control unit KST 15 is ergonomically designed and provides a high degree of comfort.

The standard design includes following:

**Equipment boxes:** Sheet steel. The top panel of the equipment box with the devices can be raised and locked in position. The terminal strip is easily accessible via an opening on the inside that can be closed with a lockable cover. The external wiring is run through duct from the equipment boxes in the cross-member.

**Seat:** Comfortable spring mounted seat KFS 10, with a pneumatic vibration absorption system by compressor 24 V DC, weight adjustment and airpermeable artificial-Leather or textil material.

**Manual adjustments:** Seat horizontally and vertically, Inclination of cushion, backrest and armrest also adjustable, weight setting for optimum spring suspension.

**Motorized adjustments:** Seat with equipment-boxes vertical (inclinations adjustments forward/backward), Seat with equipment-boxes horizontal. Selector switches for motorized-drives are in the equipment box. Motor 12 V DC ca. 30 ampere.

**Cross-member:** Steel section, top of which can be raised to lay cabling. The seat with the boxes can be tilted forwards so that the cable duct in the cross-member is accessible.

**Swivel base:** zero-end-float spring-loaded bearing. Rotational movement 180° right, 90° left, stopped by friction-brake.

**Surface treatment:** Anti-corrosion primer, top coat: 2 coats of epoxy-resin paint, standard colour RAL 7032 pebble-gray. All non-painted metal parts are electrogalvanized and chromed.

Description data look catalog 5/003/004

Permissible ambient temperature	Operation -40° C to + 60° C Storage -50° C to + 80° C
Climate resistance	
Damp heat constant	DIN IEC 68 part 2-3
Damp heat cyclic	DIN IEC 68 part 2-30
Degree of protection	IP 54 IEC 529 DIN 40050

Pos.		Type	Weight kg	Price EURO
1	Crane control unit standard design	Equipment boxes 200 x 580 mm	KST 151	236
2	Crane control unit standard design	Equipment boxes 270 x 580 mm	KST 152	240
3				
4	Crane control unit standard design	Equipment boxes 320 x 580 mm	KST 154	244
5	Crane control unit standard design	Equipment boxes special dimensions	KST 15x	enquiry
6	Headrest for driver's seat KFS 10			
7	additional variations for driver's seat KFS 10 look catalog 2/142			
8	Driver's seat KFS 9 look catalog 2/140	KFS 9		
9	Monitor mounting support left or right		10	
10	Foot rest mounted onto swivel base adjustable ± 15 mm		8	
11				
12				
13	Plate for horizontal manual adjustment of control unit adjustable ± 250 mm		95	
14				
15	Motorized adjustment of equipment boxes vertical adjustable ± 25 mm			
16	Motorized adjustment of equipment boxes horizontal adjustable ± 40 mm			
17				
18	Motorized adjustment of control unit swivelling (drive 24 V DC, seat height + 30 mm)		18	
19				
20	Multi-axis controller look catalog 1/100			
21	Single-axis controller look catalog 1/200			
22	Double handle controller look catalog 1/160			
23	Control-switch look catalog 1/220			
24	Command and indicating devices look catalog 1/360			
30	Terminal block 4 mm <sup>2</sup> without wiring each terminal	KL		
31	Terminal block 4 mm <sup>2</sup> with wiring wire 1,5 mm <sup>2</sup> each terminal	KL		
32	External wiring single wire highly flexible 1,5 mm <sup>2</sup> 5 metre long			
33	Additional or subtract price each metre			
40	Special painted			
41	Indicating labels not engraved with 2 or 4 arrows			
42	Engraved each 10 characters			

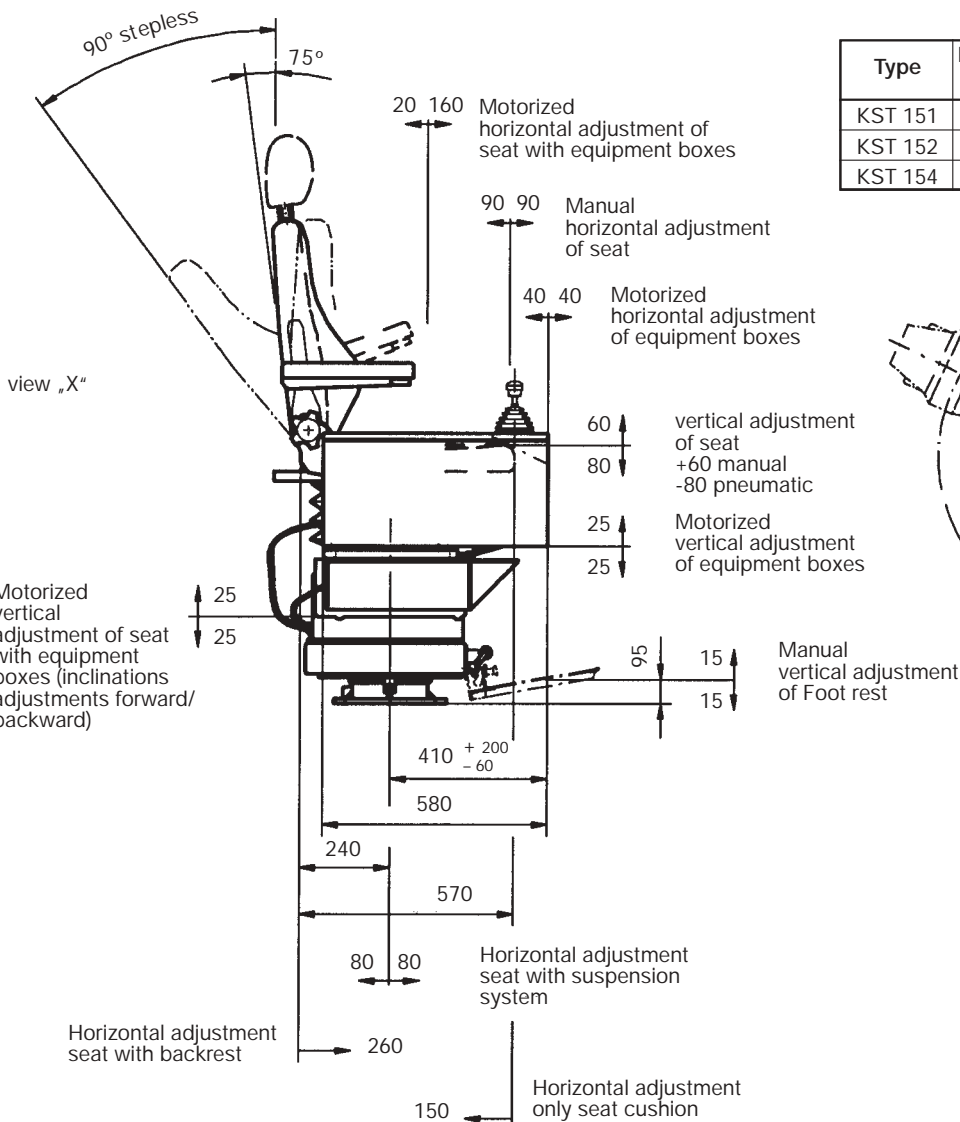
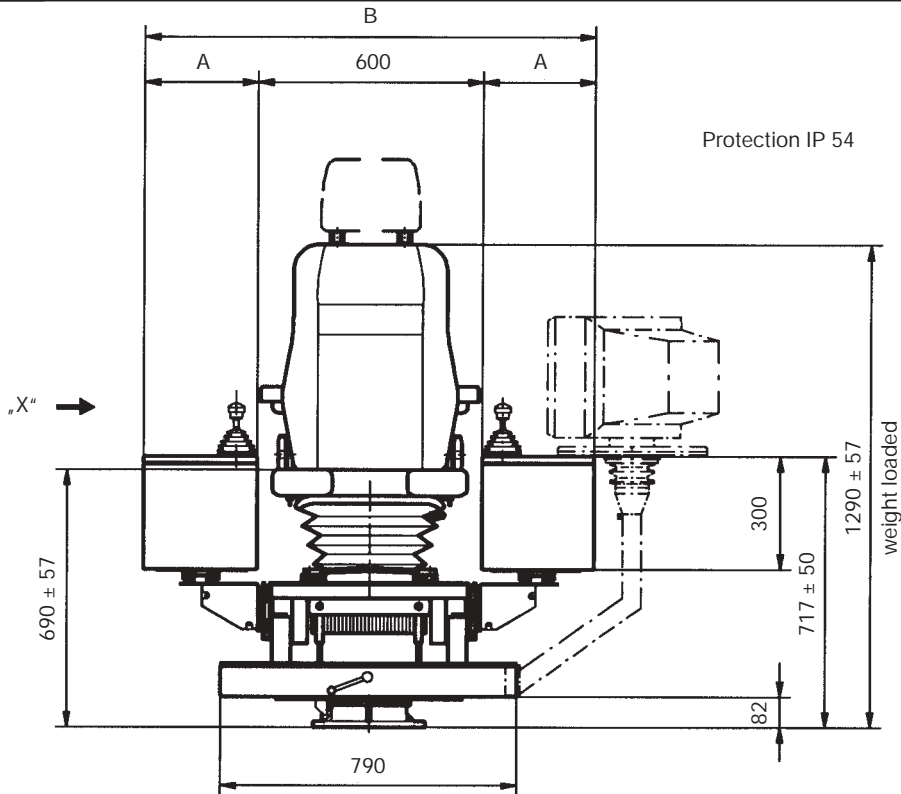

Type	Dimension A	Dimension B	Dimension C
KST 151	200	1000	800
KST 152	270	1140	845
KST 154	320	1240	880

